

# SITE ANALYSIS

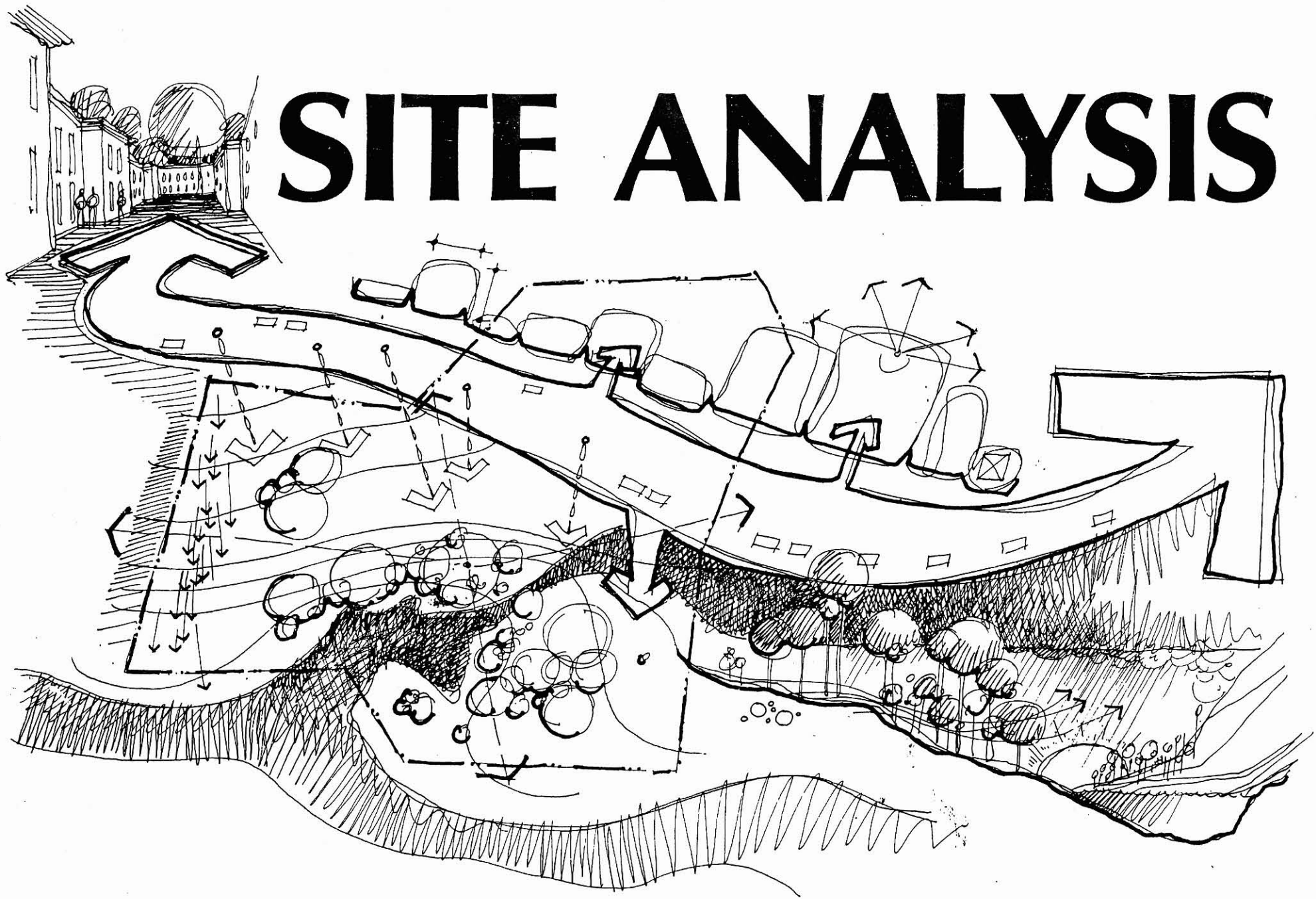

EDWARD T. WHITE

# **SITE** DIAGRAMMING INFORMATION FOR ARCHITECTURAL DESIGN **ANALYSIS**

**EDWARD T. WHITE**

PROFESSOR OF ARCHITECTURE • FLORIDA A&M UNIVERSITY



**ARCHITECTURAL MEDIA**

Site Analysis: Diagramming  
Information for Architectural Design  
Copyright © 1983 by Edward T. White  
All rights reserved  
Printed in the United States of America  
ISBN 1-928643-04-3

### **Architectural Media Monograph Series**

- Project Programming: A Growing Architectural Service
- Teaching Architectural Programming
- Interviews With Architects About Facility Programming
- Design Briefing in England
- Facility Programming and the Corporate Architect
- Programming, Post - Occupancy Evaluation and the Financial Success of the Architect
- Learning Decision - Making for the Building Process
- Building Evaluation in Professional Practice
- Post - Occupancy Evaluation and the Corporate Architect
- The Value of Post - Occupancy Evaluation to the Architect in Government
- Post - Occupancy Evaluation from the Client's Perspective

### **Architectural Media Books**

- A Graphic Vocabulary for Architectural Presentation
- Introduction to Architectural Programming
- Ordering Systems: An Introduction to Architectural Design
- Concept Source Book: A Vocabulary of Architectural Design
- Presentation Strategies in Architecture
- Site Analysis: Diagramming information for Architectural Design
- Space Adjacency Analysis: Diagramming Information for Architectural Design
- Images of Italy
- Path • Portal • Place
- Building Meaning

**Architectural Media Ltd.**  
**P.O. Box 10588**  
**Tallahassee, Florida 32302**  
**850 222-1223**  
**FAX 850 561-0021**

PREFACE	1
<b>DEFINITIONS, ISSUES AND DESIGN IMPLICATIONS</b>	<b>5</b>
OVERVIEW	6
SITES AS ACTIVE NETWORKS	8
CONSEQUENCE TRIANGLE	9
BEING THOROUGH	11
KINDS OF INFORMATION	16
LOCATION	18
NEIGHBORHOOD CONTEXT	18
SIZE AND ZONING	18
LEGAL	18
NATURAL PHYSICAL FEATURES	19
MAN MADE FEATURES	19
CIRCULATION	19
UTILITIES	19
SENSORY	20
HUMAN AND CULTURAL	20
CLIMATE	20
IMPLICATIONS FOR DESIGN	21

<b>DIAGRAMMING SITE INFORMATION</b>	<b>25</b>
OVERVIEW	26
PROCESS	28
ISSUE IDENTIFICATION	28
COLLECTING THE DATA	35
MAKING THE DIAGRAMS	40
DIAGRAMMATIC FRAMEWORK	40
REFERENT DRAWINGS	42
DIAGRAMMATIC FORMS	43
SITE ANALYSIS CASE STUDY	44
REFINEMENT AND SIMPLIFICATION	108
GRAPHIC EMPHASIS AND CLARITY	118
TITLES, LABELS AND NOTES	119
ORGANIZING THE DIAGRAMS	121
SUBJECT CATEGORY	121
QUANTITATIVE—QUALITATIVE	122
GENERAL—PARTICULAR	122
RELATIVE IMPORTANCE	122
SEQUENCE OF USE	123
INTERDEPENDENCY	123
INTERPRETING THE DIAGRAMS	126
WHEN TO USE CONTEXTUAL ANALYSIS	141
OTHER CONTEXTUAL ANALYSIS FORMS	142
PHOTOGRAPHS	142
MODELS	143
MOVIES	144
TRANSPARENT OVERLAYS	145
INTERIOR SPACE ANALYSIS	145

# CONTENTS

# PREFACE

We designers are often more comfortable and skilled at drawing plans, elevations, sections and perspectives than at diagramming project needs, issues and requirements.

We sometimes seem overly anxious to draw the architectural answers to ill-defined project questions and reluctant to invest in graphic techniques that help us better understand the project needs and that stimulate responsive and creative design concepts.

We need to balance our skills at drawing design solutions with our skills at drawing and visualizing the problems and requirements.

This book is the first of a planned series about diagramming in architectural design. The theme of the series is visualizing information for design in the dual sense of converting the information into graphic images and seeing or understanding the information better. The central thesis is that our ability to draw needs, requirements and early design concepts is just as important as our ability to draw final building design solutions and that, in fact, our diagramming skills profoundly influence the quality of our building designs.

There are several reasons why it is helpful for us to visualize design information when planning buildings:

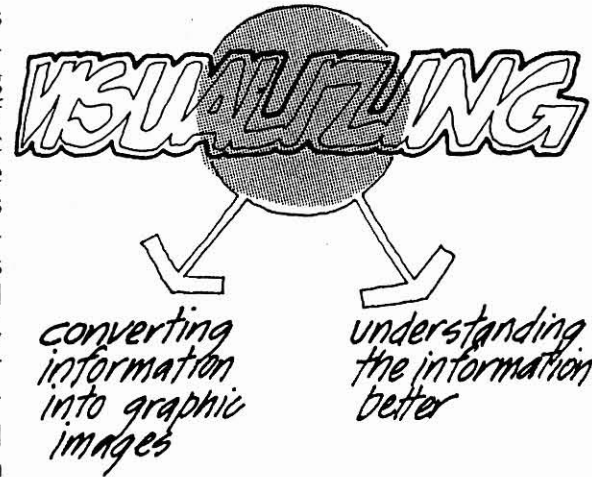
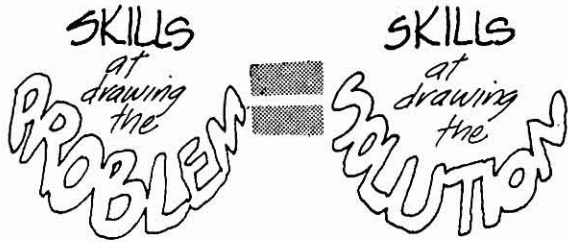
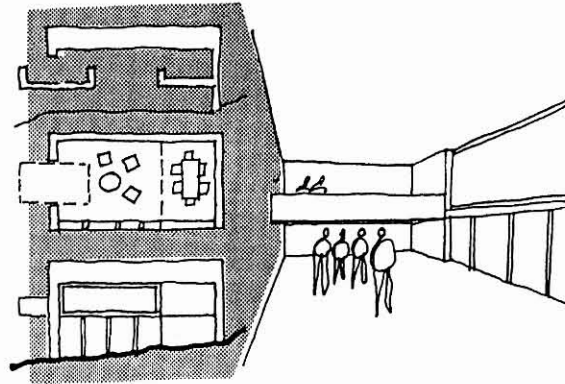

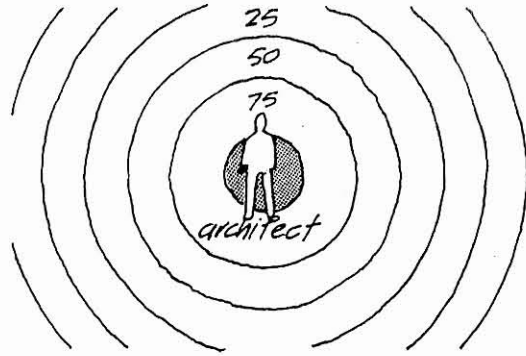

**Accountability.** As designers, we are being held responsible for the success of more and more aspects of the building delivery process and of the performance of the buildings we design. At the same time, the criteria for successful buildings are becoming more defined and the building evaluation processes more systematic and rigorous. New facts are being produced by the building research community each year which multiply our professional, legal and moral obligations and responsibilities in projects. Diagramming is a tool which can assist us in coping with information overload and in more thoroughly addressing the project requirements in design.

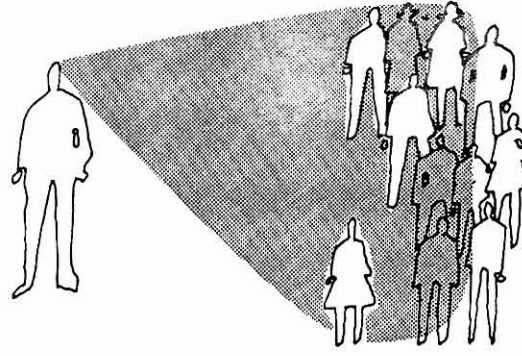

**Communications.** Clients of architectural projects are becoming increasingly multipersonal (boards, committees, community involvement) and more demanding in terms of their participation in design decisions. Complex clients often mean complex interpersonal relationships, conflicts and difficulties in obtaining consensus and timely decisions. These situations require strong project organization, clear procedures and effective communication techniques to facilitate thoughtful, well-informed decisions. We must have solid defensible reasons for our design recommendations that are rooted in the needs of our clients. We must render the decision processes in design more transparent so that our clients can understand where we are, where we've been and where we're going. We must be better documented in both the analysis of the problems and in our generation of the solutions. It is important for us to leave decision tracks that can be retraced and to be able to explain how we arrived at particular design proposals. Diagramming is an effective means of increasing the quality of communication in our building planning processes.

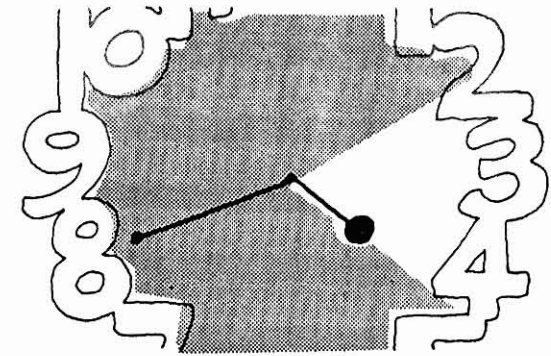

**Efficiency.** We are constantly faced with severe time pressures to expedite the completion of projects to meet client deadlines and to finish work within internal (design office), budget and time constraints. Very few design offices can afford to plan projects in a leisurely, passive manner—that is, to wait until good design ideas “happen along.” We must be able to make ideas happen, to design assertively and to control idea-getting processes rather than allowing these processes to control us. We should have tools which can help us to cause design solutions to occur in a relatively short time. This need for techniques extends beyond problem analysis and conceptualization into the synthesis, testing and refinement of design solutions. Diagramming is an excellent tool for getting started in our design thinking, for taking control of the planning process and for getting unstuck when we hit snags.

Diagramming is an important aspect of our design language with which we produce our design solutions. Mastery of that language is fundamental to attaining competence in the design profession. Much of the attention in the area of design graphics has been focused on techniques for drawing our final building designs. We need to begin to codify those predesign and early design graphic techniques that help us to surround the problem, define it, crack it, enter it, and explore alternative architectural responses to it.

Diagramming is a way to get close to the problem, to engage it, to absorb it, to restate it in our own terms and to render it second nature so that we can attend to the selection and integration of potential solutions.

Ideally, the profile of the design solution should mirror the profile of the programmatic requirements and conditions. Diagramming is useful in constructing the problem profile so that it may serve as a beacon toward which to manage the design solution.

Investing in diagramming often leads us to the discovery of design ideas that otherwise wouldn't have occurred to us. It helps us to build our vocabulary of design solutions for use in future projects by expressing solution types in storable and retrievable (memorable) form. Diagramming assists us in bridging between the problem as expressed in verbal terms and the solution as expressed in physical/architectural terms. Through diagramming we decrease the likelihood of losing something in the

translation from problem to solution. Diagramming can facilitate the discovery of key problem issues and can clarify, summarize, amplify, and test verbage. It is a way of simplifying and collapsing project issues into a manageable number and of transforming those issues into more meaningful and evocative form for design. Diagrams can serve as efficient reminders (programmatic shorthand) about complex issues during design that would require pages to explain in writing. The entertainment value of diagrams helps to make programmatic information less tedious and intimidating and more approachable.

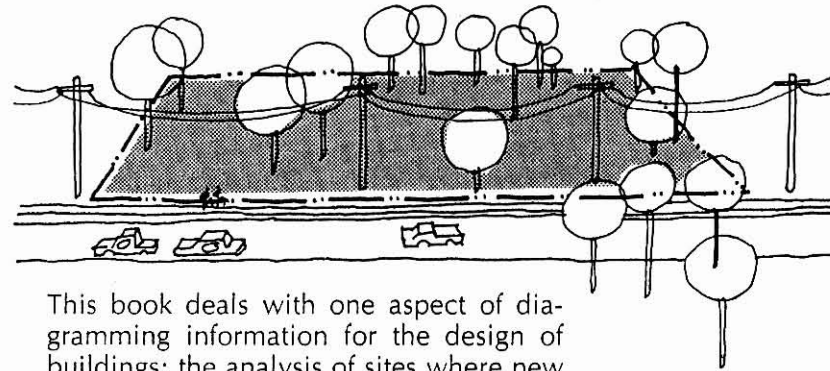
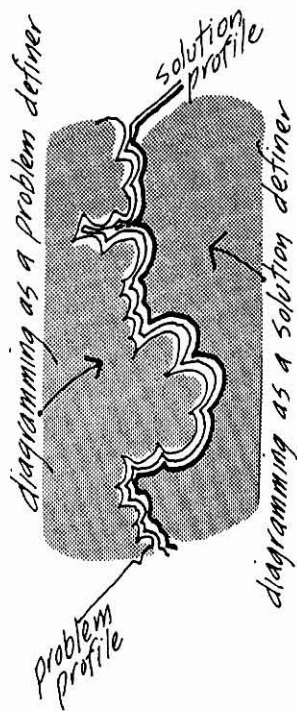

This book deals with one aspect of diagramming information for the design of buildings: the analysis of sites where new buildings will be built.

**Contextual analysis, that is, the study of project property, is a vital prelude to making sound decisions about optimum site utilization, best on site arrangements of clients' interior and exterior activities and spaces, and most effective ways to respect and capitalize upon site assets.**



**DEFINITIONS,  
ISSUES AND  
DESIGN  
IMPLICATIONS**

# OVERVIEW

Contextual analysis is a predesign research activity which focuses on the existing, imminent and potential conditions on and around a project site. It is, in a sense, an inventory of all the pressures, forces and situations and their interactions at the property where our project will be built.

**The major role of contextual analysis in design is that of informing us about our site prior to beginning our design concepts so that our early thinking about our building can incorporate meaningful responses to external conditions.**

Typical site issues addressed in a contextual analysis are site location, size, shape, contours, drainage patterns, zoning and setbacks, utilities, significant on site features (buildings, trees, etc.), surrounding traffic, neighborhood patterns, views to and from the site and climate. As designers we need to know something about these issues in order to design a successful building that not only meets its internal responsibilities (functions) but that also relates well to its external environment. Since our building will exist for several years, our contextual analysis should attempt to deal with potential future conditions as well as the ones we can observe on the site today. Some of the typical issues in this regard are changing zoning patterns around our site, shifts in the designation of major and minor streets, changing cultural patterns in the surrounding neighborhood and the construction of significant projects nearby that impact on our site.

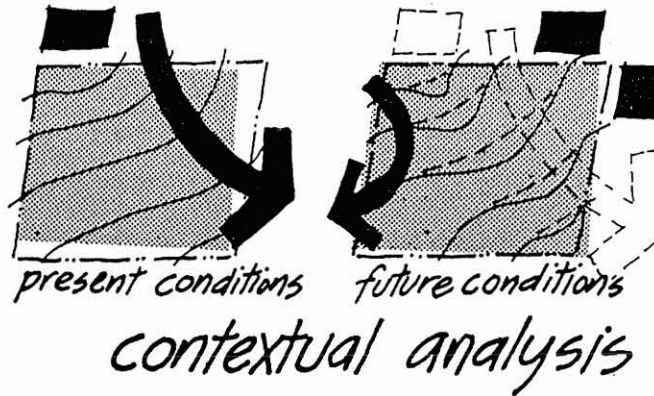
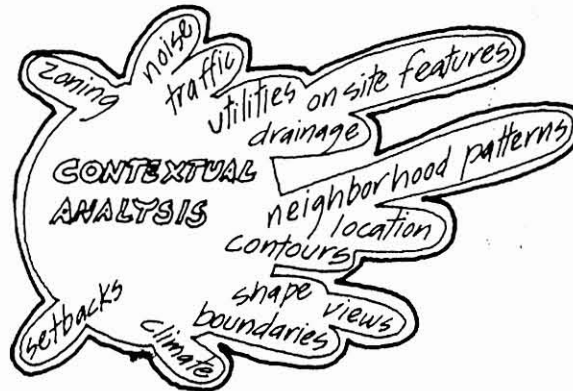
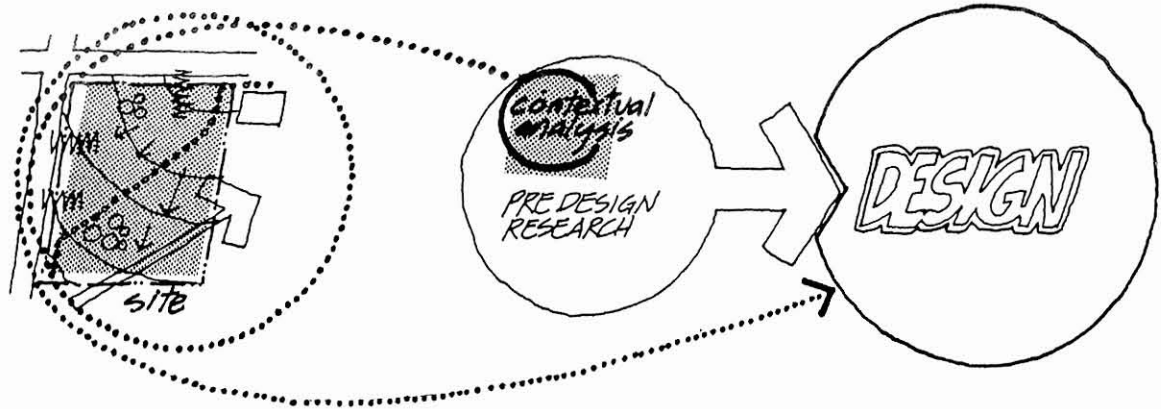

Just as a single word or phrase is best understood when we know something about its surrounding verbal context so also should we be aware of the contextual situation where our building will be sited.

**Context is defined in the dictionary as the "whole situation, background or environment relevant to some event or product." The derivation of the word means to "weave together."**

The spirit of this meaning tells us something as designers regarding the need to "weave" our designs into the existing fabric of site conditions, pressures, problems and opportunities. We must strive for a sense of fit between the newcomer to the site (our building) and the site itself. The notion of "fit" does not necessarily imply subordination of our building to site conditions. We may choose to be in sympathy with some site conditions where we attempt to save, reinforce, amplify and improve on what we find on the site. We may also identify certain site conditions which we want to deliberately alter, eliminate, cover up, disguise or reform. "Weaving" as a concept applied to the placement of buildings on sites will always include some alteration of the existing conditions. What is important is that we make these decisions deliberately and thoughtfully so that the effects of our building on the site are not accidental. Whether attempting to go "with" the site or to "contrast" the site, our early thinking is pivotal in terms of producing a successful project.

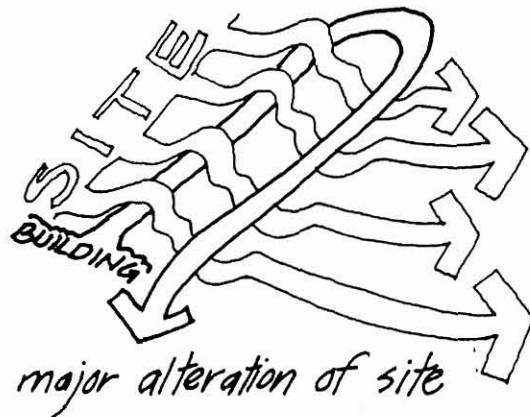
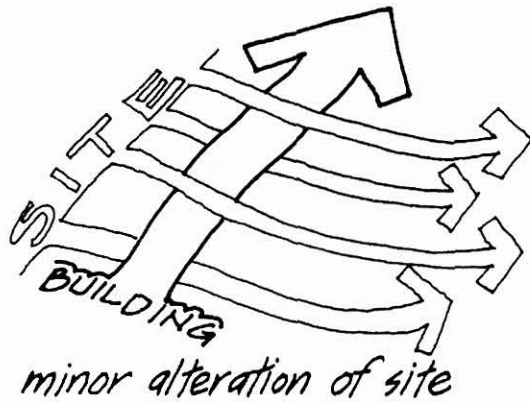
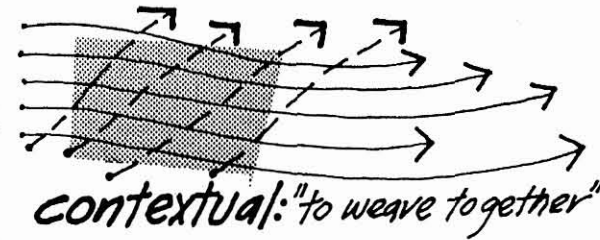
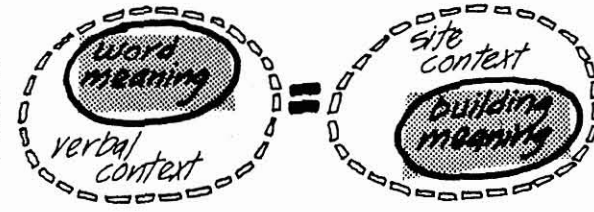

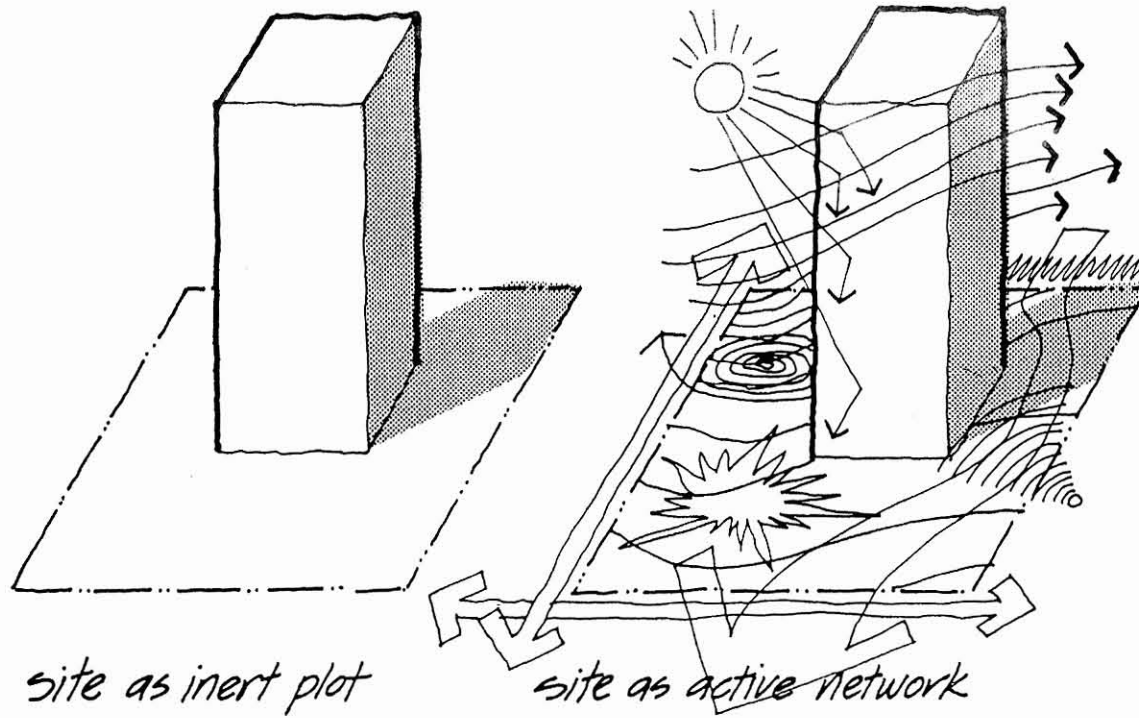

*site as inert plot*

*site as active network*

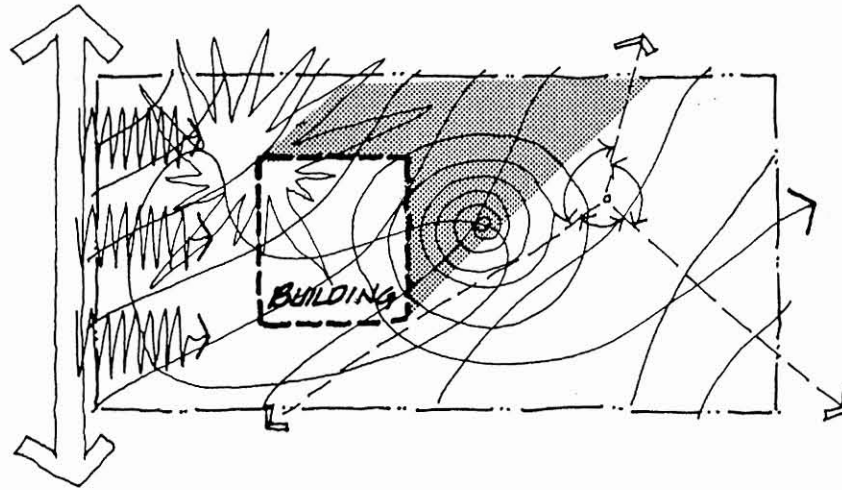

## SITES AS ACTIVE NETWORKS

Sometimes as designers we may be tempted to think of our project site as an inert, passive situation. We may consider it as simply a piece of ground where our building will sit.

**We should always remember that a site is never inert but is an ongoing set of very active networks that are intertwined in complex relationships.**

Shadow patterns move across our site in a particular way. Children may use our site as a shortcut to school. Our site may be used as an informal playground by neighborhood children. There is a traffic pulse that ebbs and flows through and around the site over the course of a day. People may look across our site from their homes to views beyond. The contours may carefully route water to a site edge where it does no damage to neighbors. The corner may be used for a bus stop. These are a few of the situations that make any site active. This kinetic view of site should sensitize us to the importance of the task of siting our building. We are about to place our building within this active network. It seems reasonable to assume that if we are to integrate our design gracefully into this network without destroying its positive aspects, then we must first make ourselves aware of the nature of the network through contextual analysis.

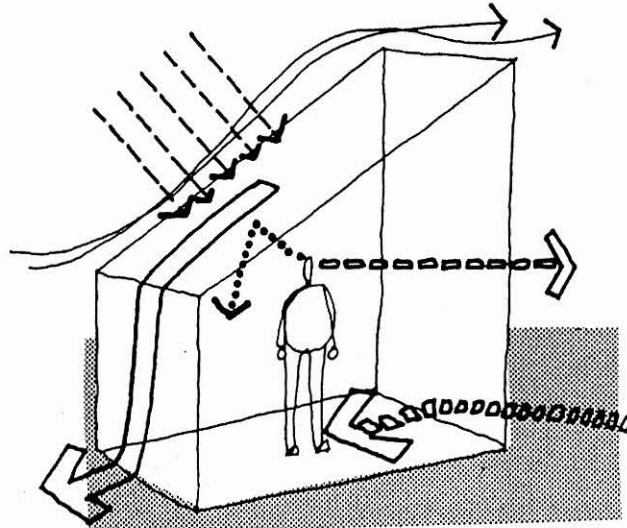

## CONSEQUENCE TRIANGLE

The "consequence triangle" is a convenient model for understanding the network of contextual causes and effects and how they relate to other aspects and issues of our project.

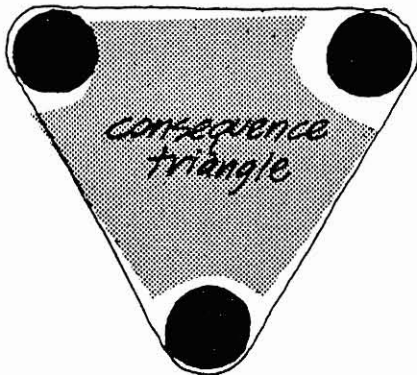

The consequence triangle focuses on the simulation of the completed and occupied building and is based on the hypothesis that it is not the design or the building itself which is our ultimate responsibility as designers but the prediction and delivery of a set of consequences or effects that have been deemed positive and possible.

There are three "actors" in the consequence triangle: the building, the users and the context. The building includes all the interior and exterior physical manifestations of our design such as the walls, floors, ceilings, structure, mechanical, furniture, lighting, color, landscaping, paving, doors, windows, hardware and accessories. The users include all those people who own the

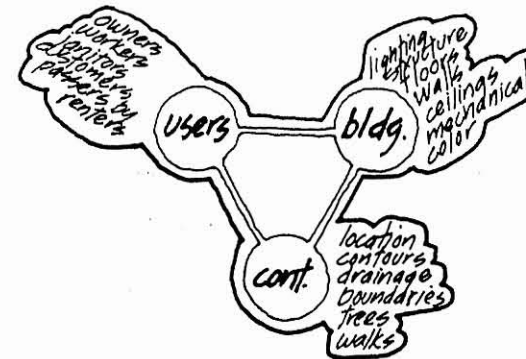

building, work in the building, maintain the building, are clients, patrons or customers in the building, service the building, live near the building or simply pass by the building. The context includes all the conditions, situations, forces and pressures that constituted the existing site prior to the construction of the building.

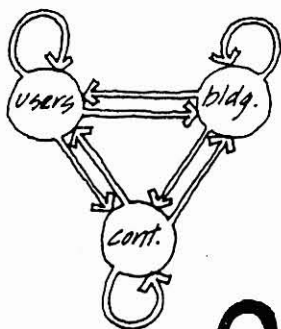

If we set these three protagonists at the corners of a triangle and draw lines representing impacts from each of them to all the others and from each of them to themselves, we have diagrammed the essential messages of the consequence triangle. The elements of the building affect not only each other but also elements in the context and users. In terms of building impact on itself, the air conditioning system causes changes in material and furniture because of temperature and humidity differential. Fenestration causes changes in material, lighting and furniture because of the admittance of sunlight. Furniture location causes changes in the flooring material due to placement in the space. The consequences caused by the building on the users may involve environmental effects on attitude, productivity, efficiency, sense of worth and well-being, staff turnover, level of learning, sales volume and other aspects of human behavior. The building also creates consequences within the context. These may include alteration of wind patterns, contours and drainage patterns, surface absorption of rainfall, existing foliage, shadow patterns, sunlight reflection off windows and sound reflections off building surfaces.

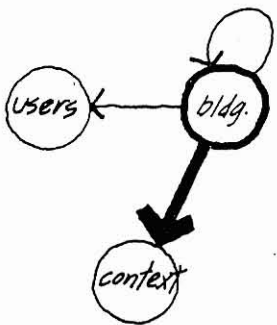
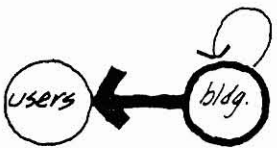

All of the effects or consequence issues mentioned here only deal with impacts caused by our building on itself, users and context. To complete the model we must perform the same operation for users and context. We can see then, that each of the three actors—building, users and context—are acted on by the other two and act on the other two. Each of the three causes changes in the other two and is changed by the other two. The network is in constant motion for the life of the building.

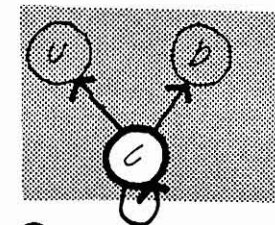
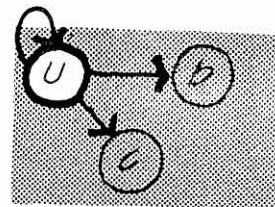

When we view our design situation in this way, it becomes clear that our design responsibility should be focused on the lines of force in the diagram and not only on the building, users and context themselves.

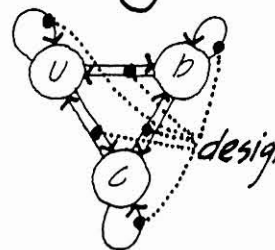

**It behooves us to not only know something about the compositional characters of buildings, people and contexts but also about how they affect themselves and each other.**

Every building project involves some degree of remodeling because of the inevitable modification of the context at and around our building. It is impossible to place our building on its site without changing the existing conditions. We must determine what to retain, reinforce, accent, reduce, modify or eliminate.



**The implanting of our building on the site will always result in a remodeling of the site. Our goal should always be to leave our site better than we found it.**

# BEING THOROUGH

As in all predesign research, thoroughness in identifying, collecting and presenting the information is vital to designing a project that is responsive to its contextual situation. We cannot respond to site conditions that we are not aware of and we must not allow the relationships between our building and its context to be accidental due to inadequate or faulty information.

A half done contextual analysis is probably more dangerous than not doing one at all.

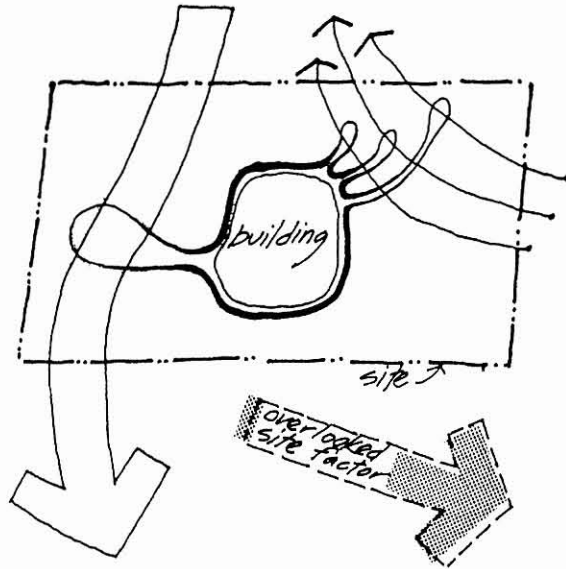

It is easy to convince ourselves that we have done our job in researching the context if we have some data (however incomplete) about the site. We proceed with design thinking that if we deal with what we know about the site, even though it is an incomplete picture, we will have met our responsibilities as designers.

This situation is similar to a doctor prescribing a remedy based on an incomplete diagnosis of the patient. In contextual

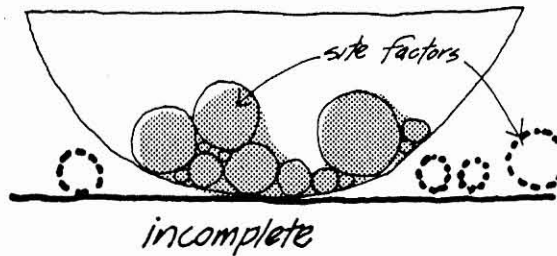
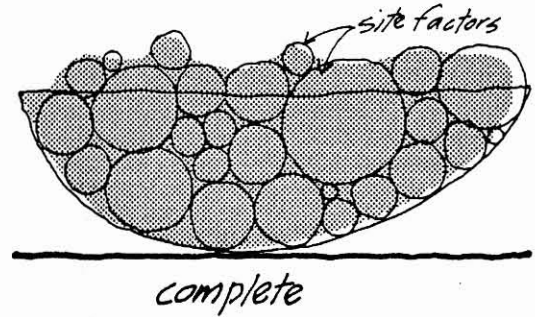

analysis there is always the nagging feeling that there are some important design implications that lie one more step beyond where we have ended our study. We can never know too much about our site. Time and budget restrictions eventually force us to call the study "complete." It is important to develop the ability to do our analyses efficiently so that we can do as thorough a job as possible within our time and fiscal constraints.

Aside from the professional competence issue of thoroughly addressing all site con-

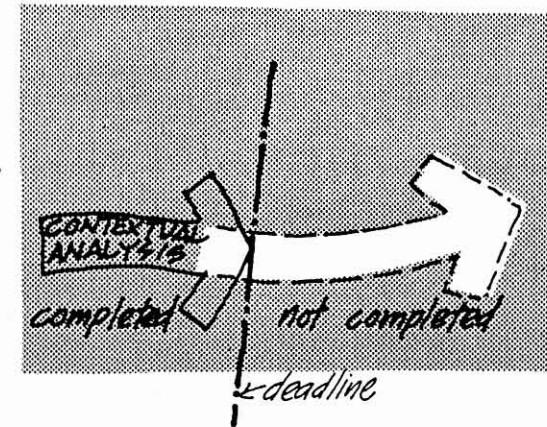
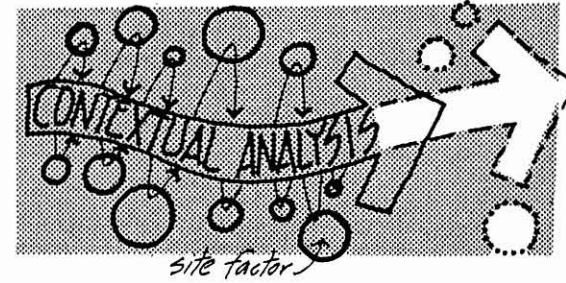

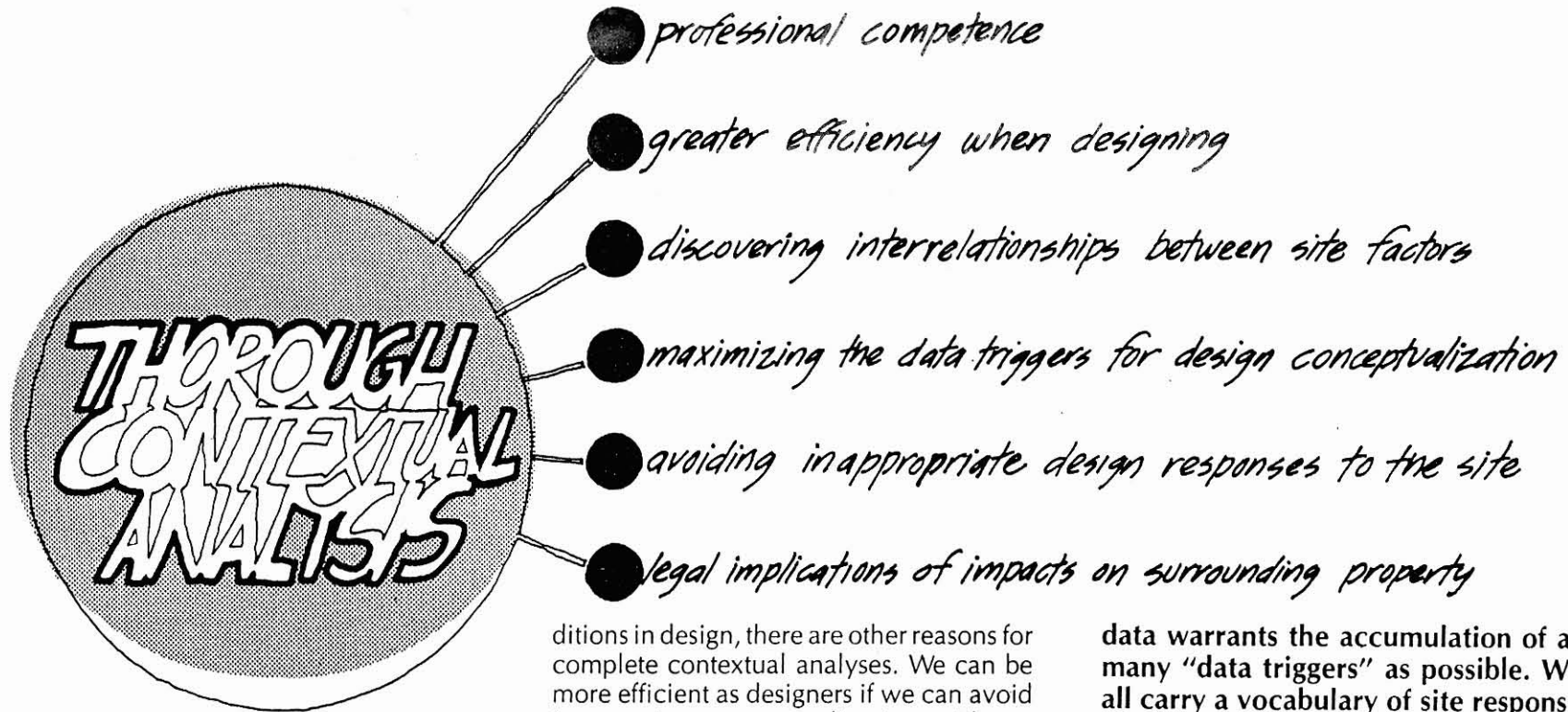

ditions in design, there are other reasons for complete contextual analyses. We can be more efficient as designers if we can avoid interrupting conceptualization with research. It is better to get it all the first time to avoid having to continually go back to repeat our efforts in site research. By having all the data at one time we can see the interrelationships of the data and use this as a catalyst in concept getting.

**Data synthesis, comparison and manipulation are obviously much richer if we are able to perform these operations with all of the data at hand. The view of predesign research as a triggering device to evoke appropriate formal vocabularies for responding to the**

**data warrants the accumulation of as many "data triggers" as possible. We all carry a vocabulary of site response concepts, a set of ways for handling different site conditions and requirements. Individual site characteristics trigger certain conceptual sets from our vocabulary of possible responses. If data is missing from the site analysis, certain site design concepts may not be evoked.**

This would deny our final scheme a richer and more complete set of site concepts and risk accidental and inappropriate responses to particular site conditions out of negligence.



There are also legal implications related to the thoroughness of contextual analysis and site design. We must be especially careful to attend to the impacts of our site concepts on adjacent and surrounding property. Inadvertent design decisions based on incomplete site data may result in negative consequences for the neighbors of our project both during construction and after our project is complete and in use. Blockage of neighborhood water drainage patterns as they enter our site may cause flooding. Rerouting drainage patterns so that water leaves our site in a different place may result in water damage. Our building placement may block views from adjacent structures. The vehicular traffic generated by our facility may increase the congestion and noise level in the neighborhood. Excavation of our site could cause footing damage to nearby buildings. Sun reflection off our building may result in increased cooling loads in neighboring buildings or create traffic hazards for drivers near our site due to glare. Shadows cast by our structure could damage landscaping of neighbors or deny them access to the sun for solar collectors. All these situations and others are potential negative consequences of our designs on adjacent property that have legal implications for both our clients and ourselves. Thorough site analysis and attention to detail during site use conceptualization are vital if we are to avoid the negative situations and achieve the positive ones.

If we hope to do a thorough contextual analysis, there are several things we should remember about the data we are

collecting.

**It is important not to do the analysis "at long range" but to actually go to the site and feel it.**

See the views, listen to the sounds, look at the activity. Walk or drive the site to get a sense of the time-distance factor between boundaries and to feel how the contours change. It is important to judge first hand the value of on site amenities such as trees.

**The issue of time must be applied to all our site information.**

We must have some idea about how long a certain event or pressure lasts, when it peaks, when it starts and ends, how it changes over the course of a year, month, week or day.

It is also helpful if we can project future conditions on and around the site such as zoning trends, widening of streets, future traffic plans or the likelihood of certain building types locating on adjacent or nearby property. For each fact we collect we should ask ourselves about the future with respect to that particular category. Our building will occupy the site for a long time. We want it to effectively respond to all surrounding conditions over its life span.

**It is desirable to look at the next contextual layer of issues beyond the ones we are addressing.**

Contextual analyses are theoretically open ended in that there are no inherent logical stopping points. We could continue to

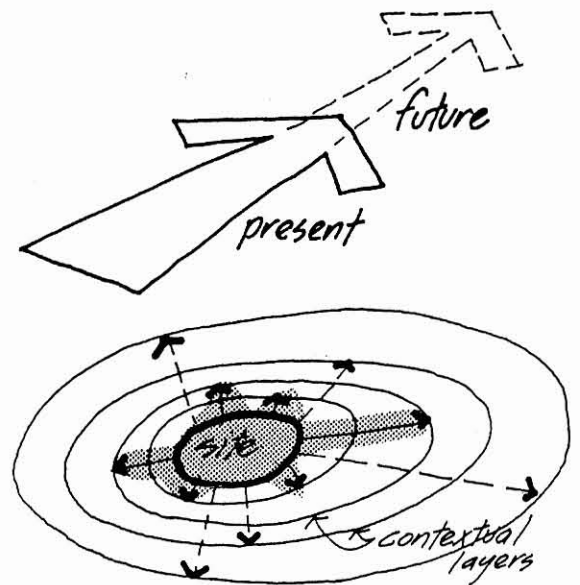
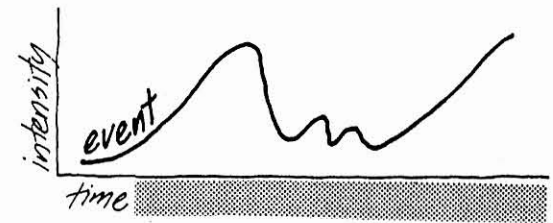
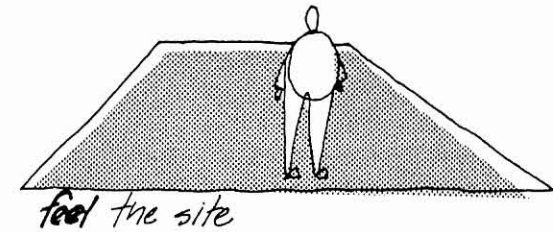

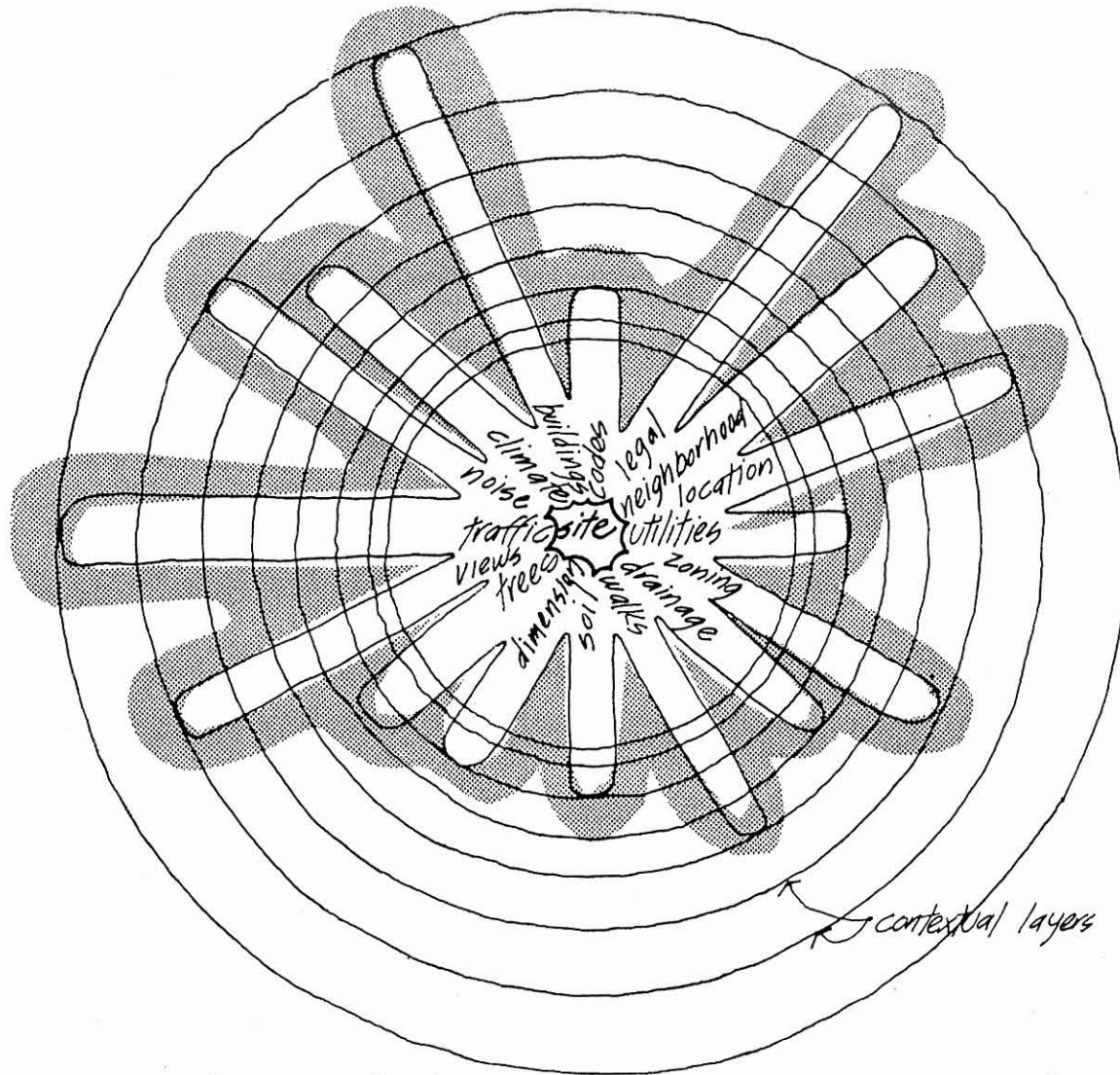

*extension of site factor analysis through contextual layers*

analyze the contexts of the contexts well beyond issues that are architecturally relevant. On the other hand there is sometimes a temptation to arbitrarily terminate our analysis before we should. The important point here is to think about the appropriate extension of the analysis for each piece of information. How far do we go with our data collection for each information type? Examples include deciding how many blocks beyond our site to incorporate in the analysis, whether to analyze what created existing traffic patterns, whether to infer certain things about the neighborhood by what we see and whether to conduct house to house interviews. These judgments all involve decisions on our part about the importance and relevancy of the information to either the verification of data or to design. In contextual analysis we are constantly making judgments about how deeply or accurately we must research a particular site topic. This issue is being raised not to provide an excuse for a sloppy job but to recognize that the "absolutely complete" contextual analysis does not exist and that under the pressure of time we must be somewhat selective about what we address in our site study. The goal is a contextual analysis researched through all its contexts of contexts. The reality is always something short of that.

**Our contextual analysis should record what information is "hard" (non-negotiable) and what is "soft."**

Soft data is that which deals with site conditions that can be changed or that do not absolutely have to be addressed or re-

sponded to in design. Hard data involves things like site boundary, legal description, site area and utility locations. Some things that we might classify as hard data are actually changeable such as contours, zoning, setbacks and trees. It is helpful to classify the information according to "firmness" because it provides a sense of the required sequence of attention to data when we begin design. We generally must cope with the hard data first in our early site decisions.

**There should be a sense of priority about the information we collect and record.**

*design decisions in response to site*

**HARD DATA**

1ST

**SOFT DATA**

2ND

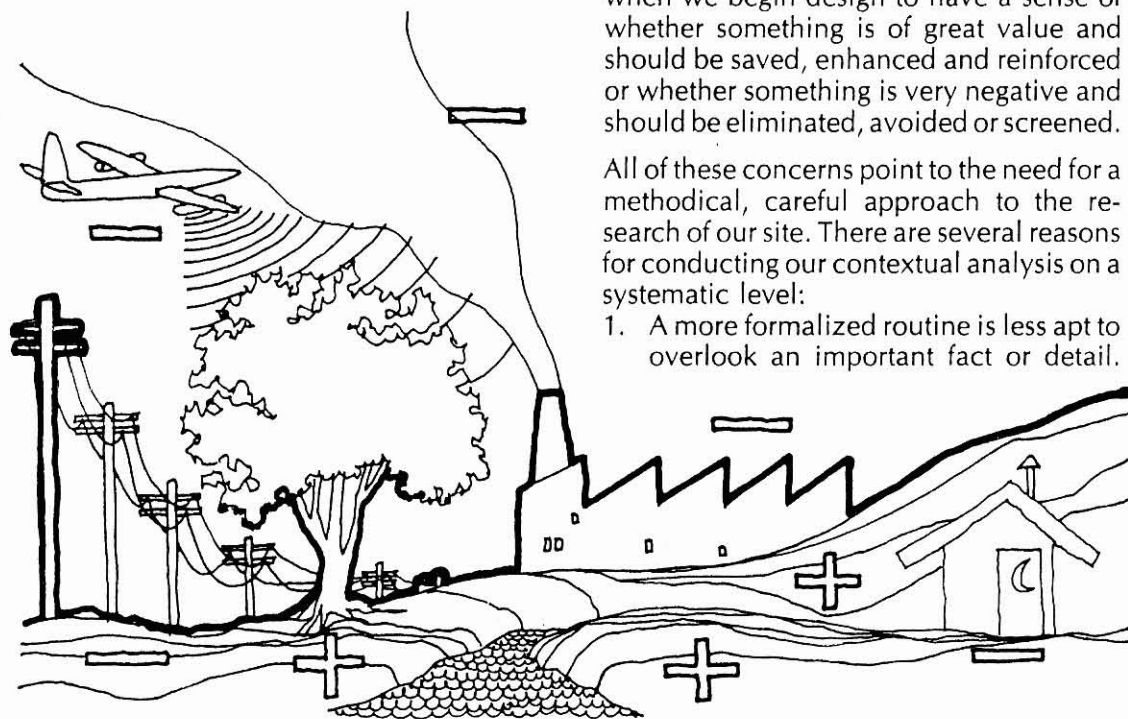

This is normally a result of the intensity of the site conditions and whether they are judged positive or negative. It is useful when we begin design to have a sense of whether something is of great value and should be saved, enhanced and reinforced or whether something is very negative and should be eliminated, avoided or screened.

All of these concerns point to the need for a methodical, careful approach to the research of our site. There are several reasons for conducting our contextual analysis on a systematic level:

1. A more formalized routine is less apt to overlook an important fact or detail.

2. A systematic approach more easily permits us to cope with information overload in complex situations.
3. A fine-grained approach to analysis fosters a fine-grained approach to design synthesis where contextual opportunities and problems have less of a chance to "slip through the cracks" and thus be left behind during design synthesis.
4. The more individual contextual factors we uncover and document in analysis of the site, the more cues we provide for ourselves in triggering site response concepts.

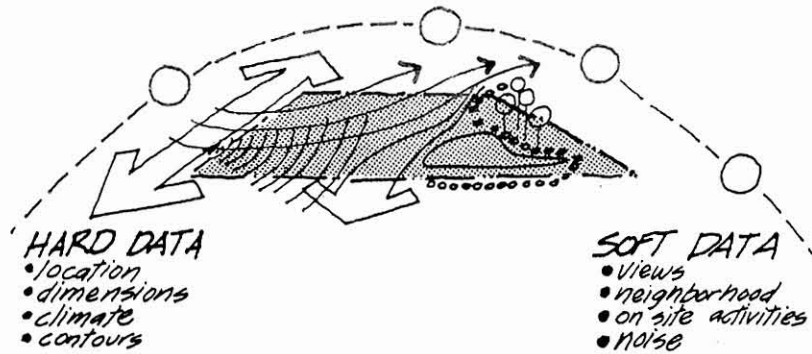

## KINDS OF INFORMATION

The kinds of information collected for our contextual analysis basically involve an inventory of existing and projected site conditions. We are not concerned with design responses to the site at this stage but rather with finding out all we can about the site. We are interested in facts. The facts about our site will always include both hard and soft data. The hard data usually relate to physical site factors and involve no judgments about their existence or nature. Typical hard data would be site location, dimensions, contours, on site features and climate. Soft data may involve some value judgments on our part in conducting

the contextual analysis. These deal primarily with the sensory and human aspects of the site that are not quantitative and which require an opinion about the existence and positive or negative characteristics of certain site qualities. Typical examples include good and bad views from the site, best approach directions to the site in terms of view, existence of odors and extent to which they are annoying, presence of existing on site human activities and their value (informal playground, gathering spot for unemployed workers, neighborhood fairs and festivals) and types of noises and the extent to which they are disruptive. This "soft data", although it initially involves judgments, tends to become "hard data" once it is documented in the contextual analysis. It is important to keep in mind that

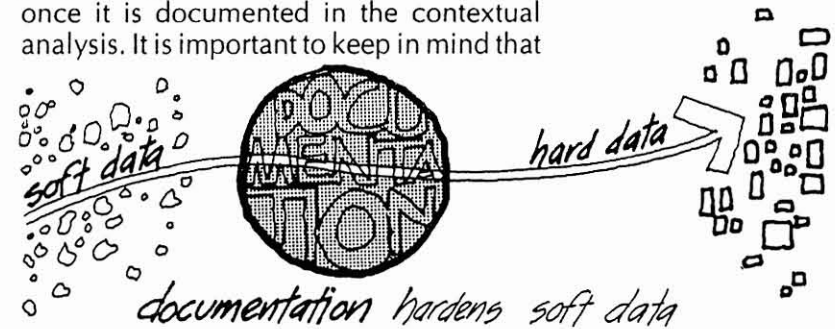

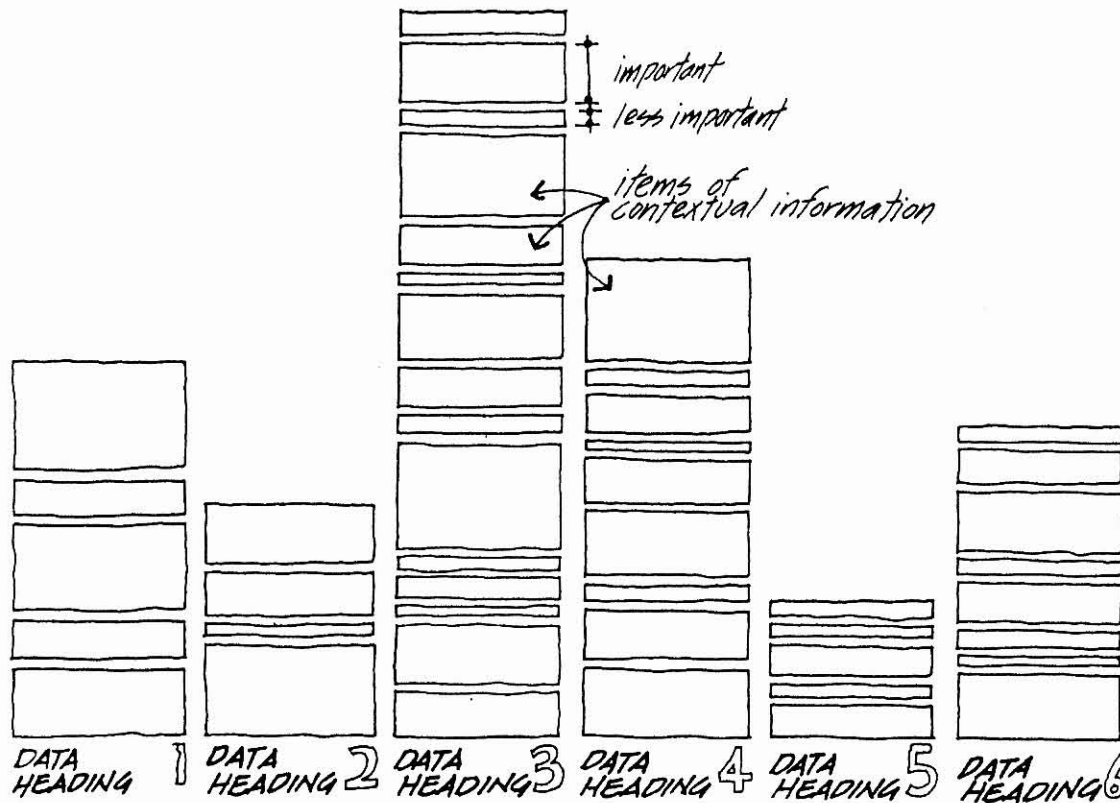

those issues that involve opinions are always open to interpretation in design and are usually the most negotiable when designing for the site in schematics.

**In attempting to organize the types of information that we collect about a site, there are several headings that**

**seem useful in classifying the data. We should never expect the amount and importance of site data to be equal under each of these headings. Each site is different and the imbalance in how the information is distributed among the headings and the different patterns of emphasis given to the information**

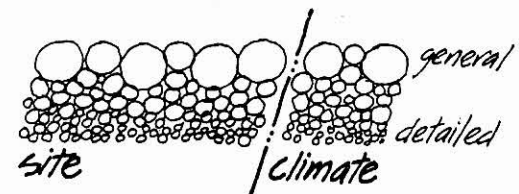

**communicate a great deal to us when we begin to respond to the contextual analysis in design.**

The data outline presented next has no particular meaning behind its sequence other than the fact that it separates site data from climate data and proceeds from general overview issues to more detailed ones.

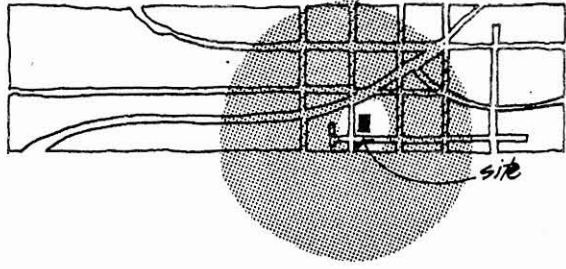

**LOCATION** May include state map and city map showing location of site in relation to city as a whole. City map may also show distances and travel times to related functions in other parts of the city.

**NEIGHBORHOOD CONTEXT** Presents the immediate surroundings of the site for perhaps three to four blocks beyond the site boundary. This may be extended further to include an important factor or because of the scale of the project. Map may show existing and projected uses, buildings, zoning and any other conditions that may have an impact on our project.

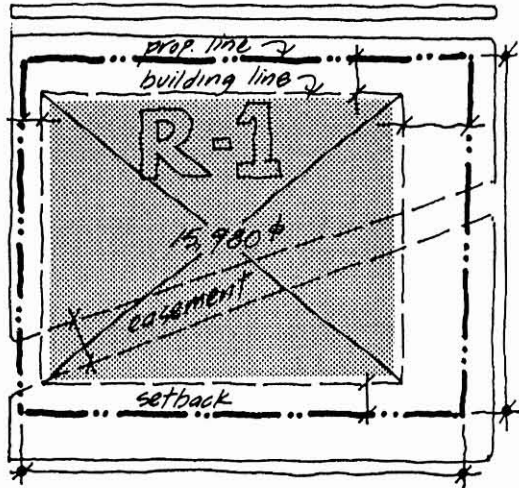
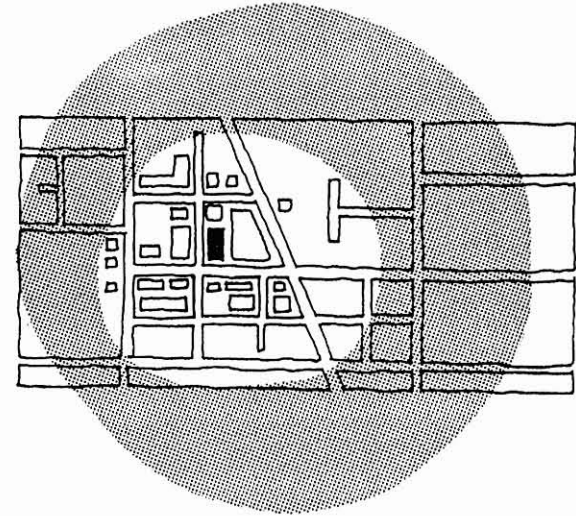

**SIZE AND ZONING** Documents all the dimensional aspects of the site including boundaries, location and dimension of easements and present zoning classification with all its dimensional implications (setbacks, height restrictions, parking formulas, allowed uses, etc.) and buildable area (land available for the project after all setbacks and easements have been subtracted). Analysis should also document the present and projected zoning trends, plans by the city transportation department to widen roads (change rights of way) and any other trend that might affect our project in the future.

**LEGAL** This category presents the legal description of the property, covenants and restrictions, present ownership, present governmental jurisdiction (city or county) and any future projections that may influence the project (such as the fact that the site is in a future city urban renewal area or within the boundaries of eventual university expansion).

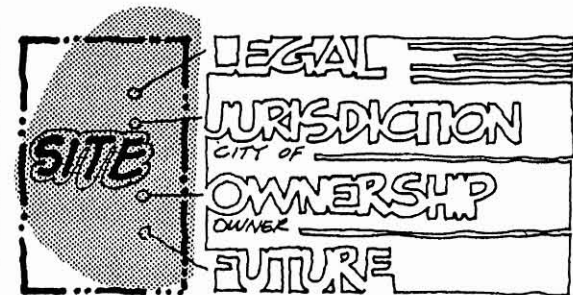

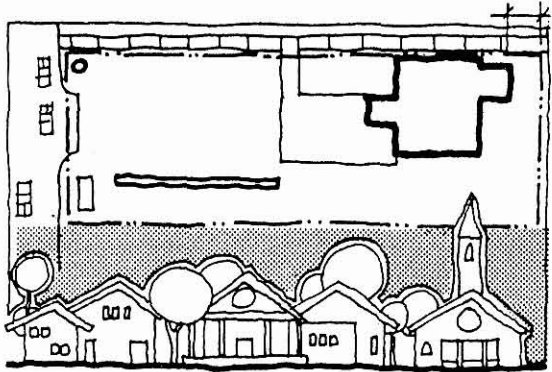

**NATURAL PHYSICAL FEATURES**

Includes contours, drainage patterns, soil type and bearing capacity, trees, rocks, ridges, peaks, valleys, pools and ponds.

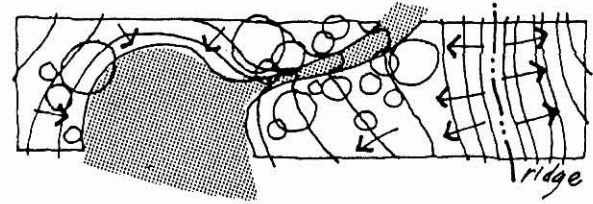

**MAN-MADE FEATURES**

Documents on site conditions such as buildings, walls, drives, curb cuts, hydrants, power poles and paving patterns. Off site features may include characteristics of surrounding development such as scale, roof forms, fenestration patterns, setbacks, materials, colors, open spaces, visual axes, paving patterns, landscaping materials and patterns, porosity and assertiveness of wall forms and accessories and details.

**CIRCULATION**

Presents all vehicular and pedestrian movement patterns on and around the site. Data includes duration and peak loads for surrounding vehicular traffic and pedestrian movement, bus stops, site access edges, traffic generators, service truck access and intermittent traffic (parades, fire truck routes, concerts at nearby auditorium). Traffic analysis should include future projections insofar as they can be made.

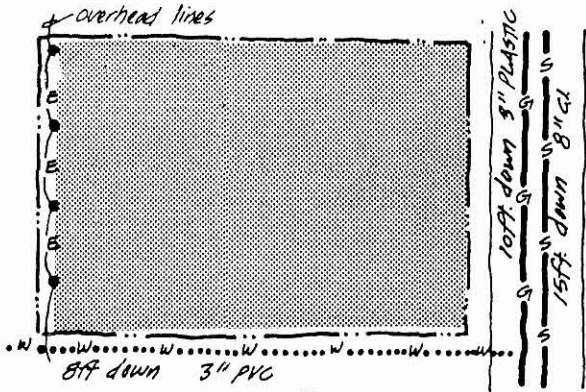
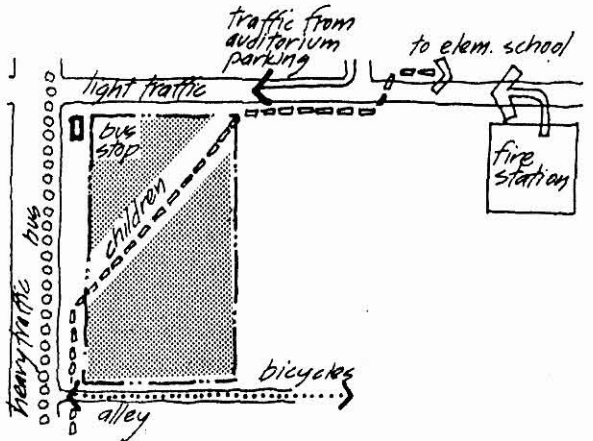

**UTILITIES**

This category deals with the type, capacity and location of all utilities on, adjacent to and near the site. Typical utility types include electricity, gas, sewer, water and telephone. Where utilities are some distance from the site, those dimensions should be given. It is useful to document the depths of utilities when they are underground as well as the pipe material and diameter.

**SENSORY** Documents the visual, audible, tactile and olfactory aspects of the site. Typical issues are views to and from the site and noise generated around the site. It is of value to record the type, duration, intensity and quality (positive or negative) of the sensory issues. As discussed earlier, this often involves making some judgments about the relative desirability of the different sensory conditions on and around the site.

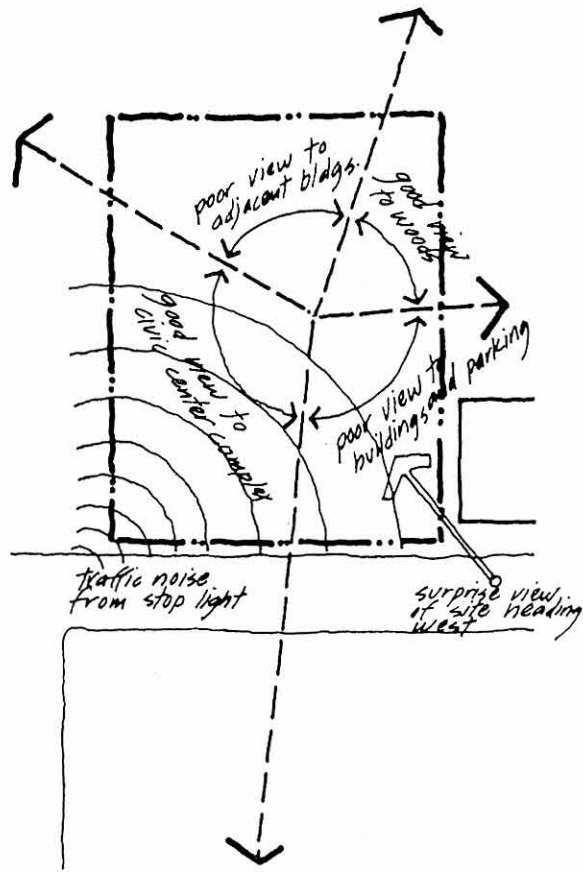

**HUMAN AND CULTURAL** Includes an analysis of the surrounding neighborhood in terms of cultural, psychological, behavioral and sociological aspects. This category is different from "Neighborhood Context" listed earlier in that the latter addresses the physical while this category deals with the activities, human relationships and patterns of human characteristics. Issues here might involve population age, ethnic patterns, density, employment patterns, values, income and family structure. Also of importance are any scheduled or informal activities in the neighborhood such as festivals, parades or crafts fairs. Vandalism and crime patterns, although not pleasant, are of value to designers when conceptualizing site zoning and building design.

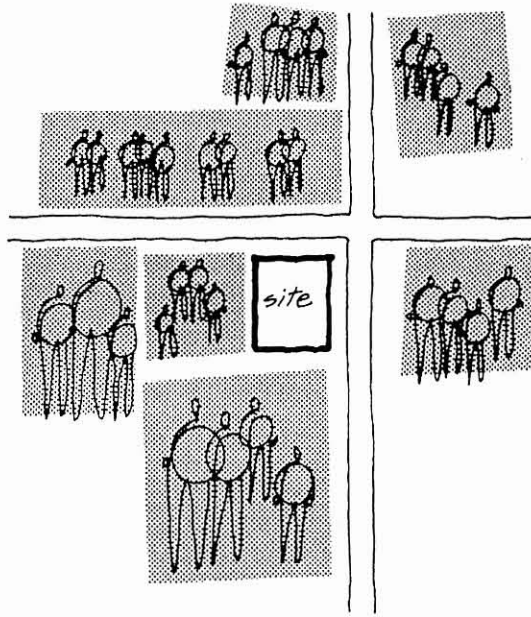

**CLIMATE** Presents all the pertinent climate conditions such as rainfall, snowfall, humidity and temperature variations over the months of the year. Also included are prevailing wind directions, sun-path and vertical sun angles as they change over the year and potential natural catastrophes such as tornados, hurricanes and earthquakes. It is helpful to know not only how climate conditions vary over a typical year but also what the critical conditions might be (maximum daily rainfall, peak wind velocity).

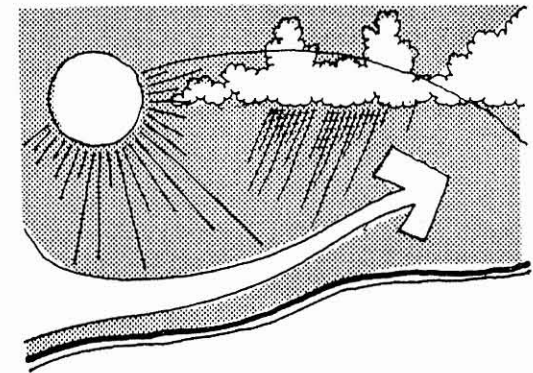



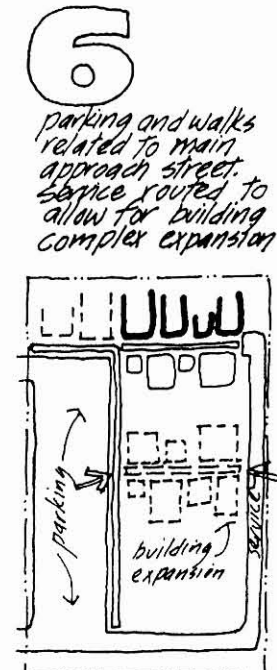
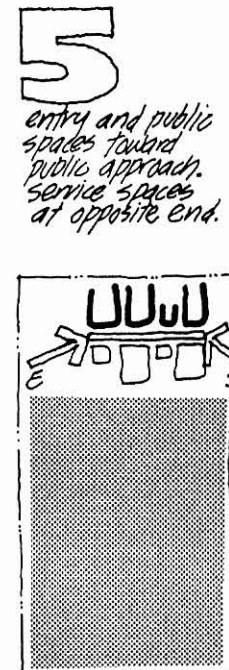
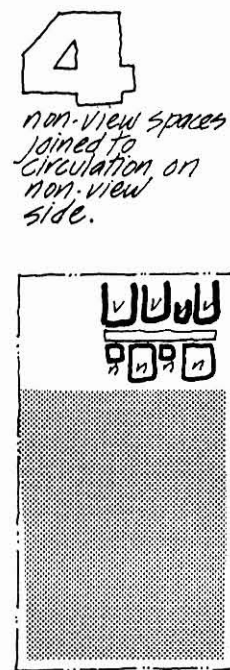
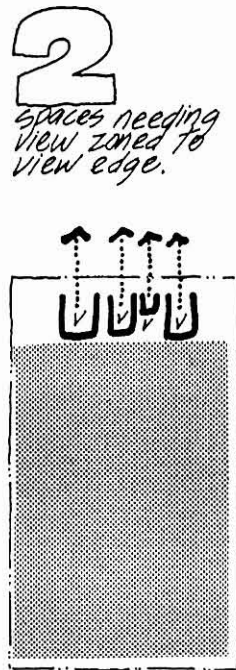
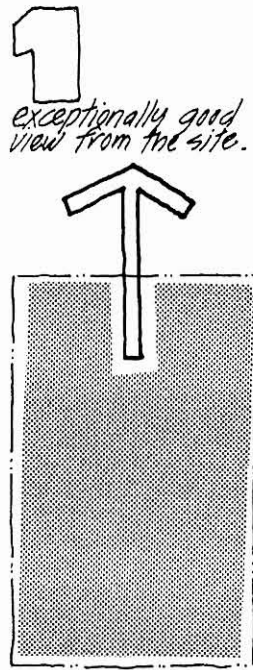

## IMPLICATIONS FOR DESIGN

Contextual analysis is a prelude to designing for context. It involves knowing what we have to work with in terms of site before we begin to work with it in site zoning. Like function, image or building envelope, it is another way of entering the problem, of making our first conceptual decisions which form the designer-made context for subsequent decisions.

Although the facts we collect about our site may be influenced by the building images that inevitably come to mind as we do the contextual analysis, we should attempt to keep conceptualization separate from the contextual analysis. The contextual analysis should be an inventory of existing and projected conditions assuming no new building on the site so that when we begin to design for the site we do not confuse what is actually there now with what we wish was there or hope to put there.

*site zoning concept initiated by a response to view.*

It is useful in discussing the influence of contextual analysis on design to differentiate between function and context as forces which locate building spaces and activities on the site. Function tends to locate building spaces in an introverted way in that they are primarily looking inward to each other for the rationale behind their positions in the scheme. Context, on the other hand, wants the spaces to migrate to different positions on the site in response to conditions outside the building. In function, the attraction is between spaces. In context, the attraction is between spaces and external site conditions. Usually in a design problem these two (and all the other) project issues pull and push the spaces to determine their final placement in the scheme. They are in a very real sense competing with each other to determine the building form.

Some examples of situations that might cause a space or activity to be placed in the scheme due to external linkages to context are presented below.

Activities requiring or desiring a view.

Activities that should be zoned away from noise.

Activities that should strongly relate to on site pedestrian circulation patterns.

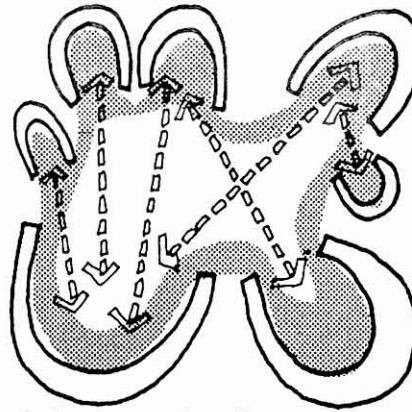
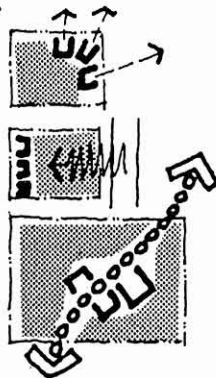

*placement of spaces due to internal functional relationships*

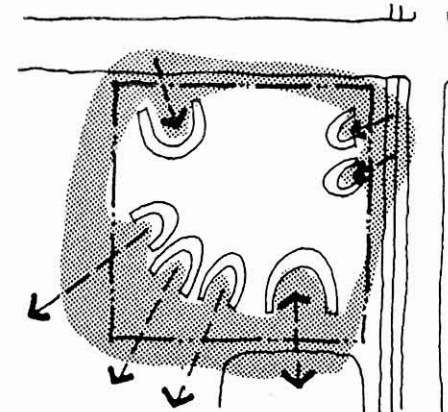

*placement of spaces due to relation to external context*

Operations needing access to delivery and pick-up vehicles.

Building entry located to relate to primary approach direction.

Zoning of parking areas away from view lines to building.

Activities needing indirect natural lighting.

Activities needing direct sunlight.

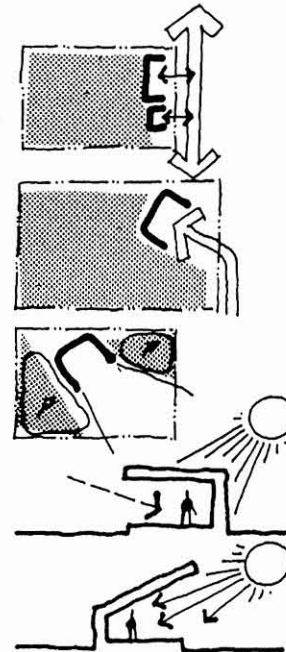

Operations needing shelter from high activity zones.

Activities needing direct access for vehicles.

Integration of form with surrounding contextual images.

Relationship of spaces to existing scale and geometric patterns.

Spaces needing their own controlled exterior environment.

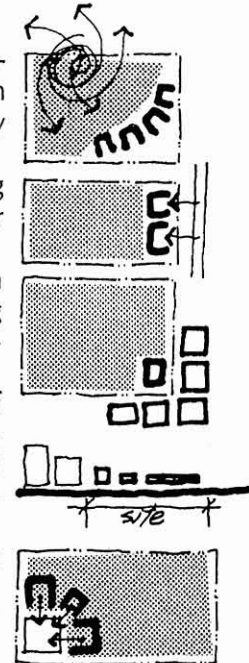

Our first efforts at optimum placement of functions or spaces on the site in response to contextual pressures may involve any of three approaches.

1. Where function is considered a more critical form-giving determinant than context, we may place the bubble diagram on the site and allow the spaces to migrate and shift within the bubble so that their orientations and placements relate to the appropriate site conditions. Here the connecting lines between the spaces in the bubble are made elastic while still remaining connected to the space bubbles so that the functional ties are always maintained while we are searching for a contextually responsive placement of spaces.

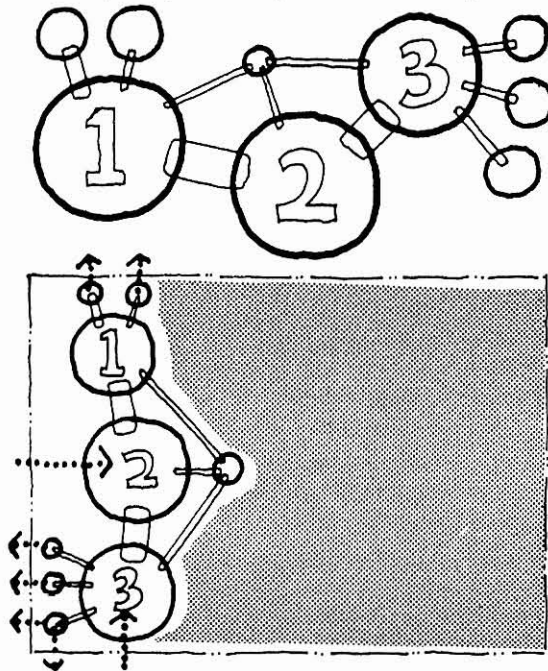

2. Where relation to context is judged to be more important than internal functional efficiency, we may take each function or space and place it in its optimum zone on the site independently of the other spaces. When all the spaces have been placed (including exterior spaces) then we may begin to condense our spaces and knit them together with a circulation system.

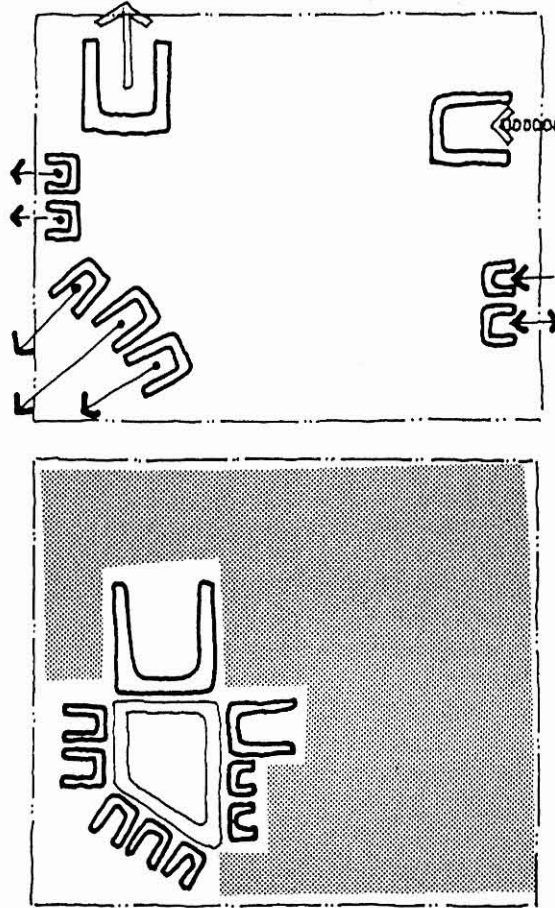

3. The third approach is appropriate where the project is particularly large with several site components. Here we may need to deal with the placement of our building or buildings as wholes before we can address the location of their spaces. In this approach the principles and intentions are no different than those in the first two approaches. The scale of the components we are manipulating on the site is simply larger. Once our buildings are placed in zones on the site, then we may use either of the first two approaches to zone the building spaces in response to their context.

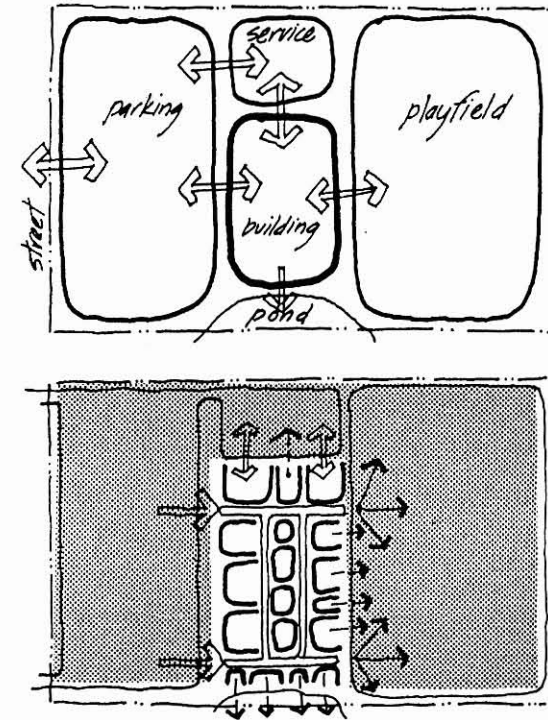

Reasons for locating a building in a particular area of the site may involve soil bearing conditions, contours that minimize earth work during construction, ridges to take advantage of views or breezes, streets or corners that ensure high visibility to the building, alleys that allow easy service access, site scars that have already caused disruption (collect existing scars with the scars caused by construction) or the avoidance of some particularly valuable asset that should be preserved (trees) or some particularly negative condition (poor view or noise).

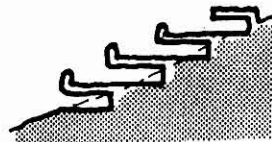

**It is important to remember that site design and building and space placement can involve sectional issues as well as plan issues.**

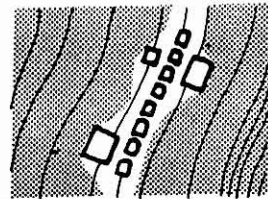

Relation of floors to contours, heights of spaces in relation to views, stepping of spaces down hillsides and stacking of spaces in relation to contours and neighborhood scale are a few of the potential reasons to study the zoning of our facility on the site in section as well as in plan.

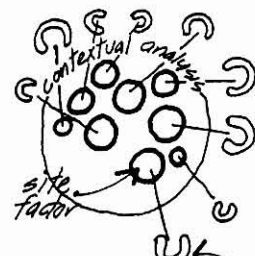

*suggested design idea for dealing with site factor*

A thorough contextual analysis gives us confidence that we have the site conditions all recorded. That confidence facilitates the conceptualization of site responses in design and contributes to the heuristic process of idea formulation. In doing the contextual analysis and engaging the site issues through diagramming, we trigger design response images for dealing with the site.

**The contextual analysis acts as a switch to recall the parts of our design vocabularies that apply to the site problems and opportunities. The role of context-**

**ual analysis as a stimulant for conceptualization is vital to responsible design. It helps to ensure that there is an appropriateness to those design ideas that surface in our minds in that they were triggered by the relevant project issues, conditions and needs and not arbitrarily fabricated and imposed on the project.**

**The contextual analysis itself will never create the design responses. Too often we mistakenly believe that if only we analyze long enough, we will be led to the solution. This will never happen.**

The bridging of the analysis-synthesis "gap" has to be a two-way affair. We must analyze the context to trigger design responses, but the design responses or vocabularies must be there to be triggered. As designers we must continually work to expand and deepen our vocabulary of architectural forms and concepts so that there is something there to draw upon when we "flip the switch" through analysis. We should know many ways of taking advantage of a good view, numerous ways to buffer our spaces against outside noise and several ways to ascend to our building from a parking lot. These conceptual solution types constitute the design vocabulary that we accumulate from reading, travel, past projects we have designed and visiting buildings. Analysis will give us the conditions but not the responses. It will tell us that we have a great view but not what to do about it. We must draw from our vocabulary of design responses for the appropriate concepts.

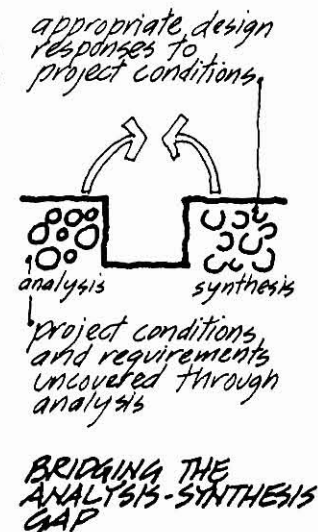

**DIAGRAMMING  
SITE  
INFORMATION**

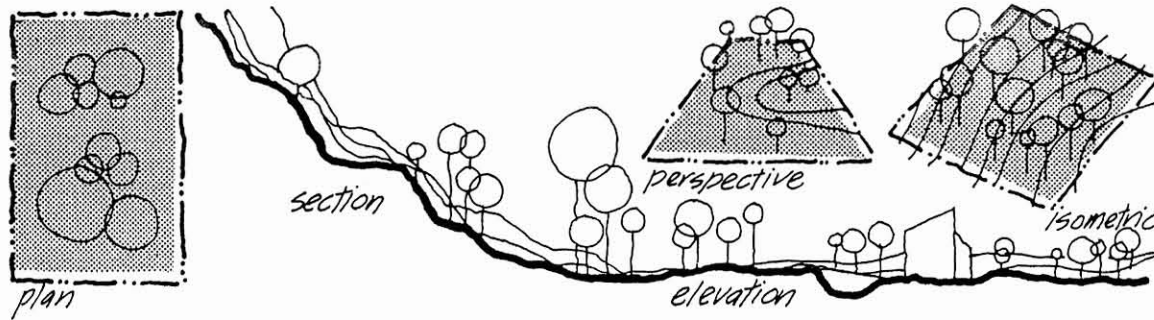

## OVERVIEW

Diagramming the information learned through contextual analysis may utilize any of the conventional drawing frameworks to record the data. We may graphically express our site information in plan, section, elevation, perspective, isometric or any of the other types of drawings available to us. The types of drawings we use should be sympathetic to the type of information we are recording. Some data is better expressed in plan, some in section, some in perspective, etc. Normally there are two components to any site information diagram. First, we must have a referent drawing of the site to provide a context for the particular site information we want to record. Second, we must diagram the site fact itself. The referent drawing may be a simple plan of the site boundaries with bordering streets or a section through the site showing only the ground plane. We use these simple site drawings as frameworks for diagramming the particular site issues that we wish to express. There are two rather different postures we may assume regarding the recording of the site information over these referent drawings. The first we may call the composite or integrated approach where we attempt to diagram as many different site issues as we can over one referent drawing. Here, different types of site data are superimposed over each other so that we can more easily see the relationships between the information. In this approach we must make sure that the drawing does not become muddled and confusing and that the most important site

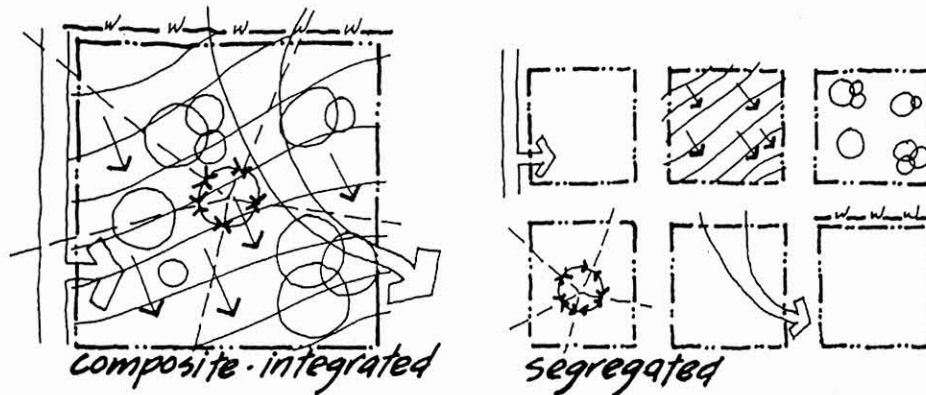
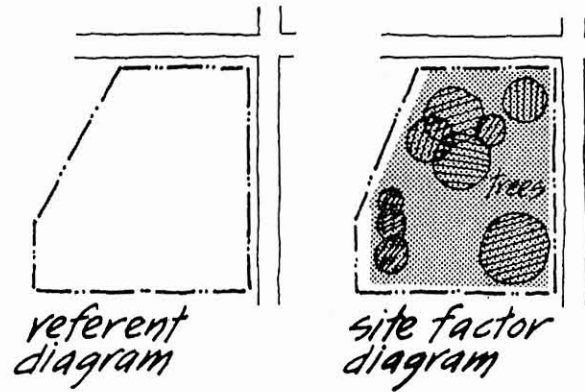

*in the contextual analysis of a site.....*

*some diagrams may be composite.....*

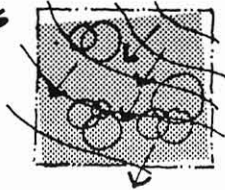

*others may be segregated.*

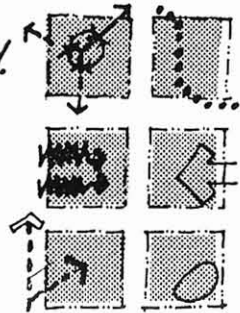

information has been expressed with the strongest diagrams. The second approach segregates each piece of site information to a separate referent drawing. This method values the expression of each issue separately so that it can be easily understood. By dealing with each fact individually we may be less likely to ignore something. Keeping these two approaches pure and unadulterated is not important. Where it is appropriate to our situation it is perfectly permissible to use both methods within the same contextual analysis.

The diagrammatic forms that we may use to actually record our site information over the referent drawings are many and varied. There are no rules for the forms these must take and no universally agreed upon vocabulary for them.

1 *design the diagrammatic form.*



2 *refine and simplify the diagram form*

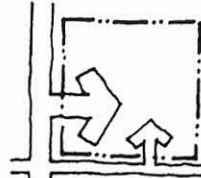

3 *emphasize the essential graphic information*

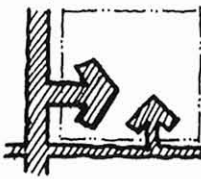

4 *incorporate labels and notes*

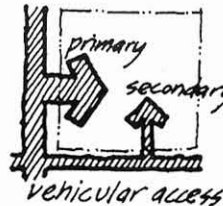

**We should begin to develop our own vocabulary of diagrammatic forms so that they may become second nature for us and may be used as an effective graphic shorthand for documenting site conditions. There are essentially four steps to diagramming any site fact. We must design the initial diagrammatic form, refine and simplify it, emphasize and clarify the meaning through graphic hierarchy and emphasis and finally introduce whatever notes and labeling are necessary.**

● *region*

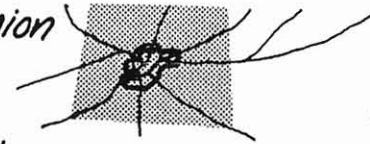

● *city*



● *neighborhood*

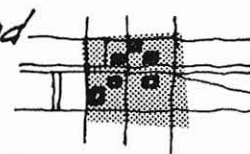

● *parcel*



● *building*

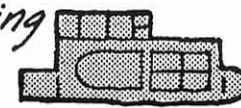

● *space*

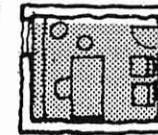

Contextual analysis may be applied to situations of any scale and is relevant to both exterior and interior project issues. We may analyze a region, a city, a neighborhood, a parcel of land, the interior of an existing building or the interior of a single existing interior space. The discussion that follows will deal principally with the analysis of single parcels of land. Some attention will also be given to the contextual analysis of interior space under "Other Contextual Analysis Forms."

# PROCESS

## ISSUE IDENTIFICATION

The first step in conducting a contextual analysis is to identify those issues we wish to analyze and to diagrammatically document. As discussed previously, our goal should be to analyze all relevant issues about the site because thoroughness is vital to project success.

It is useful in choosing from among the available site issue categories to let our choices be influenced by at least two important inputs:

1. We should think about the nature of the project, its needs, requirements and critical issues.

What is the essence of the project? What is the building's reason for being? What are its major goals and objectives? What roles can the building play in enhancing the site and its surroundings? All of these concerns should help us to anticipate the kind of site data that will be needed during the design phase of the project.

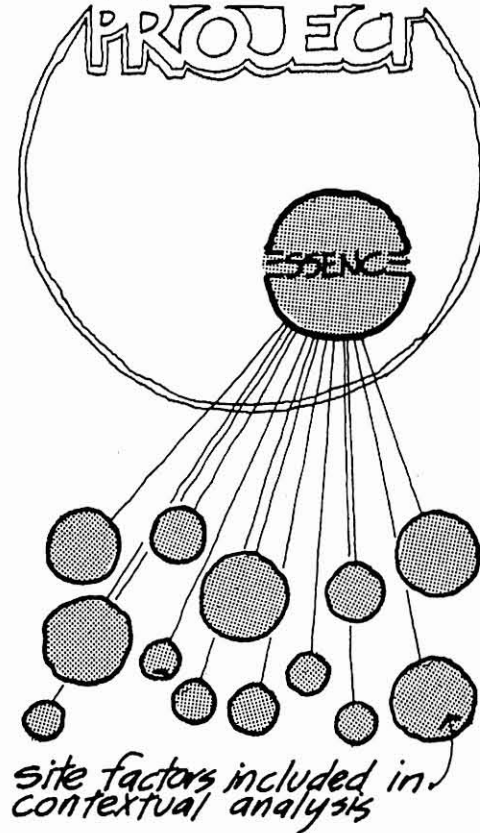

2. Site analysis should never be done at "long range." We should always see the site first hand, walk or drive the contours and boundaries, see the views and on site amenities, listen to the sounds and personally assimilate the scale and pulse of the neighborhood.

**This "hands-on" direct encounter with site from a personal and sensory point of view gives us another set of clues for choosing the types of site information that should be addressed in our contextual analysis.**

The visit to the site allows us to develop a sense of what is unique, valuable and important about the site.

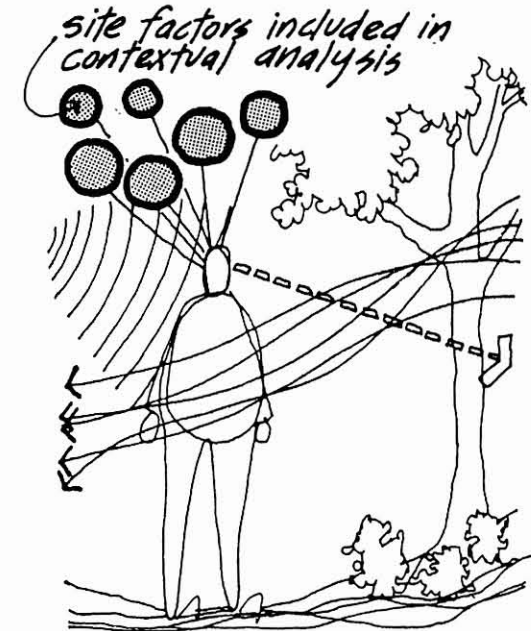





Both of the previous techniques for focusing on what should be analyzed may benefit from a checklist of potential contextual issues. This checklist will help ensure that we do not forget any important site factor and will assist us to more efficiently identify the site concerns to be included in our analysis. We should add to our list each time we encounter a new site issue so that over time the list becomes more and more comprehensive. A prototypical checklist of potential site issues follows.

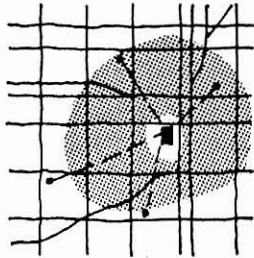

### 1. Location

- a. Location of the city in the state including relationship to roads, cities, etc.
- b. Location of the site neighborhood in the city.
- c. Location of the site in the neighborhood.
- d. Distances and travel times between the site and locations of other related functions in the city.

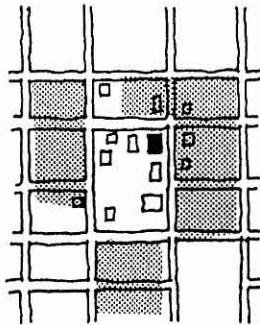

### 2. Neighborhood Context

- a. Map of the neighborhood indicating existing and projected property zoning.
- b. Existing and projected building uses in the neighborhood.
- c. Age or condition of the neighborhood buildings.
- d. Present and future uses of exterior spaces in the neighborhood.
- e. Any strong vehicular or pedestrian traffic generating functions in the neighborhood.
- f. Existing and projected vehicular movement patterns. Major and

minor streets, routes of service vehicles such as trash, bus routes and stops.

- g. Solid-void space relationships.
  - h. Street lighting patterns.
  - i. Architectural patterns such as roof forms, fenestration, materials, color, landscaping, formal porosity, relationship to street, car storage strategies, building height, sculptural vigor, etc.
  - j. Neighborhood classifications that might place special restrictions or responsibilities on our design work such as "historic district."
  - k. Nearby buildings of particular value or significance.
  - l. Fragile images or situations that should be preserved.
  - m. Sun and shade patterns at different times of the year.
  - n. Major contour and drainage patterns.
- ### 3. Size and Zoning
- a. Dimensions of the boundaries of our site.
  - b. Dimensions of the street rights of way around our site.
  - c. Location and dimensions of easements.
  - d. Present site zoning classification.
  - e. Front, back and side yard setbacks required by zoning classification.
  - f. Square feet of buildable area inside setbacks (should also subtract easements).
  - g. Building height restrictions required by zoning classification.
  - h. Zoning formula for determining required parking based on the type of

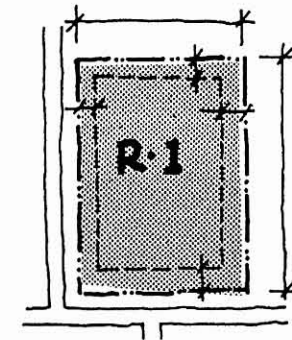

- building to occupy the site.
- i. The number of parking spaces required (if we know the building area).
- j. Any conflicts between what the present zoning classification allows and the functions we are planning for the site.
- k. Zoning classifications that the site would need to be changed to in order to accommodate all the planned functions.
- l. Any projected changes that would alter the dimensional characteristics of the site such as street widenings or purchase of additional property.

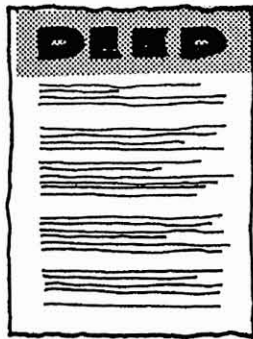

#### 4. Legal

- a. Legal description of the property.
- b. Covenants and restrictions (site area usage allowed, height restrictions, screening of mechanical equipment or service yards, restrictions on rooftop elements, architectural character, design requirements in historic districts, etc.).
- c. Name of the property owner.
- d. Name of the governmental levels or agencies which have jurisdiction over the property.
- e. Any projected or potential changes in any of the above categories.

#### 5. Natural Physical Features

- a. Topographic contours.
- b. Major topographic features such as high points, low points, ridges and valleys, slopes and flat areas.



- c. Drainage patterns on the site including directions of surface drainage (perpendicular to contours), major and minor arteries of water collection (ditches, arroyos, riverbeds, creeks, etc.), major drainage patterns onto the site from adjacent property and from the site onto adjacent property and any neighborhood water-related patterns such as viaduct systems or storm sewers.
- d. Existing natural features on the site and their value in terms of preservation and reinforcement versus alteration or removal. This would also include opinions regarding permanency in terms of difficulty or expense to remove features. On site features might include trees (type and size), ground cover, rock outcroppings, ground surface texture, holes or ditches, mounds, on site water (pools, ponds, lakes, rivers) and stable or unstable areas of the site (site scars versus virgin areas).
- e. Type of soil at different levels below surface and bearing capacity of the soil. Soil type distribution over site area.

#### 6. Man-Made Features

- a. Size, shape, height and location of any on site buildings. If these are to remain, the exterior character and interior layout should also be documented. If the buildings are to be part of our project, we must do a

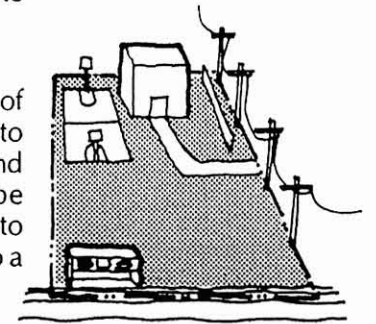

detailed building analysis of each facility.

- b. Location and type of walls, retaining walls, ramadas or fences.
- c. Location, size and character of exterior playfields, courts, patios, plazas, drives, walks or service areas.
- d. Where it may be important to our design we should record the paving patterns of man-made surfaces.
- e. Location and size of curb cuts, power poles, fire hydrants or bus stop shelters.
- f. Off site man-made features may include any of the on site items listed above and/or may involve a detailed analysis of the existing architectural character surrounding our site. This is particularly important where the architectural character will be a factor in the design of our facility (historic district, etc.). Some factors to consider in analyzing surrounding architectural character include scale, proportion, roof forms, window and door patterns, setbacks, materials, colors, textures, open space versus built space, visual axes, landscaping materials and patterns, paving textures and patterns, porosity (extent of openness) and assertiveness (ins and outs) of wall forms, connections, details and accessories, exterior lighting, outdoor furniture and car storage methods.

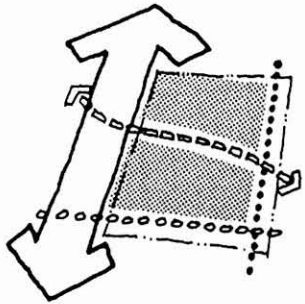

## 7. Circulation

- a. On site sidewalks, paths and other

pedestrian movement patterns including users, purposes, schedule of use and volume of use.

- b. Off site pedestrian movement patterns using the same characteristics mentioned for on site movement.
- c. If a pedestrian movement pattern is considered valuable and to be preserved or reinforced, our analysis should also include an evaluation of how the existing pattern could be improved.
- d. On site or adjacent vehicular movement patterns including type of traffic, origins and destinations, schedule, volume of traffic and peak loads. Also included should be intermittent traffic such as parades, festivals, concerts, fire truck routes, service truck fleets, etc.
- e. Off site or neighborhood vehicular movement issues such as traffic generators (buildings or uses that are significant destinations or origins of vehicular traffic) as well as the other traffic characteristics outlined under on site traffic. Adjacent or nearby parking areas that may be used for off site car storage in our project. Off site traffic patterns should also include the relation of our site to the public transportation routes, stops at or near our site, probable directions of approach to our site by the users of the new building and directions of dispersal of traffic from our building. Traffic analysis should document future

projections to the extent they can be made.

- f. Locations of probable or optimum access to our site for each type of pedestrian and vehicular traffic that will use the new building or move through the site.
- g. Travel time to walk across our site, to drive across the site or by the site where these times may be important to our design (time it takes to walk between classes at a school). It may also be useful to record the time it takes to drive to or from related locations in the city (from our site to downtown, the university, the shopping center, etc.).

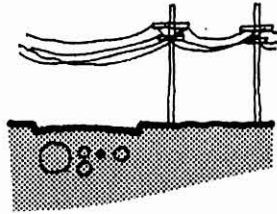

#### 8. Utilities

- a. Location, capacity and conveyance form (type of pipe, etc.) of power, gas, sewer, telephone and water utilities. This should involve the depth of each utility underground and, in the case of power, whether it is above or below grade. Location of power poles.
- b. Where utility lines stop short of our site boundaries, their distances from our site should be given.
- c. Where there are multiple opportunities to connect to utilities that are adjacent to our site, we should record those locations or edges on our site that seem to offer the best connection opportunities. This may be due to the capacities of the utility lines, contour conditions on our site in relation to sewer, the need to minimize on site utility

runs, being able to collect utility runs, bringing utilities in at the "back" of the site or dealing with site barriers or difficult soil conditions.

#### 9. Sensory

- a. Views from the site including positions on the site where the views are not blocked, what the views are of, whether the views are positive or negative, the angles within which the views can be found, whether the views change over time and the likelihood of view continuance for the long term.
- b. Views to points of interest on the site from within the site boundaries. Includes what the views are of, whether the views are positive or negative, positions on the site where the views are best and where they are blocked, the angles within which the views can be found and whether the object of the views changes over time.
- c. Views to the site from areas outside the site boundaries, including streets, walks, other buildings and vistas. Includes when the site is first seen, angles within which it is seen, most dramatic views of the property, best views of the site and areas that are viewable, particular points of interest that may be objects of views from outside our site and potential for these views to continue or be blocked by development outside our site over the long term.

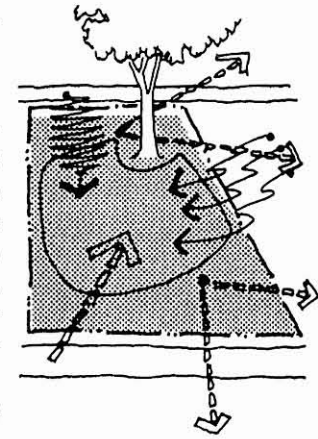

- d. Views through our site from positions outside the property. Involves the objects of the views and the various positions where the views occur, whether the views are positive or negative, the angles within which the views can be found, and the likelihood of the view targets as well as the view paths remaining open over the long term.
- e. Locations, generators, schedules, and intensities of any significant noise on or around the site. This analysis should include likelihood of continuance over the long term.
- f. Locations, generators, schedules and intensities of any significant odors, smoke or other airborne pollution on or around our site. This analysis should include likelihood of continuance over time.

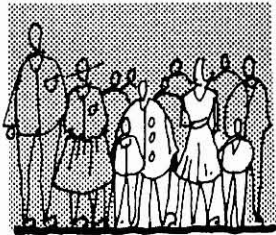

#### 10. Human and Cultural

- a. Documentation of neighborhood cultural, psychological, behavioral and sociological aspects. Potential information includes population density, age, family size, ethnic patterns, employment patterns, income, recreational preferences and informal activities or events such as festivals, parades or fairs.
- b. Negative neighborhood patterns such as vandalism and other criminal activities.
- c. Neighborhood attitudes about the project that is about to be designed and built on our site.
- d. Neighborhood attitudes about what is positive and what is negative in the neighborhood.

- e. Relative permanence of the neighborhood population.
- f. Neighborhood trends in terms of all the factors mentioned above.

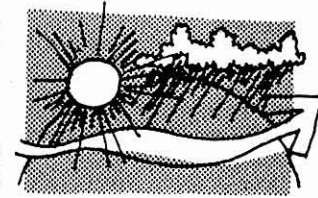

#### 11. Climate

- a. Temperature variation over the months of the year including the maximum highs and lows and the maximum and average day-night temperature swing for the days of each month.
- b. Humidity variation over the months of the year including maximums, minimums, and averages for each month and for a typical day of each month.
- c. Rainfall variation over the months of the year in inches. Should include the maximum rainfall that can be expected in any one day.
- d. Snowfall variation over the months of the year in inches. Should include the maximum snowfall that can be expected in any one day.
- e. Prevailing wind directions for the months of the year including velocity in feet per minute or miles per hour and variations that can be expected over the course of the day and night. Should also include the maximum wind velocity that can be expected.
- f. Sun path at the summer and winter solstice (high point and low point) including altitude and azimuth at particular times of the day for summer and winter (sunrise and sunset, position at 9 a.m., noon and 3 p.m.).
- g. Energy related data such as degree

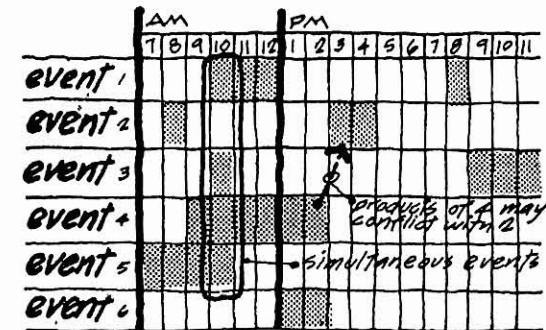
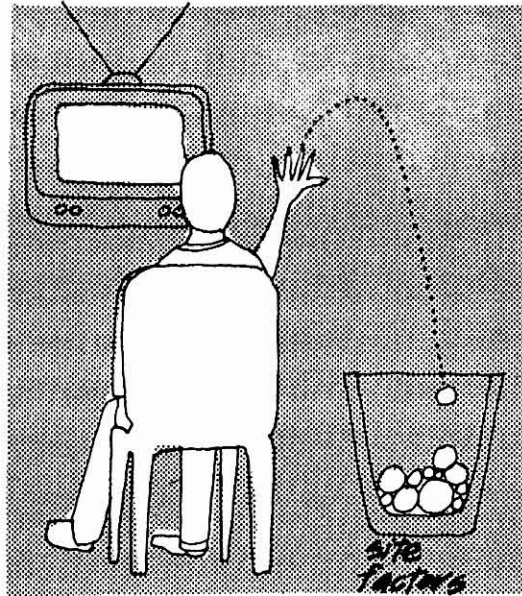

days or BTU's of sunlight falling on our site.

- h. Potential natural catastrophes such as earthquakes, hurricanes and tornados. May include documentation of earthquake zone that our site lies within and history of natural catastrophes in the area.

Depending on our particular project, some of these issues will be more important than others. Some analysis categories may drop out completely and new ones may be required.

It is important to avoid being so concerned about the "legalities" of the classification system that we lose sight of the meaning and importance of site analysis. It is not as important how the site facts are classified as that they are adequately covered somewhere in our analysis.

There is always a danger inherent in any checklist. Checklists make it easy for us to mentally disengage from the task at hand and sometimes give us a feeling of false security. We feel that if we simply "put something" under each heading we will have fulfilled our responsibility to analyze the site. We cannot allow our site analysis to become a mindless filling of "data bins."

We must remain mentally engaged with the process, thinking of the implications of the facts as we find them, analyzing issues and sub-issues until we are satisfied that we have gotten "to the bottom" of them. We must follow what may at first seem tangent concerns until we establish that they are irrelevant or that they do indeed contain some valuable information. We must not allow the implied segregation of data on the checklist to inhibit an understanding of the linkages between our site conditions. It is of value, for example, to juxtapose all the issues dealing with time or schedule on the time frame of a typical day and for different times of the year. This allows us to see the ebb and flow of the site forces in concert rather than in isolation. It also permits us to feel the composite of the forces on the site in a way that approximates reality.

## COLLECTING THE DATA

Once the information needed has been identified, we must outline the sources of the data and collect it. In some cases this information must come from others, while in other cases we may gather it directly ourselves.

Sources of information may vary from city to city and from site to site. It is important to keep in mind that for some types of data a single source will suffice. This is true primarily for quantitative or technical information. Other types of data, principally the qualitative type, may require several sources for purposes of verification. An outline of potential information sources follows.

### 1. Location

State maps may be miniaturized with only major highways and cities shown. City maps of a reasonable size can be found in most telephone books. We only need to relate our site to major streets or landmarks. It may be helpful to purchase an aerial photograph of our site and neighborhood from an aerial survey company. These can be produced at different scales and allow us to trace the neighborhood streets and facilities from the photo. We may trace the neighborhood context from a zoning map which can be found in the municipal planning department or obtained from local blueprinting companies. Documentation of the distances and travel times must be done by actually driving them or, in the case of pedestrian circulation, by walking them.

	data	data	data	data	data	data	data	data	data	data	data	data	data	data	data	data	data	data	data	data
SOURCE 1			●				●				●									●
SOURCE 2	●					●								●						
SOURCE 3				●				●		●									●	
SOURCE 4		●		●					●						●	●				
SOURCE 5				●	●						●								●	
SOURCE 6	●						●													●
SOURCE 7				●													●			

## 2. Neighborhood Context

Zoning for our site and neighborhood can be learned at the municipal planning department or at local printing companies that have the zoning maps on file. Learning about zoning trends may involve conversations with real estate agents who work in the area and municipal planners. We must directly observe the existing building and exterior space uses while talking to area businessmen and residents, real estate agents and municipal planners about projected uses. Several other issues require direct observation. These include architectural patterns, solid-void relationships, significant buildings, fragile situations, street lighting, and the condition of the buildings. The municipal planning department should be consulted about the existence and requirements of any special neighborhood classifications such as "historic district." Sun and shade patterns at different times of the year involve documentation of the building and landscaping areas and heights and the shadow patterns at typical times of the day (9 a.m., noon, 3 p.m.) at the summer and winter solstice and perhaps at the equinoxes. Building heights and areas must be estimated by direct observation with perhaps the aid of photography. Sun azimuth (horizontal angle) and altitude (vertical angle) can be collected from *Architectural Graphic Standards*, other standard references or the local weather bureau. The local transportation or traffic plan-

ning department should have information on existing and projected traffic around the site. Particular routes of specific vehicular types (trash, busses, fire trucks) must be collected from each company or agency. Major drainage patterns can be interpolated from U.S. Geological Survey Maps. These can usually be purchased at local printing companies, from the Geological Survey district office or the city engineer.

## 3. Size and Zoning

Much of the information under Size and Zoning, Legal, Natural Physical Features and Man-made Features would be collected and documented by a survey engineer if we were to have a topographic survey done for our site. These surveys can be tailored to include more or less of our site data list depending upon how much of the research we are able to do ourselves and how much our client is able to pay for the survey. (Typically, clients are responsible for providing the site survey information to the architect.) For our purposes, we will assume that we must collect all the data.

Site boundary dimensions must be measured directly to be verified but can be obtained in recorded form from title insurance companies or the county tax assessor's office. Present and future street rights of way can usually be obtained from the municipal transportation department while easements involve contacting all the utility companies. All the zoning in-

formation including classification, setbacks, height restrictions, allowable site coverage, allowable uses and parking requirements involve first finding out what the present zoning classification is. This may be done by obtaining a zoning map from a local printing company or city planning department. The specific information about what our site zone classification allows can be collected from the municipal zoning ordinance, a book which documents this information for each zone classification. A copy of the ordinance may be purchased from municipal planning or borrowed from the library. Conflicts between what our site zone allows and what our client wants to put on the site must be determined by comparison. If there is a conflict, the client must either apply for a variance to the municipal board of adjustment or apply for a different zoning classification that does allow all the planned uses on the site. He may also purchase additional property or purchase a different piece of property. Another option is to simply amend the planned uses to fit those that are allowed. The number of square feet of buildable area is calculated by taking the area inside the site boundary lines and subtracting the area of any setbacks or easements. Normally, parking and on site roads may occupy the unbuildable area inside setbacks.

## 4. Legal

Most of the legal information about the site including the legal description,



covenants and restrictions and property owner can be obtained from the deed to the property. The owner or the title insurance company should have this information. The county tax assessor's office may have some or all of it as well. Jurisdiction is normally a matter of finding out whether the site is inside or outside of the city limits. Sometimes there may be special jurisdictional issues such as those regarding Indian reservation land or federal or state land. Projected changes in this information require conversations with our client, the appropriate jurisdictional agencies, neighborhood associations, previous owners or whatever parties are responsible for the covenants and restrictions.

#### 5. Natural Physical Features

The majority of the information in this category requires direct observation of the site and recording the data over a topographic survey showing site contours.

Topographic contours are included in the property survey done by the survey engineer. Depending on how contoured our site is, the intervals may range from one foot to ten feet. On very large sites the intervals may be even more. Where we must determine the contours, we conduct the topographic survey ourselves. Where we are interested only in a general feeling about the slope of the site we may do so by standing at the four corners of the property (where the site size permits)

and estimating the elevations of the other corners in relation to our eye level. Once we establish the overall fall of the site then we can estimate the rate of fall (contour intervals) between the high points and low points.

If we require a more accurate record of the site contours, we must conduct a formal topographic survey.

Major topographic features such as high points, low points, ridges, valleys, sloped and flat areas involve direct observation and recording the information on the contour map.

Drainage patterns also involve direct observation. Drainage patterns will always be perpendicular to the site contour lines. In addition, we should look for major and minor drainage collectors in the valleys of the site. These should be documented in terms of patterns onto our site and off our site.

Permanent bodies of standing or moving water should be recorded over the contour map. The edge of this water will obviously be one of the contour lines and one of the low edges of the site.

Existing natural features on the site including trees, ground cover, rock outcroppings, ground surface texture and mounds all require direct observation and recording over the contour map. Where precise location of these is important we should measure their position in relation to some site reference point and record these dimensions on

our map.

Opinions and judgments about the value of natural site features may be recorded in the form of notes around the map where the features are recorded. These also involve looking ahead to the project in deciding about the appropriateness and value of the features to our design situation.

Soil conditions require soil borings and a soils report which describes soil type and bearing capacity. Sometimes the soils test is not done until after schematic design so that only the soil in the area where the building will be located is tested. This is especially true for large sites where only a small percentage of the land will be developed. Soils tests are normally paid for by the client and are conducted by a soils engineer or a testing laboratory.

#### 6. Man-made Features

On site features are normally included in the topographic survey done by the survey engineer. These would include such items as buildings, walls, retaining walls, ramadas, fences, playfields and courts, patios, plazas, drives, walls, service areas, curb cuts, power poles, hydrants and bus stop shelters. The size and location of these features must be directly measured on site and referenced to some bench mark element on the site. Where exact location is not crucial, their size and location may be estimated from an aerial photograph of the site. These may normally be obtained from a local aerial survey

company or from the municipal planning department.

Where the internal layout of existing buildings is important it is best if we can obtain a set of the original working drawings. If these are not available we may need to actually measure the building and reconstruct the layout drawing.

Documentation of architectural character of buildings surrounding our site can be done by sketching or photography together with notes that record our observations and judgments. It may be beneficial, for example, to draw the street facades of a set of historic structures for several blocks to record the overall image, formal variations, rhythm and frequency of forms and details. There may also be reports already done about historic areas which document much of this data for us. The municipal planning department should know if such reports exist.

#### Circulation

Documentation of all streets, roads, alleys, paths, sidewalks, plazas, etc., will probably already have been done under previous site data categories. "Circulation" primarily addresses what happens on those path systems.

Data concerning the pedestrian network both on and off site may involve direct observation, projections based on neighborhood magnets (grocery stores, etc.) and possibly studies done by municipal planning (downtown pedestrian traffic, etc.). We may also learn

a great deal about the movement patterns by talking with neighborhood residents. We are interested in who circulates, why they circulate, when they circulate, how many of them circulate, where their traffic originates and where it terminates.

Ideas concerning the ways that existing pedestrian traffic could be reinforced or facilitated begin to enter the realm of site design. These concepts should be documented on separate diagrams using the existing patterns as an initial graphic framework.

Vehicular traffic on our site, adjacent to it or in the neighborhood may be researched by direct observation, projections based on magnets and/or previous studies done by municipal planning or transportation (street load patterns, etc.).

Adjacent and nearby parking requires direct observation. Where the situation is particularly complicated we may start our analysis with an aerial photograph.

Public transportation routes in relation to our site may be obtained from route maps secured at the department of public transportation. This should also include direct observation for the specific locations of stops and shelters that occur on or near our site.

Directions and paths of arrival and dispersal of the users of our building (including the modes of arrival and dispersal) may sometimes be projected by

studying the type of building, the location of our site in relation to the rest of the city and the major street system. The characteristics of the users (staff, customers, residents, etc.), time of arrival and departure and probable general approach and departure directions should be documented.

Specific locations or edges on our site that offer the safest and most convenient pedestrian and vehicular access to and egress from our site can be projected by considering all the circulation data. This begins to enter the realm of design decision but nevertheless is a valuable judgment to record in our contextual analysis.

Travel times must be studied by direct observation. We must walk the site and record the time it takes to cross it. We must drive from our site to the related locations in the city and record the travel times.

#### 8. Utilities

Documentation of all utility information can be done by visiting the respective utility departments and companies. Often these companies can give us a print of a drawing which already records the needed information. We need to verify with each utility that these drawings are current and accurate.

Recording the best connection opportunities requires an analysis of the utility data in relation to the conditions on our site (distances to probable building

sites, relation to contours, barriers, soil conditions, etc.).

#### 9. Sensory

All information about views on and around our site requires direct observation. We may use photographs and sketches to assist in this regard.

Noise data can be collected by direct experience on the site with the use of sensing equipment and by studying noise related data in other information categories (traffic, surrounding uses, etc.). It is important to document noise in terms of intensity, source, duration, schedule and direction.

Odors, smoke and other pollutants require direct observation and experience on the site. Where pollution is large in scale, aerial photographs may help in studying source and direction. The direction of prevailing winds, how they change over the day, from day to night, etc. is also important.

#### 10. Human and Cultural

A considerable amount of data can be obtained from census statistics on the neighborhood. This information is usually available through the local municipal planning agency. It may be useful to discuss the human and cultural neighborhood factors with representatives of the neighborhood associations or with social service and recreational agencies, retail, religious and/or educational services that operate in or for the neighborhood population. In the absence of consolidated sources for

collecting this information, we may conduct interviews with a sample of the neighborhood residents although this is relatively inefficient and may not produce a real consensus of the neighborhood value system.

Human and cultural considerations can extend beyond the immediate site to political processes, city wide issues regarding the project and similar factors. The inclusion or exclusion of these issues in our contextual analysis depends on our view of the meaning of "project context."

#### 11. Climate

All climate data is usually available from the local weather service. There are also weather profiles for different locations which are published by the armed services and by universities. It is advantageous to interview appropriate people about weather trends in an area. These individuals may work at the weather bureau, university, airport or armed service base.

The analysis of all eleven data classifications should include future projections to the extent that they can be made.

## MAKING THE DIAGRAMS

It is generally useful to diagram the site information as we collect it. Whether we refine the diagrammatic forms to a more presentation oriented degree of finish depends on how the diagrams will be used and to whom we will show them. We will assume here that the diagrams require refinement.

## DIAGRAMMATIC FRAMEWORK

As previously discussed, there are at least two ways of approaching the diagramming of contextual information. One involves an integration of the diagrams into one composite graphic form. The other separates each contextual fact onto a separate diagram.

**The composite or integrated approach attempts to state all the site data on one drawing to emphasize the total situation and to sensitize us to the relationships between contextual factors.**

This drawing is normally relatively large in scale to avoid graphic clutter. The potential difficulty with the drawing is that it may become too complex and confusing. This is particularly true for a complex site. When we approach our contextual analysis in this way we should be sure to maintain a sense of clarity and hierarchy in our graphics to ensure that the major site issues are given the major graphic emphasis in the diagrams.

**The separated or segregated approach records the site information separately**

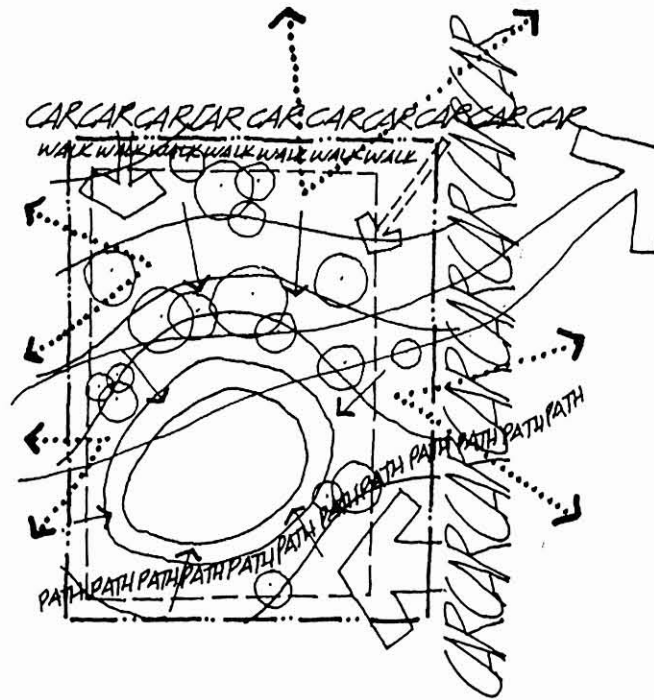
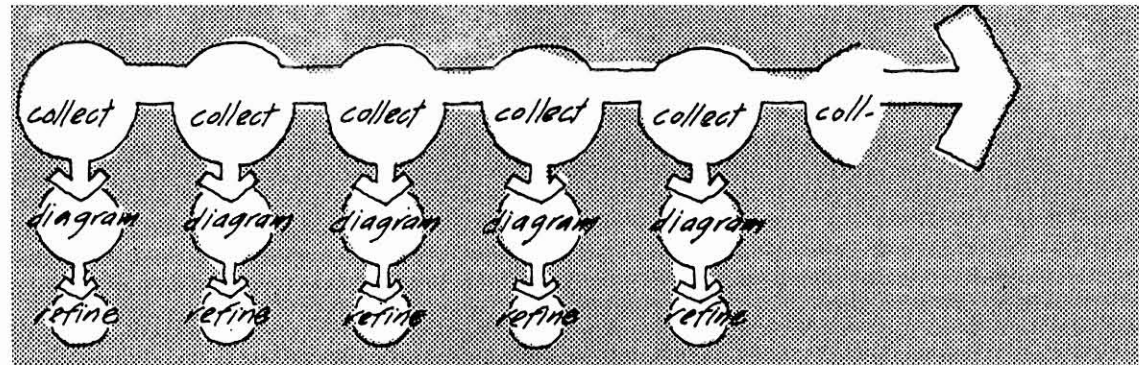

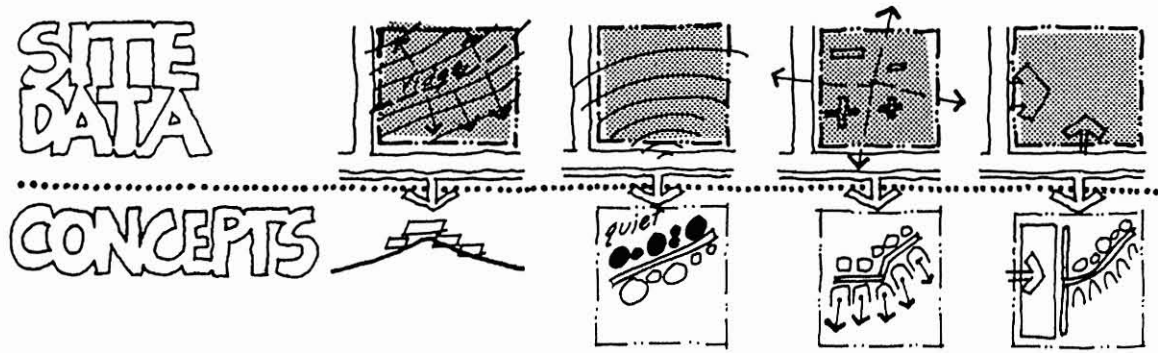

over simplified referent drawings of the site. The referent drawing is repeated as many times as we have data to present.

This more "itemized" approach helps us to avoid overlooking a site factor. Further, it allows each piece of contextual data a clear uncluttered expression. Because each diagram has its own referent drawing we have the flexibility of shifting the referent from plan to perspective to section or elevation depending on the type of information being diagrammed. It permits us to think in terms of optimum site concept responses to each site factor when we begin schematic design. The potential difficulty with this technique is that a piecemeal approach to the graphic recording of data may foster a piecemeal approach to design. In deciding whether to diagram in the integrated or segregated mode we should think about how we design and which of these approaches fits most comfortably with the way we tend to conceptualize our project.

Because it more clearly illustrates the different ways to diagram site data we will use the segregated approach to discuss some techniques of contextual diagramming. Even if we eventually integrate these diagrams into one drawing, we may want to record the site data during collection separately because this allows us to use smaller, more convenient referent drawings during the on site analysis. These separate drawings require us to think about the logical sequence of the information and how one piece of information depends on others

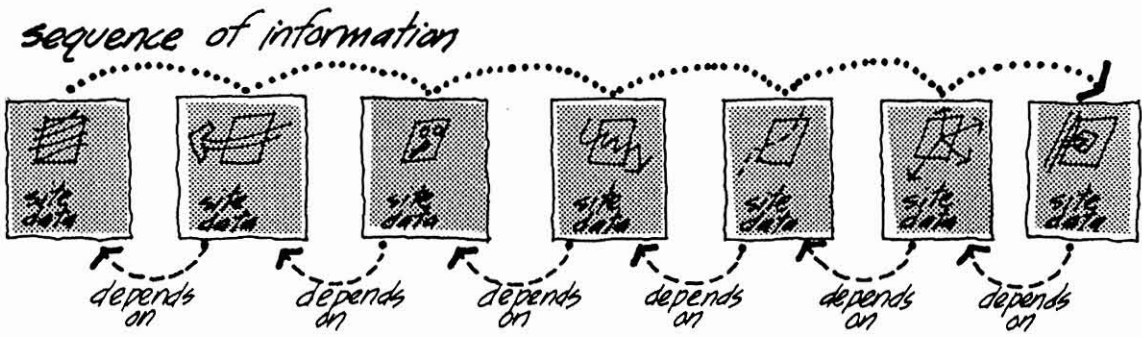

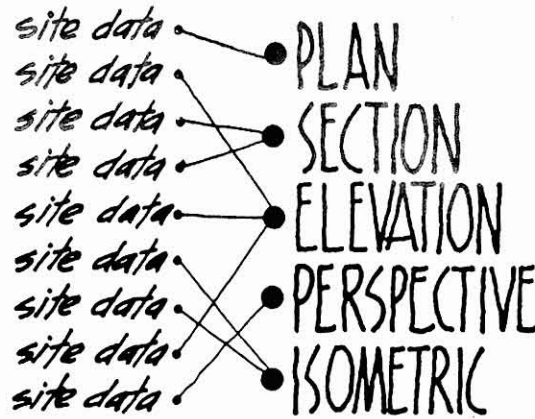

(drainage depends on contours, etc.).

As we will see, "purity" in the use of the integrated or the segregated approach is not an issue. We may separate data diagrammatically in the integrated approach and integrate certain data on a single referent drawing in the segregated approach.

## REFERENT DRAWINGS

The referent drawings over which we diagram the site issues may occur in several forms and at several scales. They will also contain different amounts of detail depending on the contextual information being addressed.

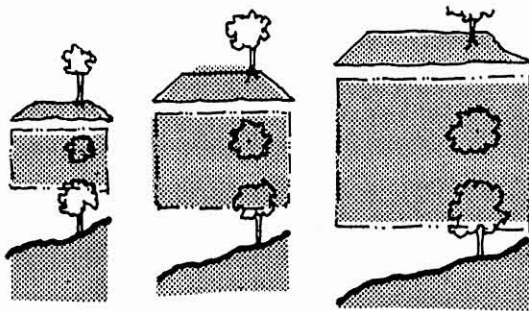

Referent drawings may be plans, sections, perspectives, isometrics or elevations. The choice of which of these to use relates to the type of data we are recording and how best to view it as a site force (top view, perspective view, etc.).

We may use any or all of these in the course of a contextual analysis. The sizes of the referent drawings depend on the complexity of the diagrams we will be making and the extent to which we may want to miniaturize the diagrams for convenience in data collection or for presentation.

Depending on how far reaching geographically a particular site factor is, our referent drawing will extend a greater or lesser distance beyond our actual site. If we are discussing neighborhood factors, the referent drawing may extend several blocks.

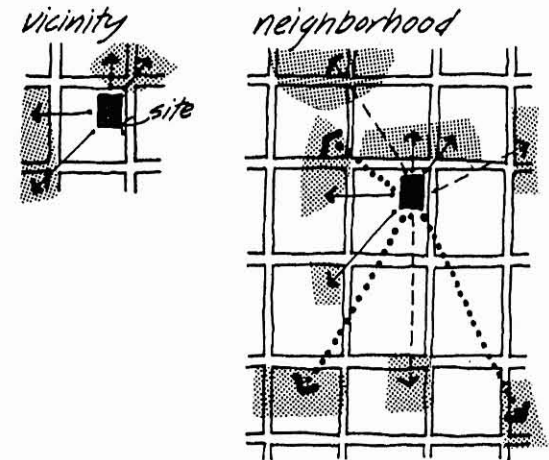

A large percentage of site data seems to be plan oriented. Normally, a typical referent drawing in plan will include the site boundaries and street pattern immediately adjacent to the site.

**We must be sure to make the referent drawing as simple as possible keeping in mind that the data to be recorded over it must be graphically bolder and more important than the referent information.**

If we are using line for the referent drawing the line weight should be very light. The referent must always be in the background graphically in our contextual analysis.

Once we have made one referent drawing it is useful to reproduce it by copy machine to avoid having to draw it multiple times. We are then ready to diagram the site issues.

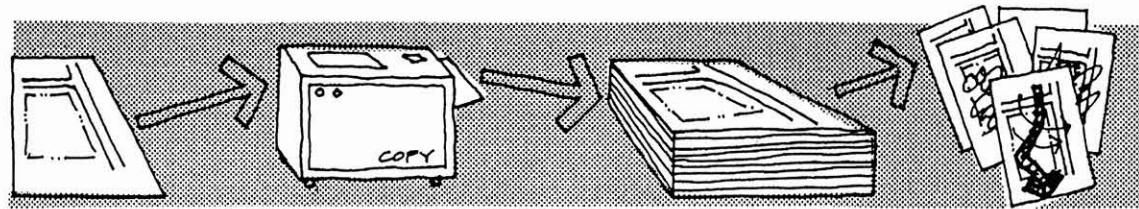
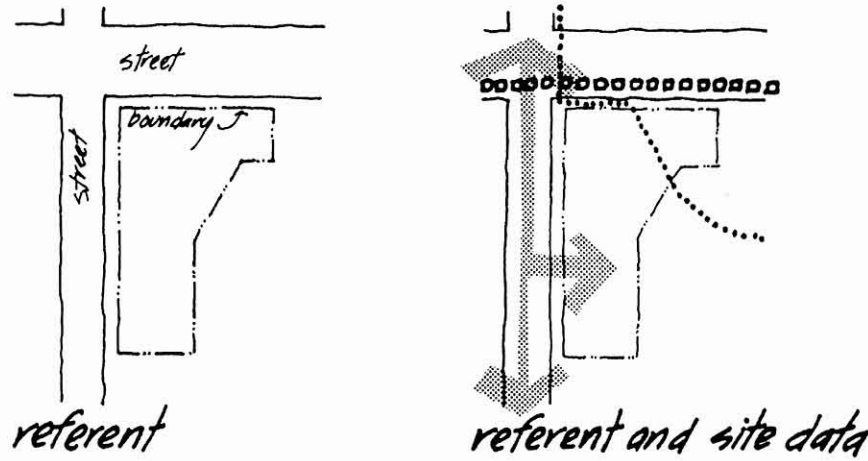

### DIAGRAMMATIC FORMS

The diagrammatic forms which are juxtaposed over the referent drawings may be representing physical things, qualities or conditions of physical things, actions and activities, patterns that are not immediately evident, temporal issues, human issues, etc. Our diagrammatic forms must be able to record and express both the visible and the invisible forces, pressures, problems, opportunities and mandates of the site.

We are also interested in diagramming future or potential contextual issues.



Some example diagrammatic forms are presented on the following pages using a fictitious site. The examples will show some typical ways of diagrammatically presenting site information and some varia-

tions and alternatives. We should keep in mind that there are many other graphic possibilities as well as opportunities to create combinations and syntheses of these diagramming examples.

# Contextual Analysis for a New Office Building, Tallahassee, Florida

## ● Project overview

This contextual analysis will serve as input for the design and construction of a new professional office building in Tallahassee, Florida. The new building will contain approximately 23,000 gross square feet of space and the site will accommodate approximately 115 cars.

## ● Site overview

The project site is in the southeast area of Tallahassee within an established neighborhood. The property is part of a square block office park (considerable cession restrictions) where all lots front a 6-acre pond in the center. Only 3 of the 10 office park lots have been built upon. The office park is bounded on 3 sides by existing and projected residential development and on the 4th side by a major arterial and commercial development.

The project property is a corner lot (NW corner of office park) bounded on the north and west by streets (moderate traffic) with an historic plantation home across the street intersection to the northwest. The lots to the east and south of the site have both been developed with office buildings.

The site is zoned B-1 and contains approximately 2.3 (250' x 420') heavily wooded acres. The land slopes from the northwest corner to the southeast corner (pond) with grades varying from flat to 13%. All required utilities are available. Both the sensory and human aspects of the site are positive.

## ● Climate overview

Tallahassee is located at latitude 30° 23' N and longitude 84° 22' W with an elevation of 55'. The climate is hot and humid.

Temperatures range from the 90's (F) in the summer to the 30's (and sometimes 20's) in the winter. Humidity remains high all year with peaks in the summer months (90%). Annual rainfall is about 60" with peaks in the spring and summer. Wind speed averages approximately 6 mph (open areas) from various prevailing directions.

Yearly cooling degree days outnumber heating degree days 2563 to 1563. Yearly skycover conditions involve an approximate 1/3-1/3-1/3 split between clear skies, partly cloudy skies and overcast skies. Fall is the peak clear sky period.

## ● Contents

Location - 45
Neighborhood - 49
Context
Size and Zoning - 70
Legal - 77
Natural Physical - 79
Features
Man-made - 87
Features
Circulation - 89
Utilities - 91
Sensory - 93
Human and Cultural - 100
Climate - 103



# Location

● Location of the city in the state or region

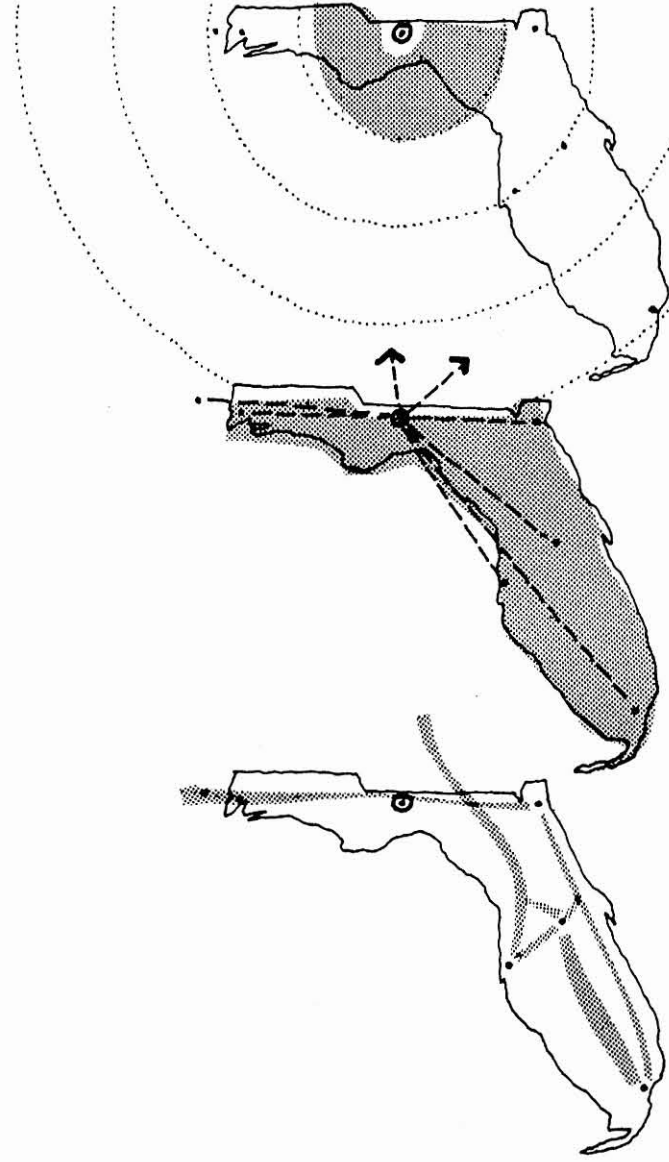
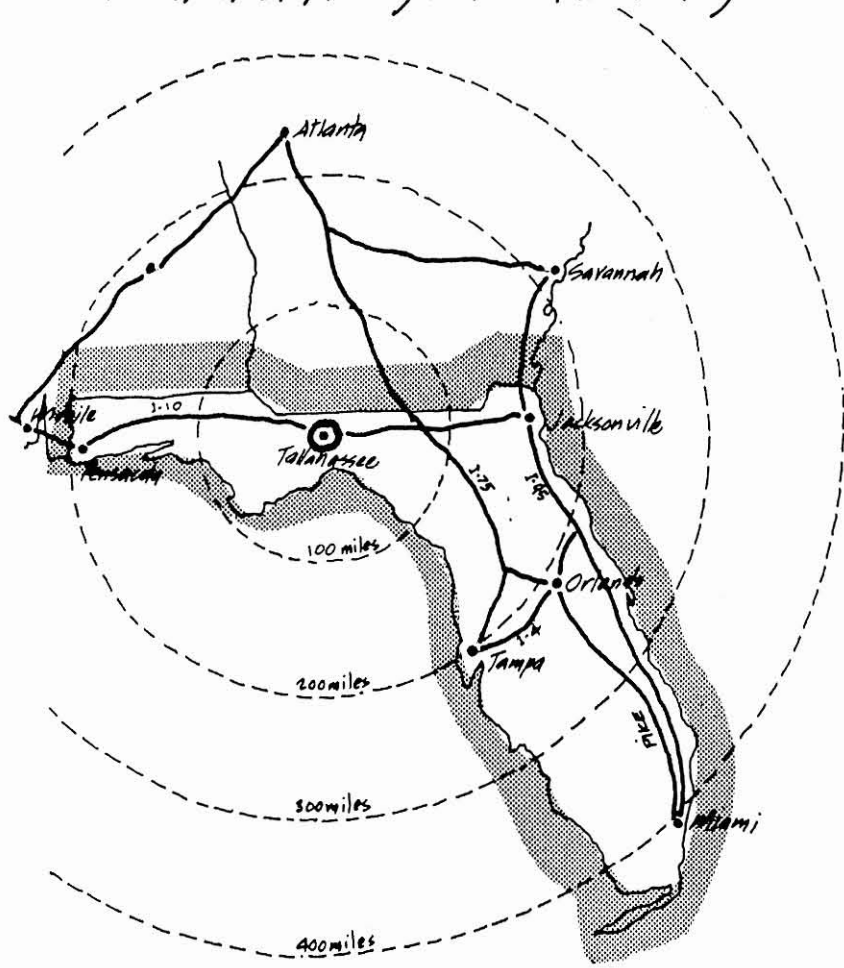

● Location of the neighborhood in the city

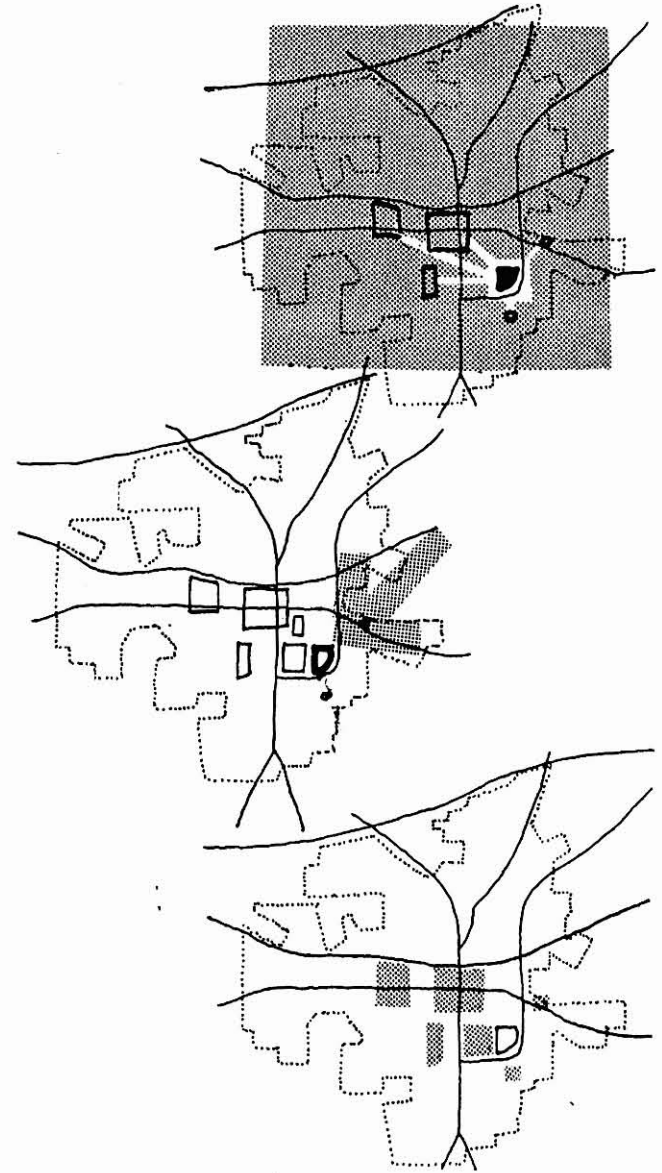
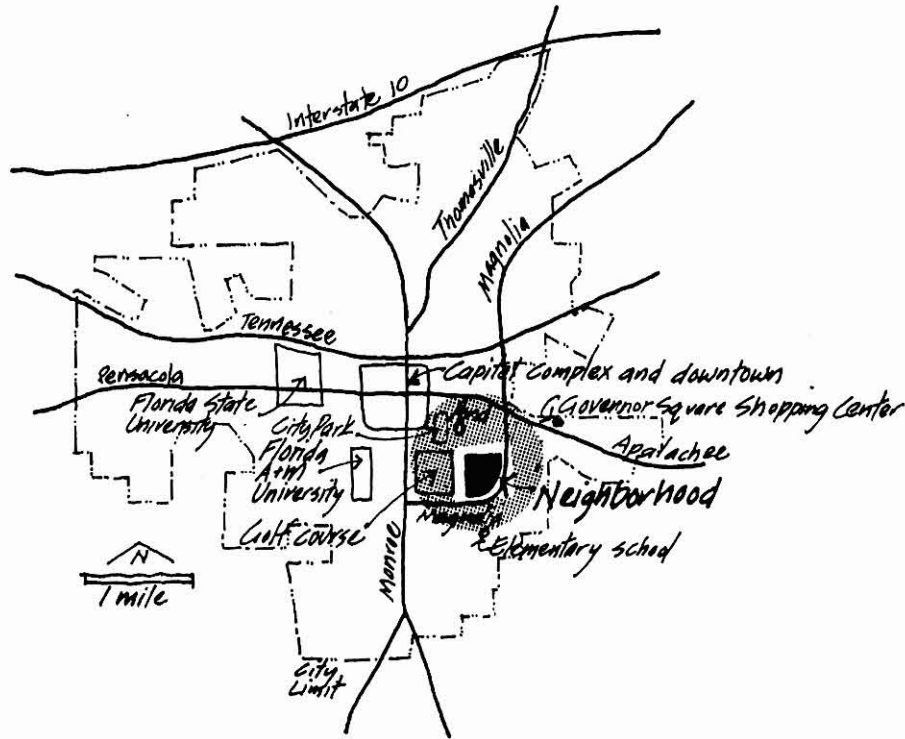

● Distances and travel times between site and related locations

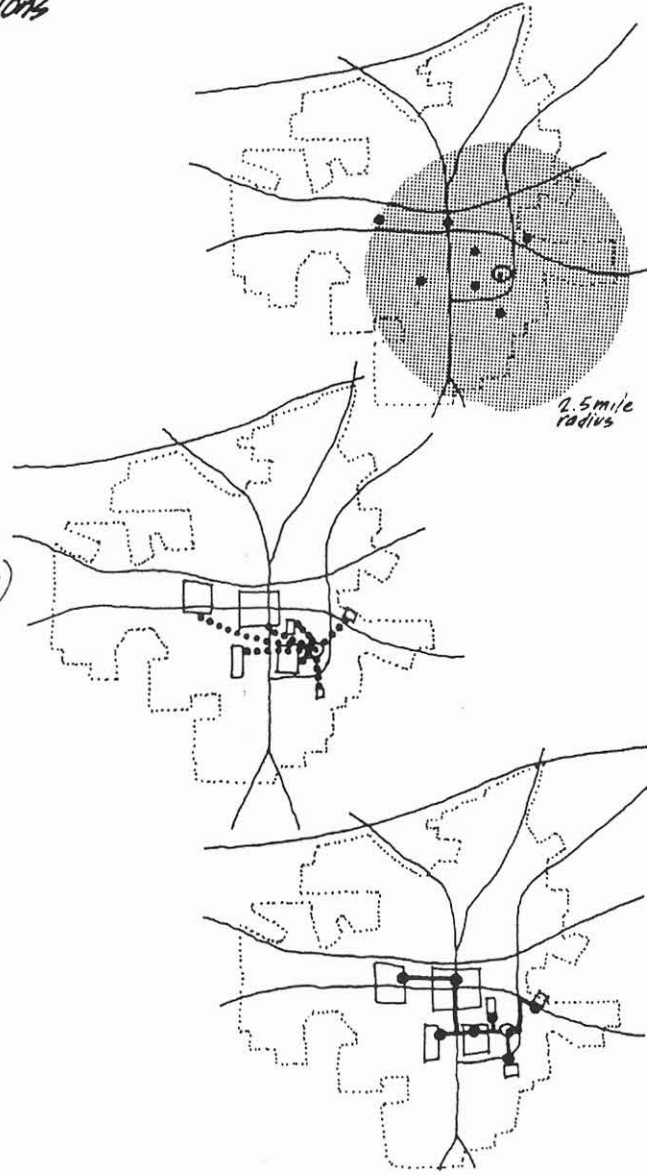
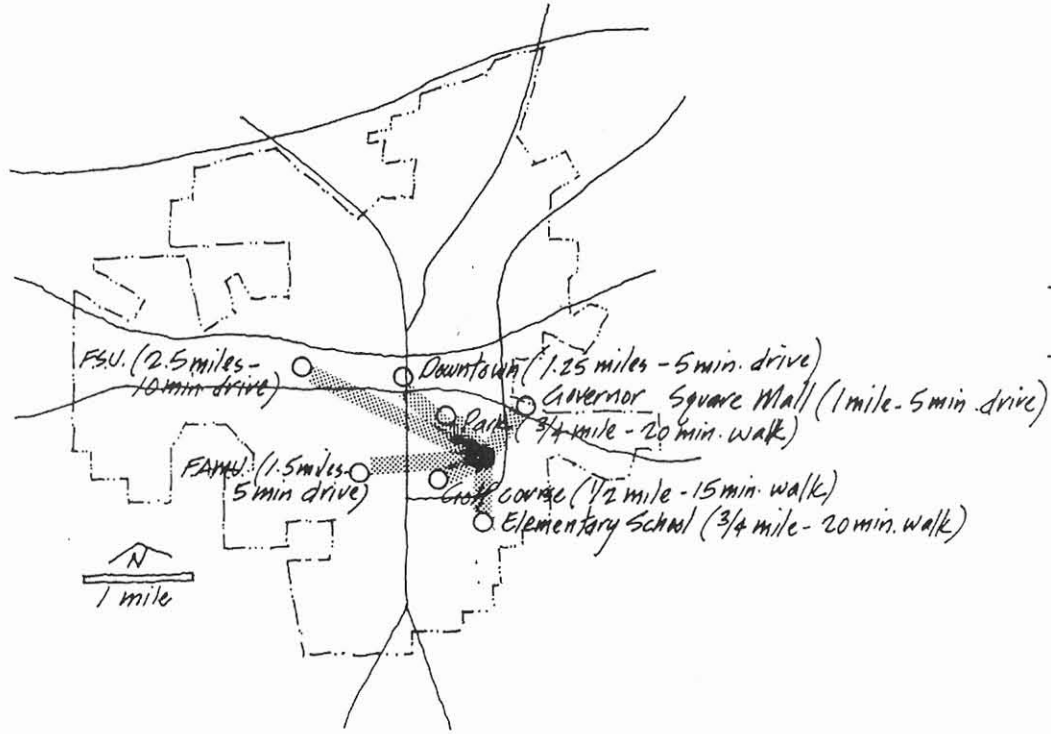

● Location of the site in the neighborhood

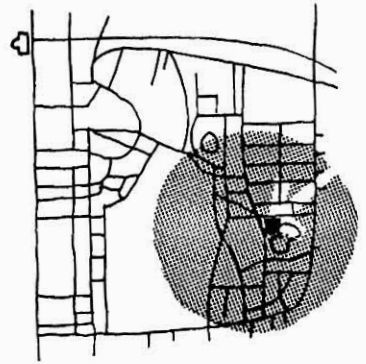
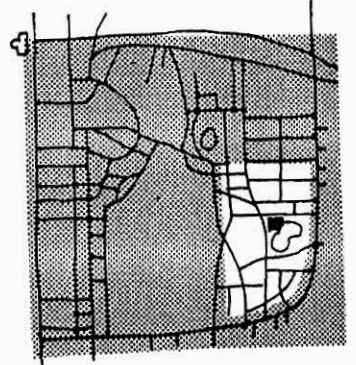
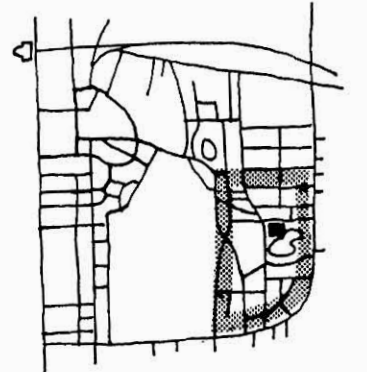
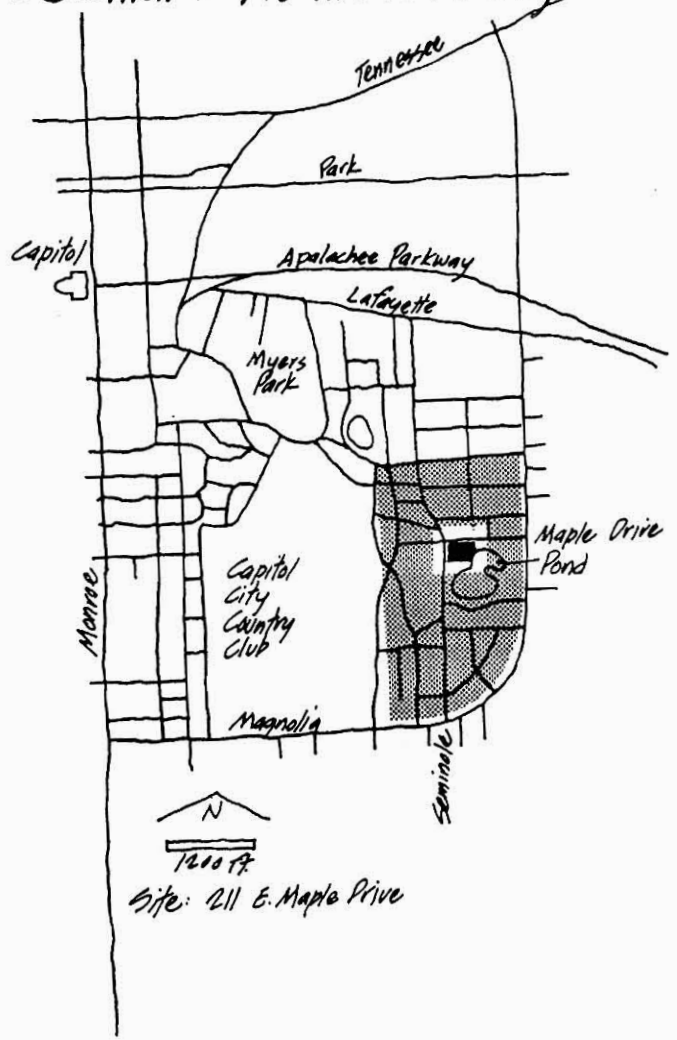

# Neighborhood Context

● Existing zoning (see City of Tallahassee Zoning Ordinance for details)

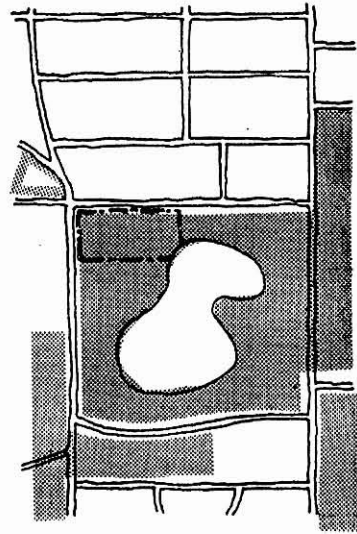
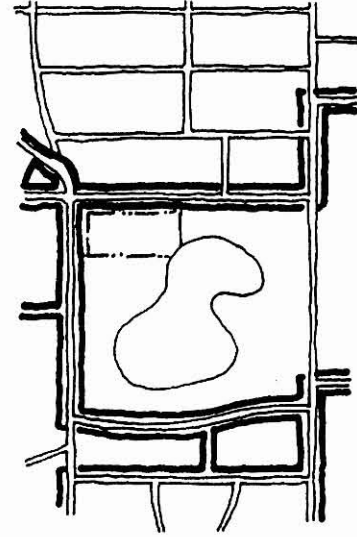
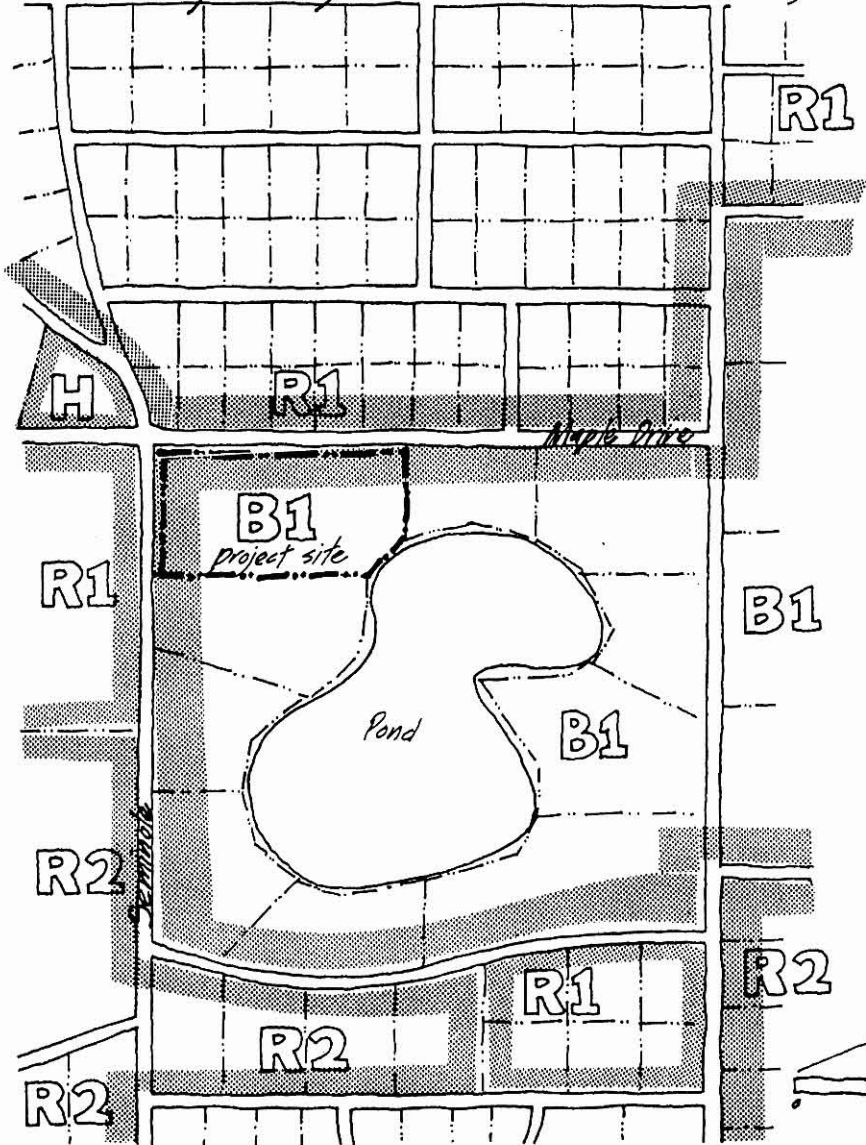

● *Projected future zoning*

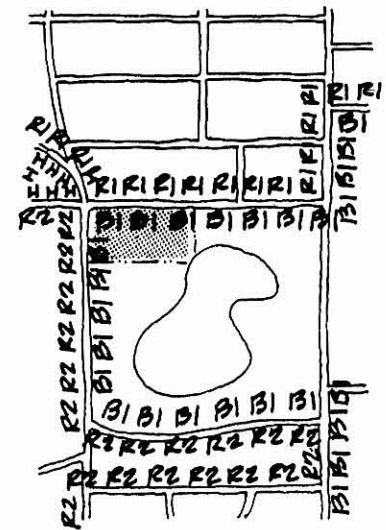
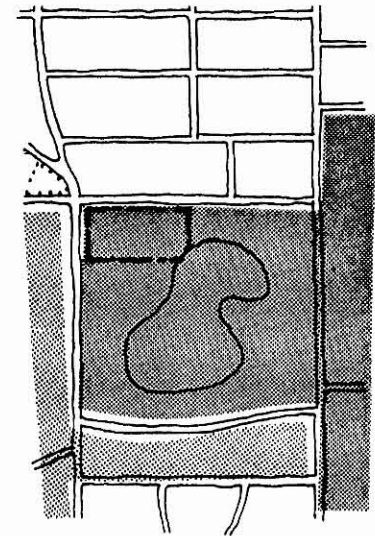
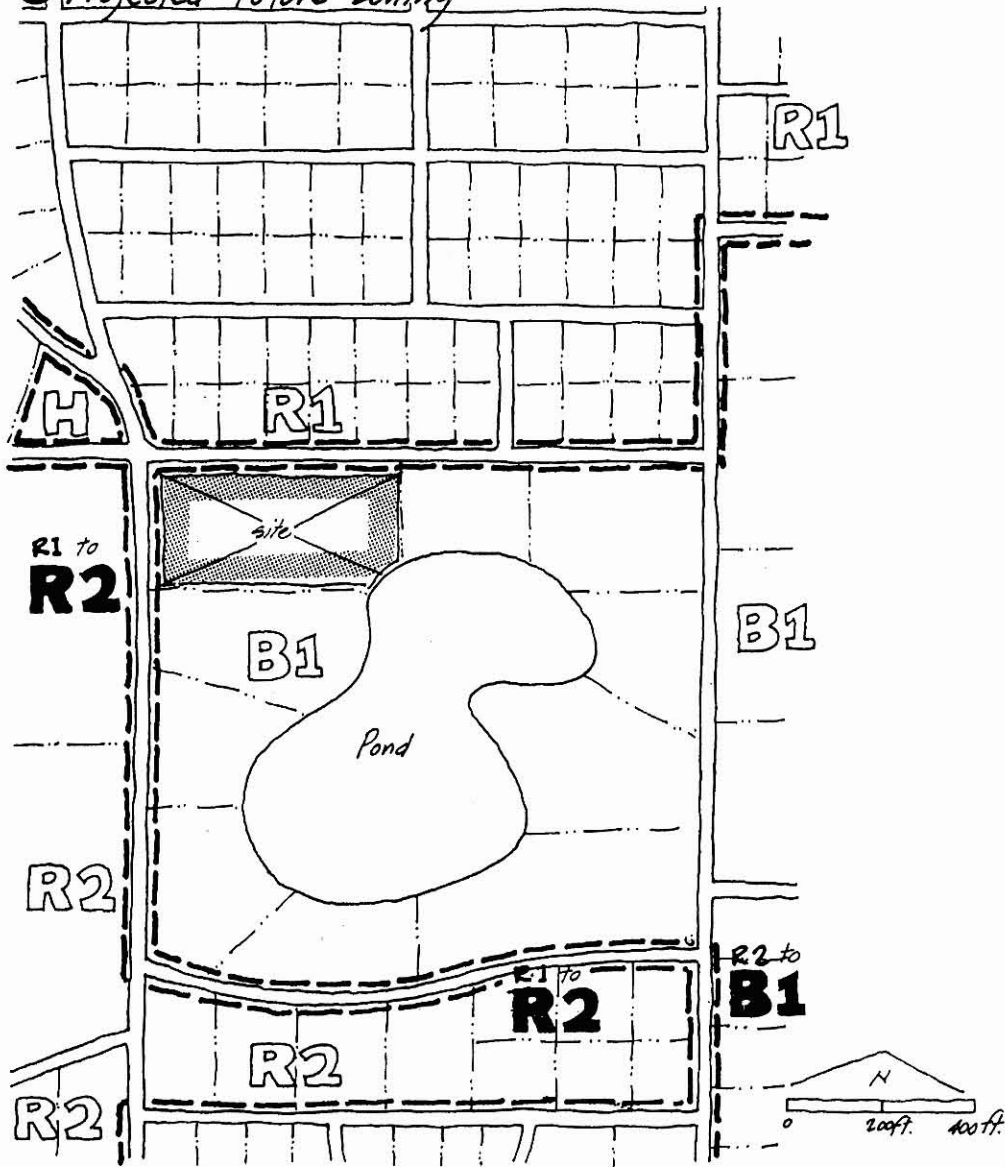

● Existing uses

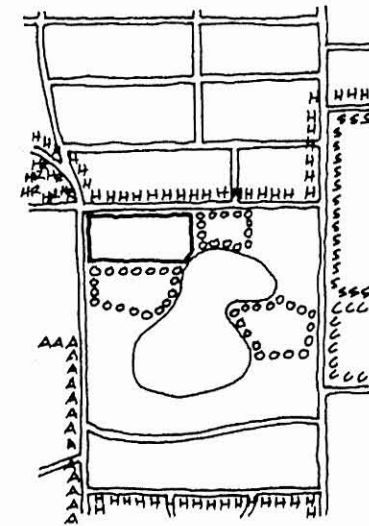
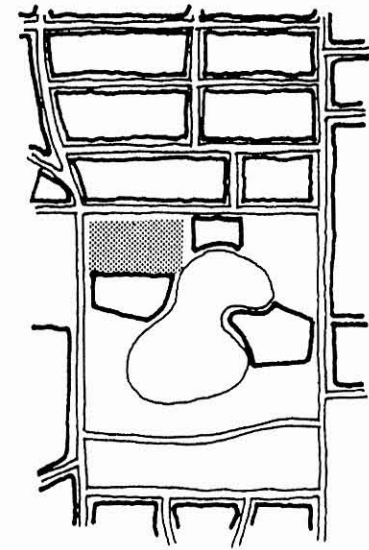
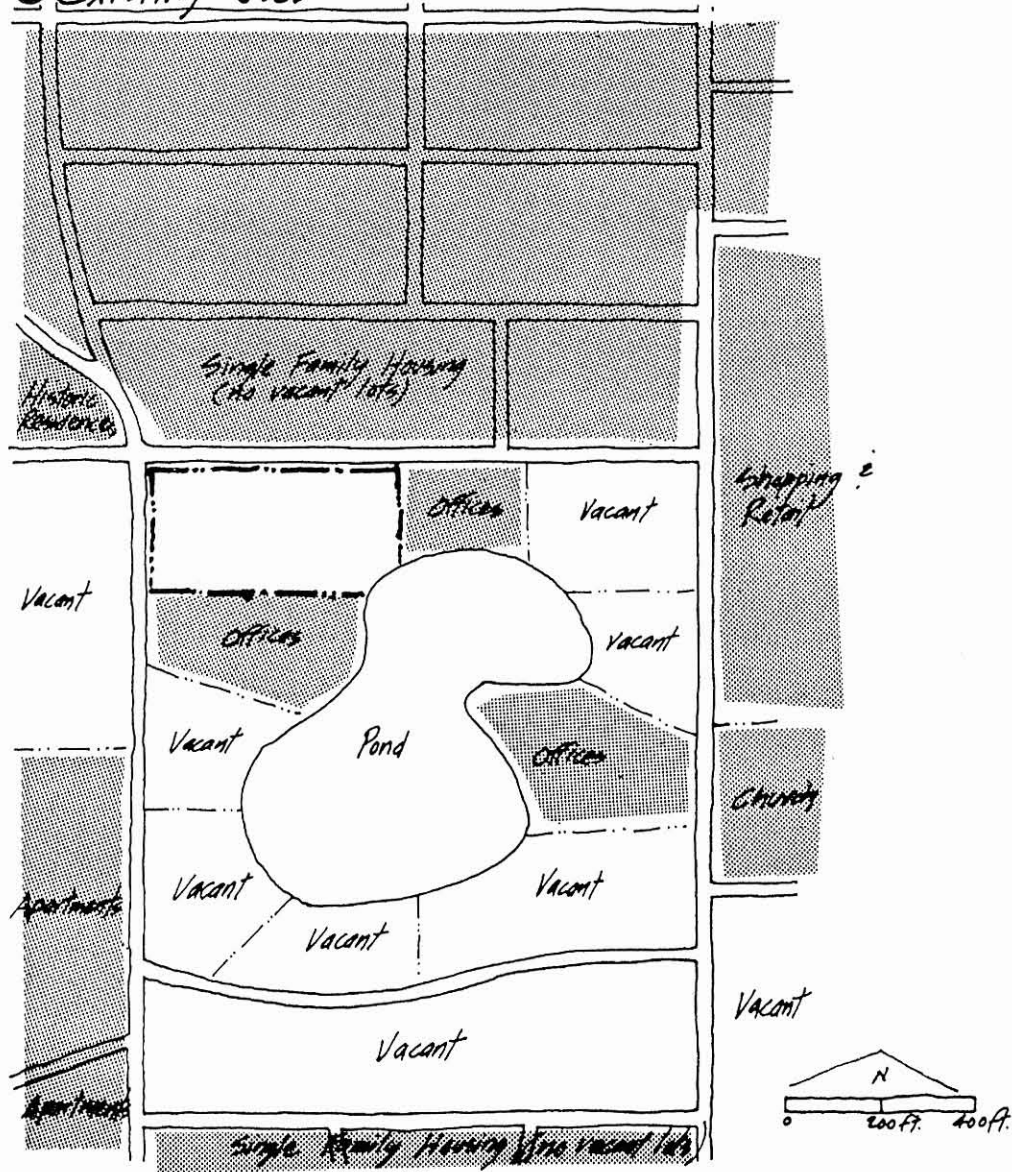

# ● Projected future uses

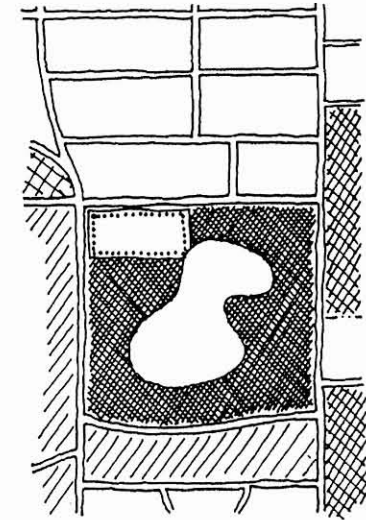
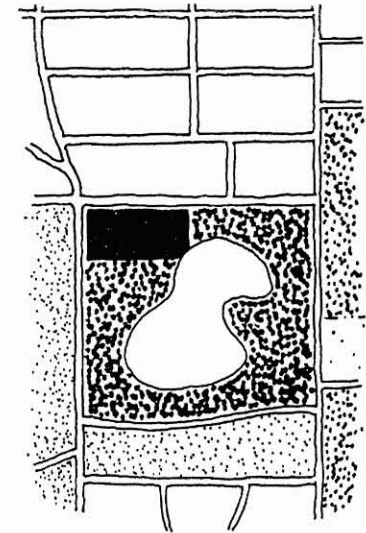
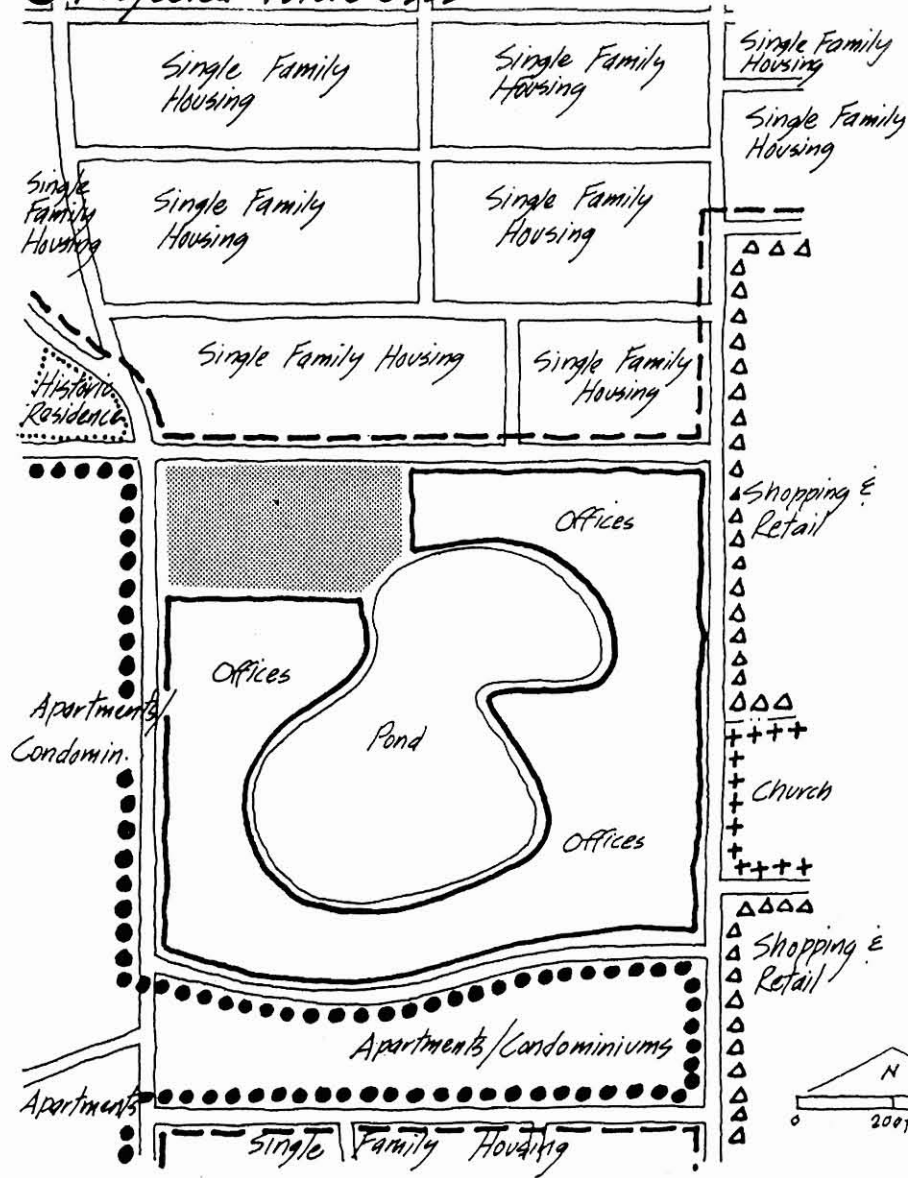



# ● Age or condition of existing buildings

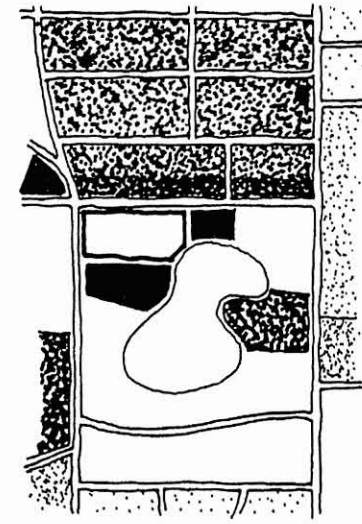
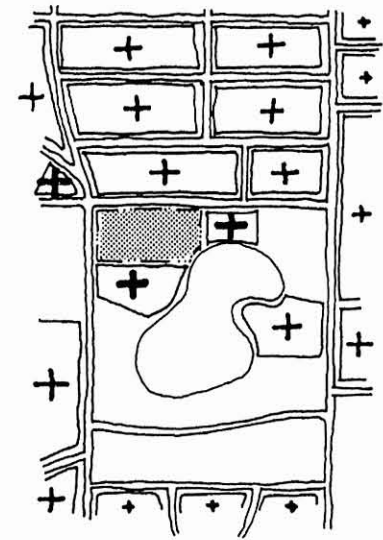
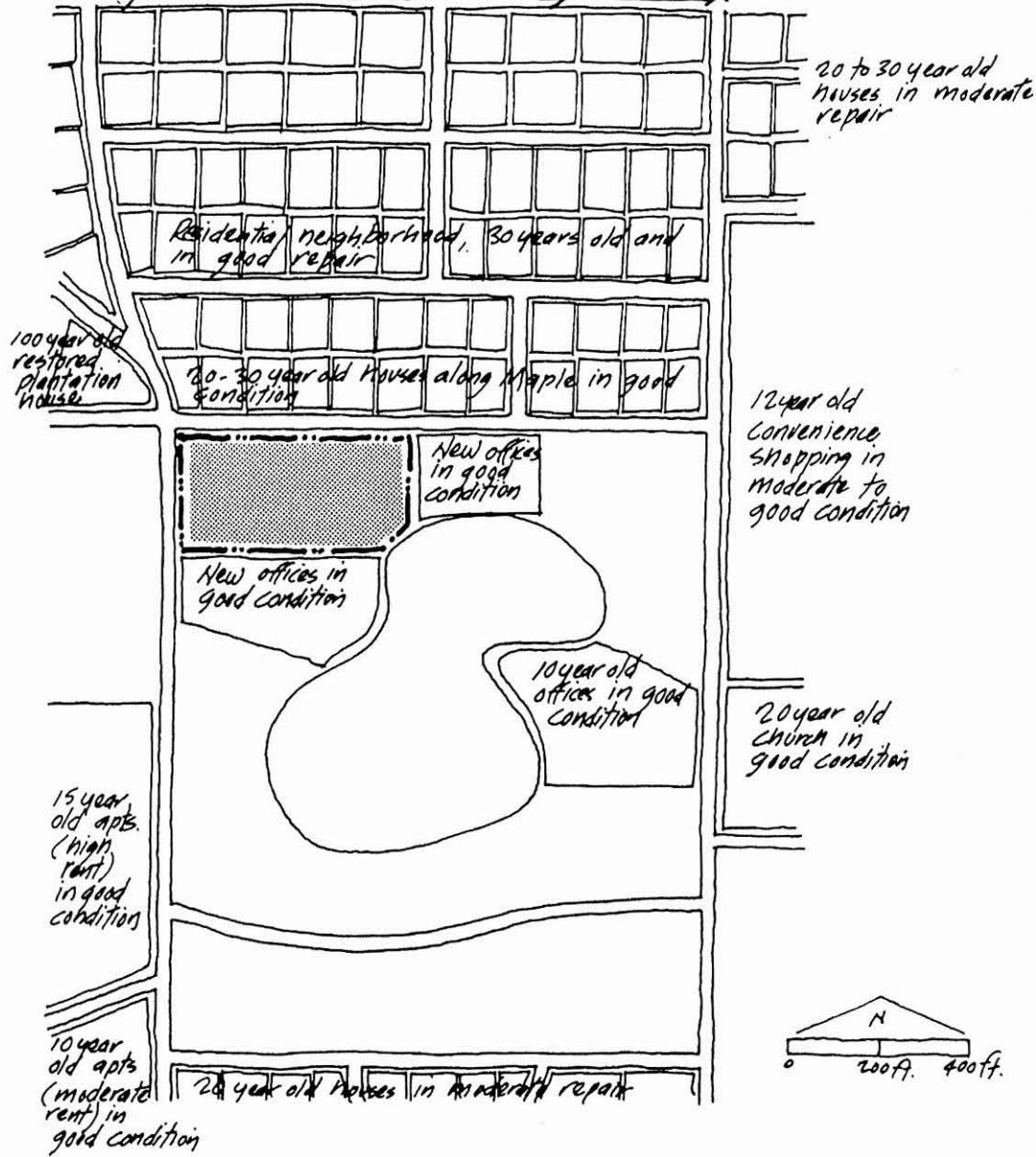

● Existing use of exterior space

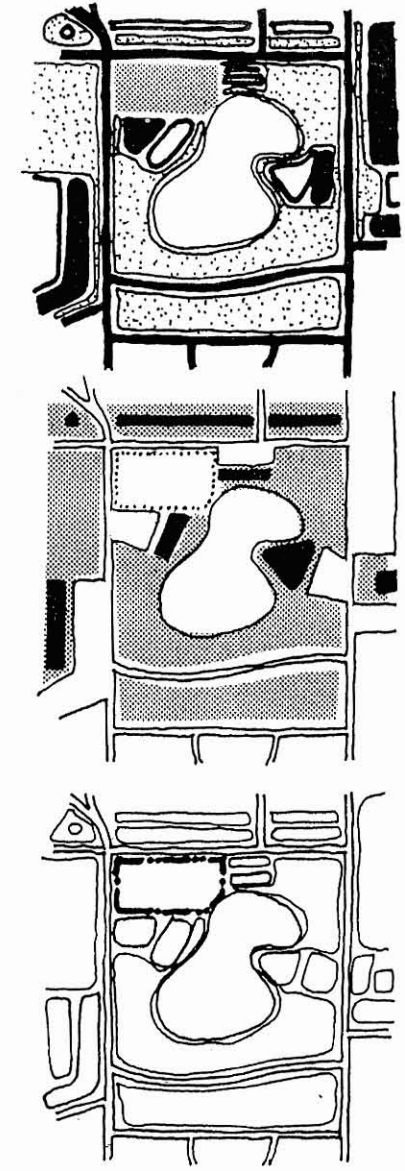
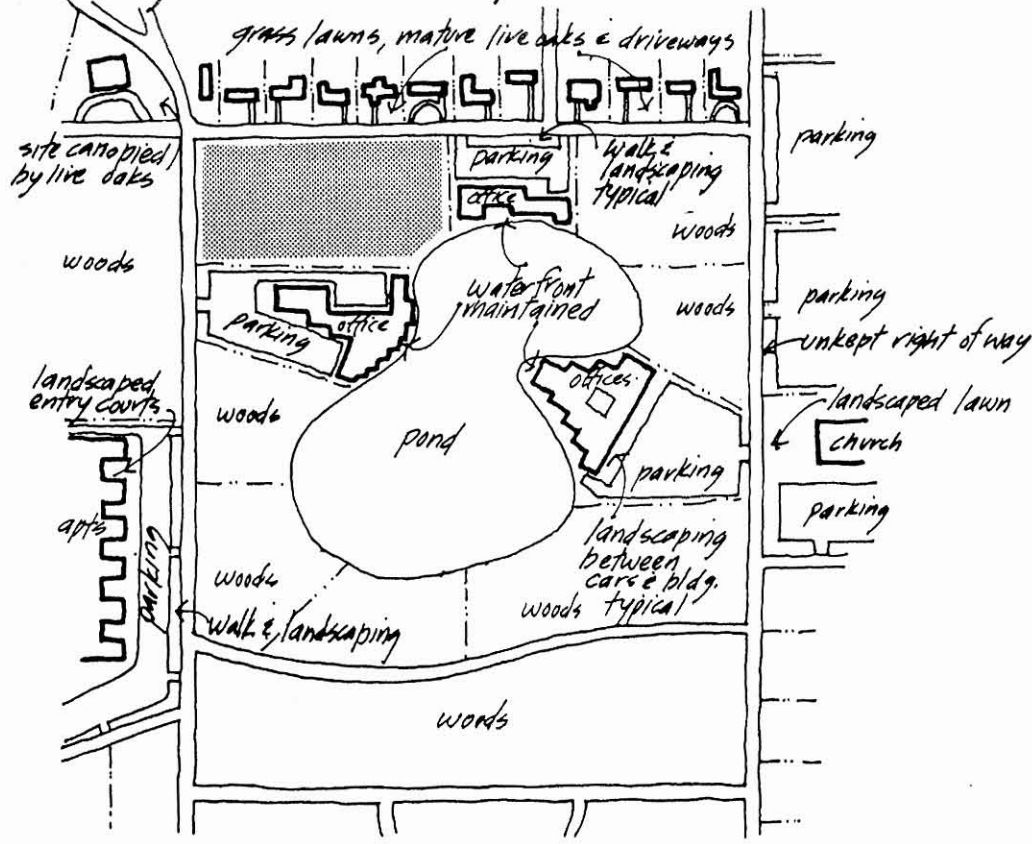

● Projected future use of exterior space

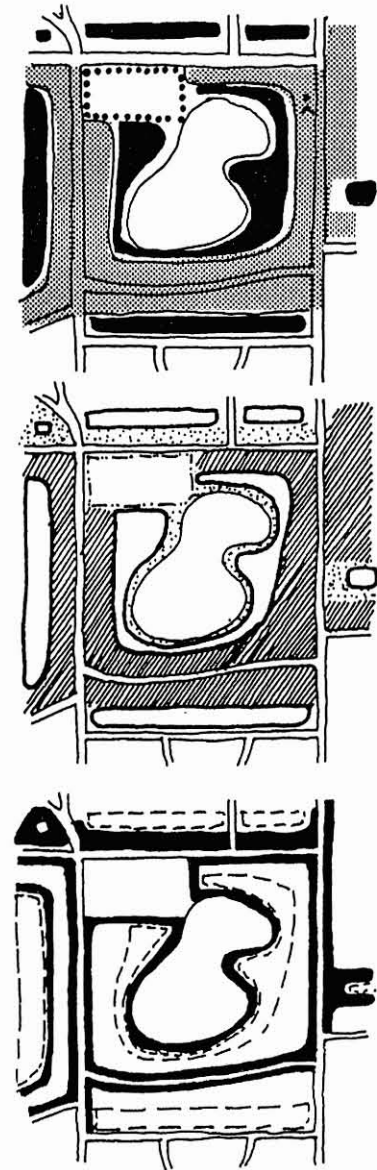
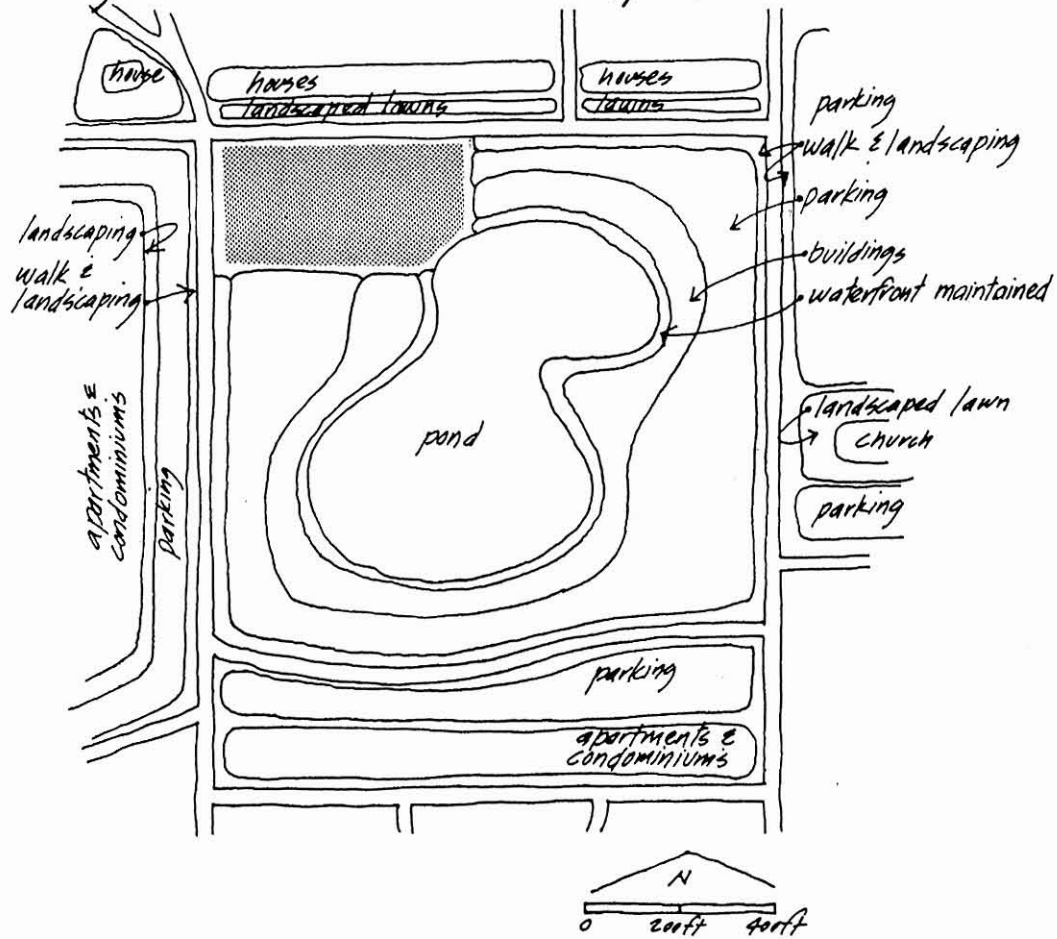

● Pedestrian and vehicular traffic generators

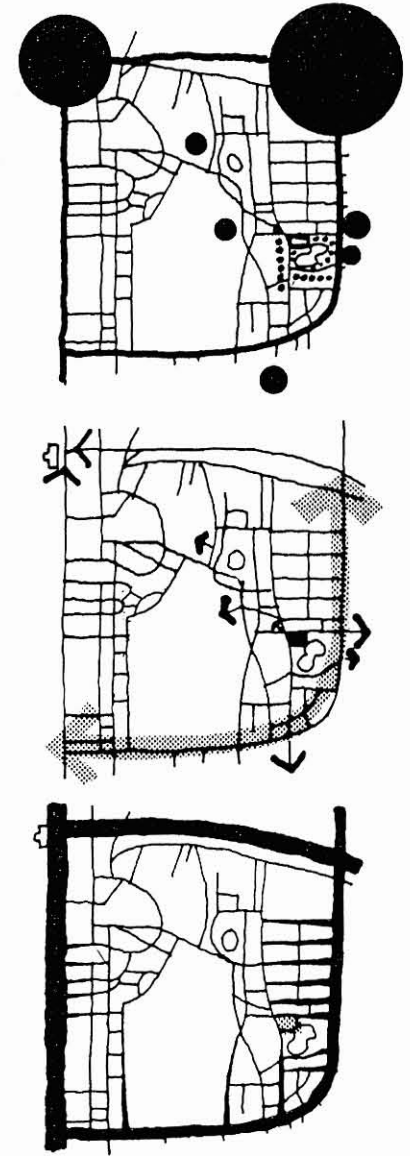
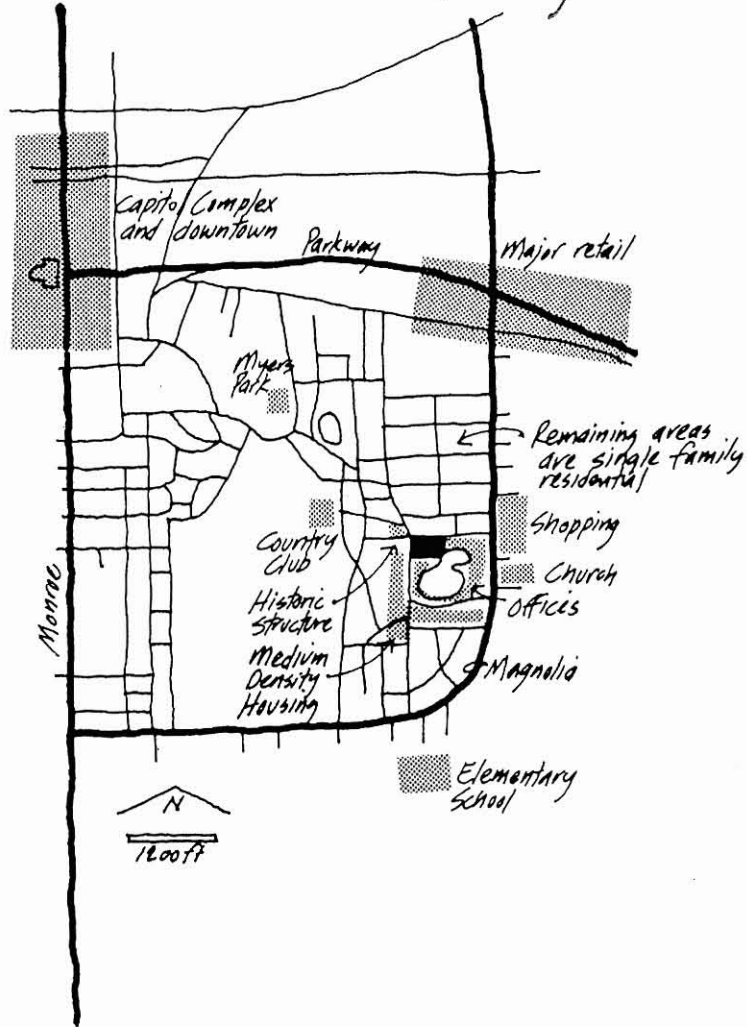

# ● Vehicular circulation patterns

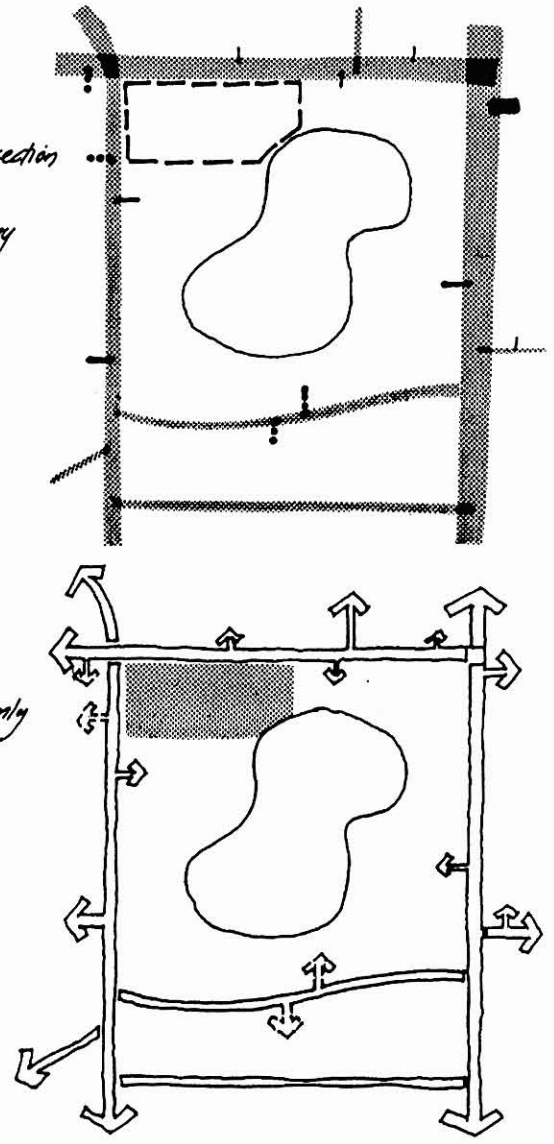
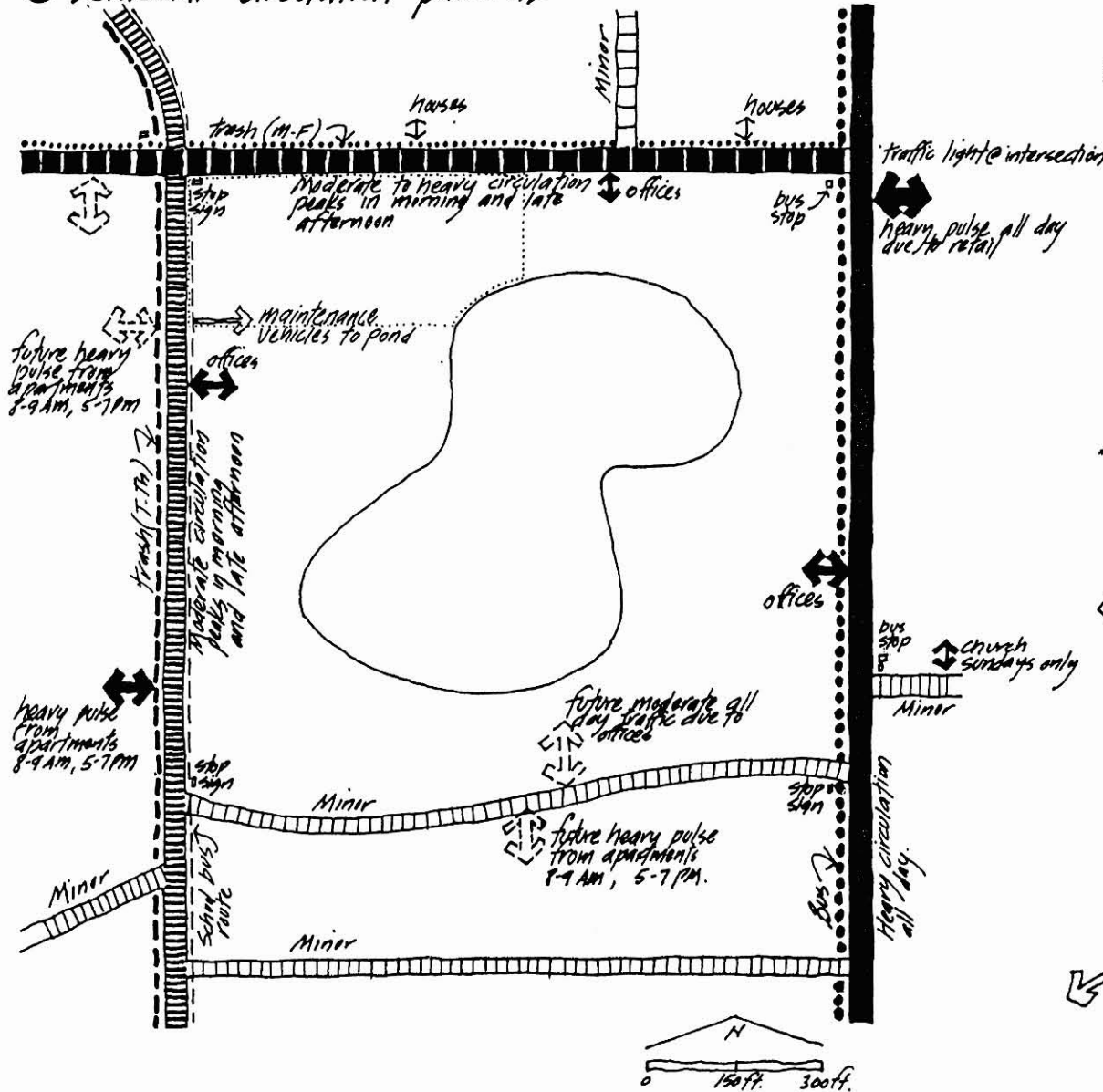

# ● Pedestrian circulation patterns

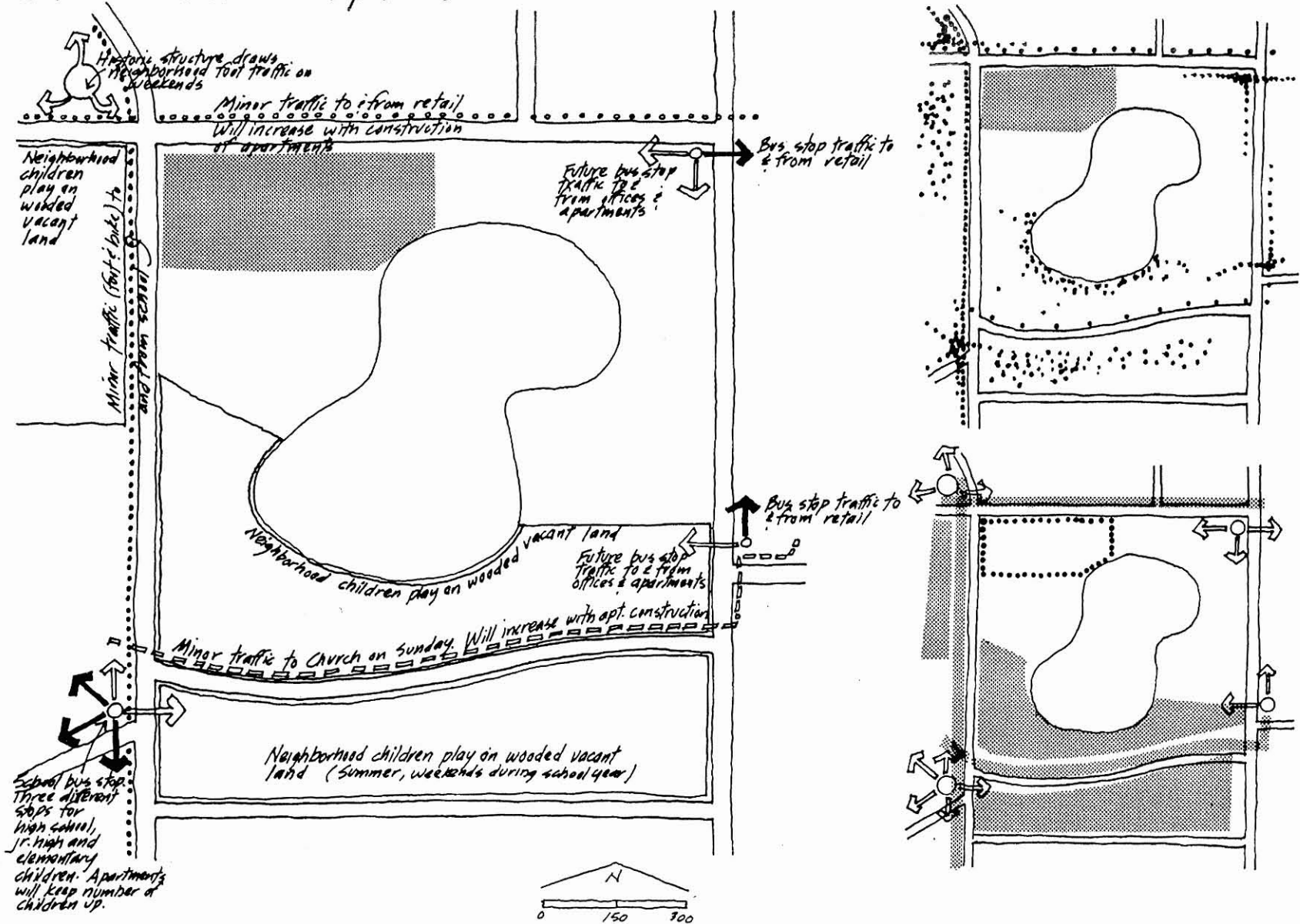

● *Solid-void space relationships*

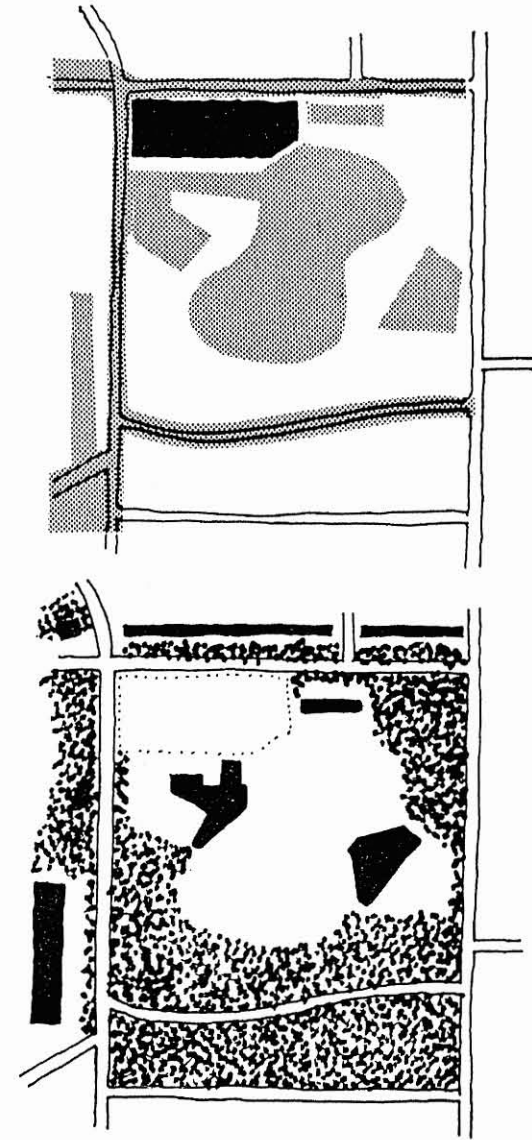
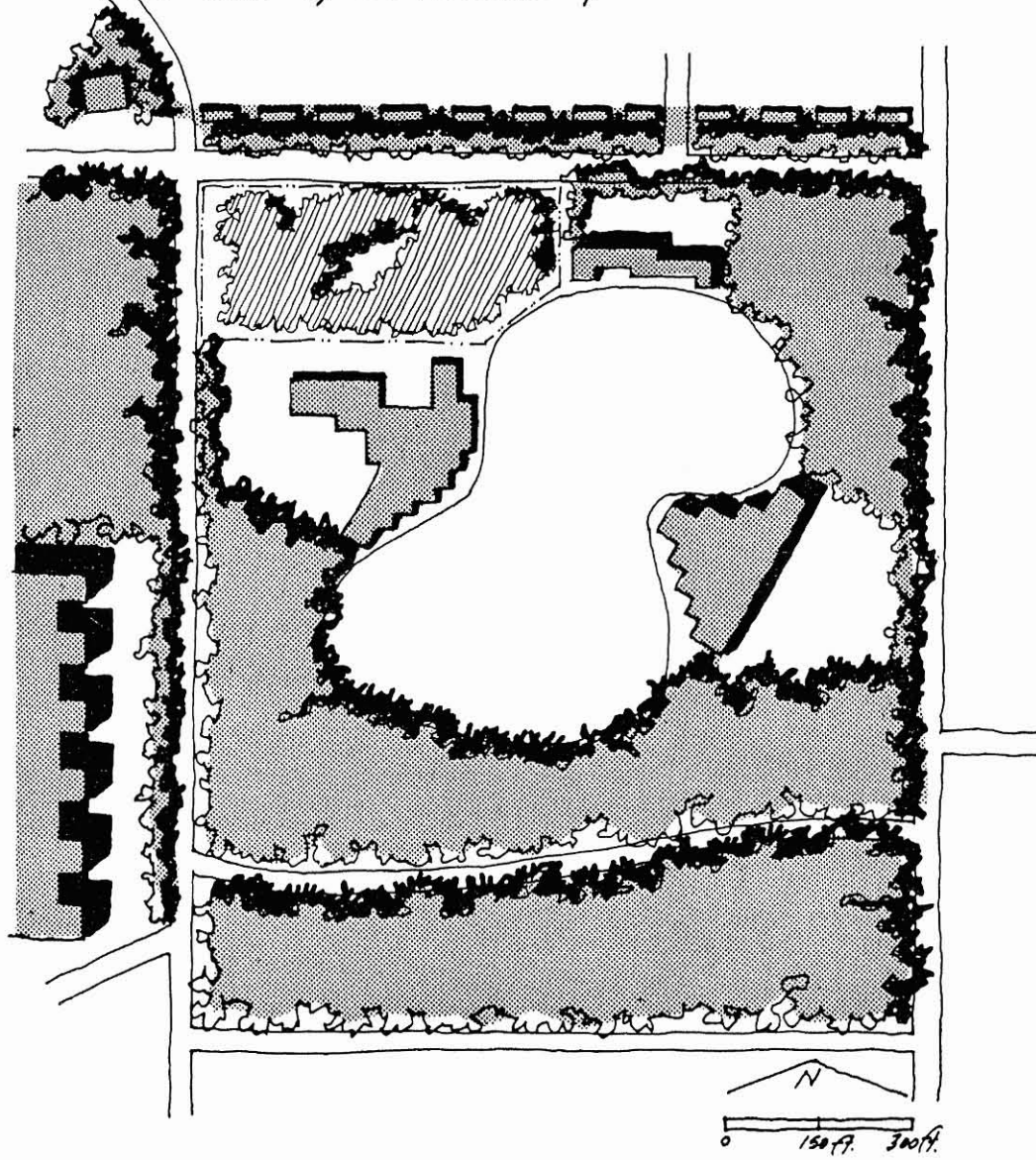

● Exterior lighting patterns

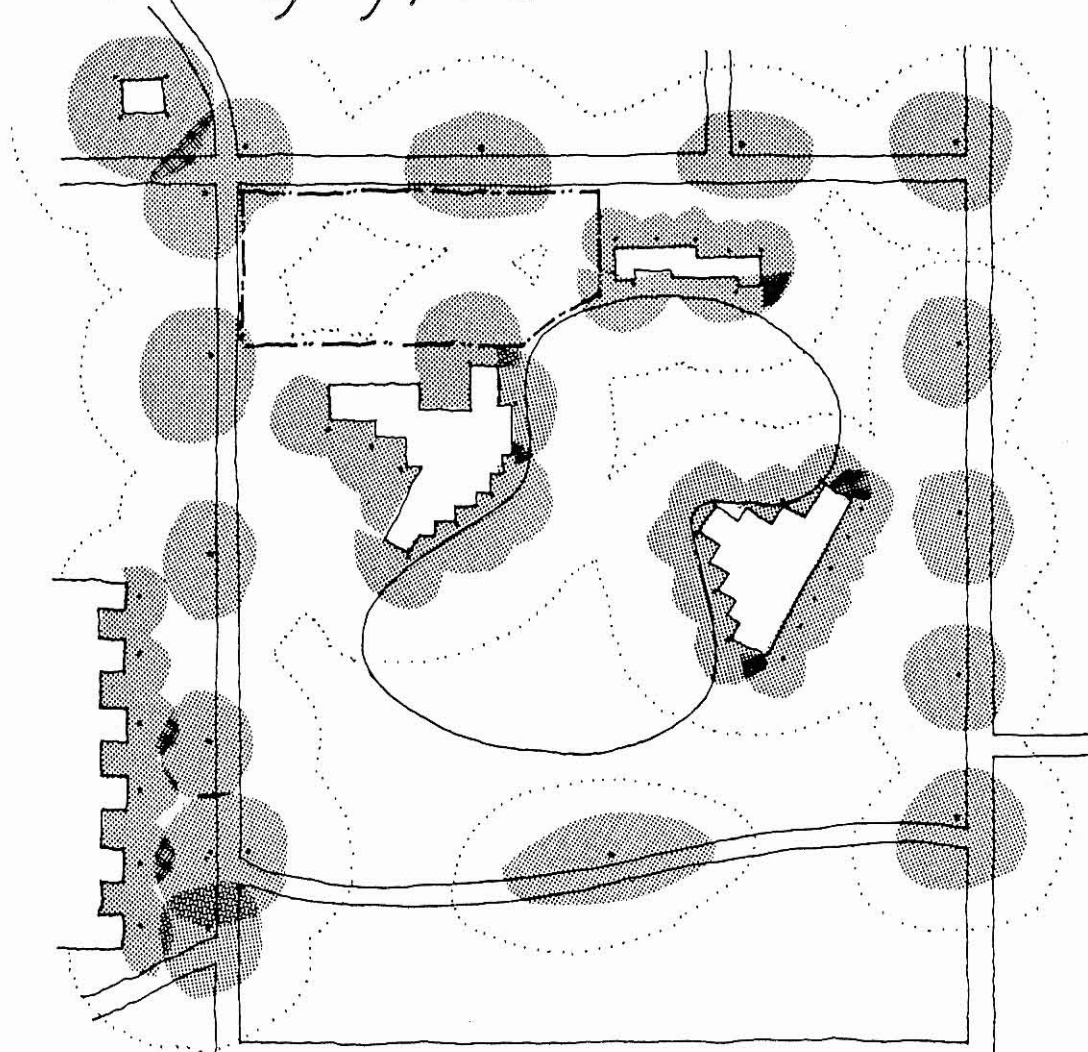

NOTE: toned areas indicate light spread at 5 footcandles. Dotted lines indicate light spread at 1 footcandle.

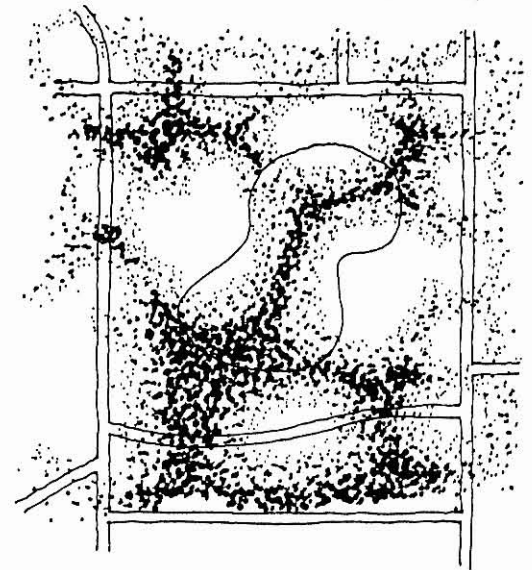
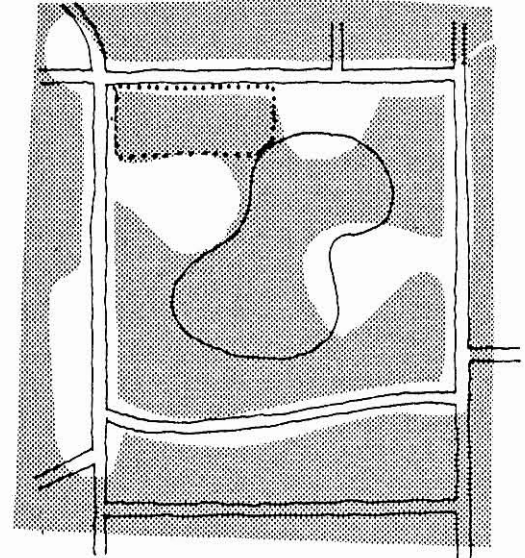
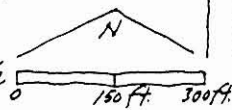



# ● Significant architectural patterns



Historic structure is two story white structure with a brown slate roof. Exterior in horizontal wood siding. Building is on 3' pedestal with open air rail around the 2nd story porch. Open porch on all 4 sides. Columns and pedestal are stone.



Offices around pond are built to strict image requirements: vigorous roof profile, lumpy form, wood exterior, shake shingle roof, pitched shed roof, porch perimeter and natural landscape on pond side.



Typical subdivision architecture all along Maple Drive. Hip roofs with dark asphalt shingles. Mixture of brick and wood siding on exterior. Garage doors facing street.



Blocky, 5 story apartments with brick exterior. Emergency stairs at ends of wings present concrete faces to Seminole Drive. 50' deep landscaped entry courts between protruding wings. IBM card window pattern. Landscaping in entry courts and in right of way at street softens image considerably.

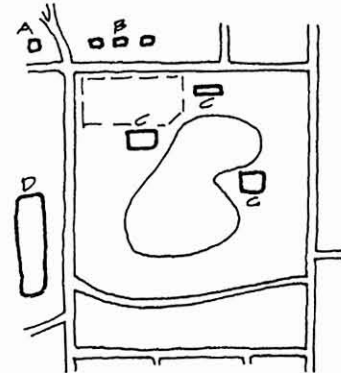
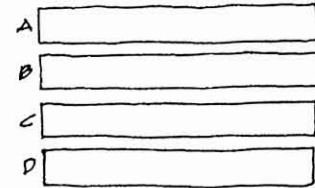
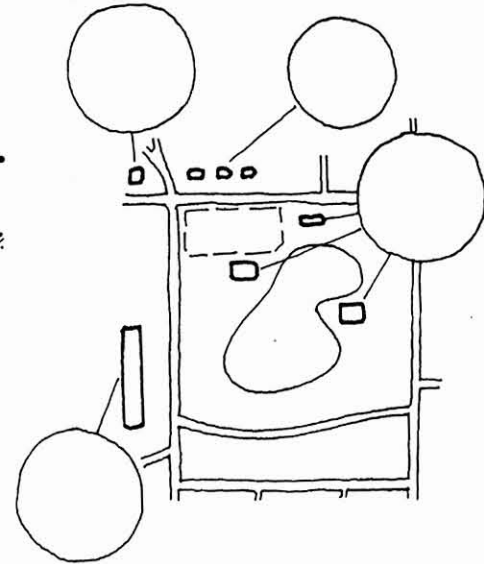
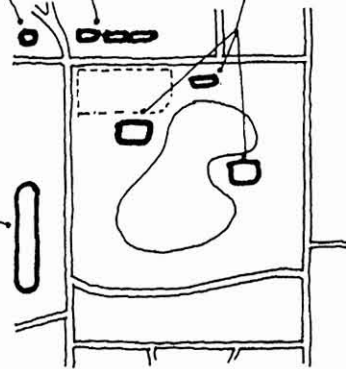

● Significant classifications

Corner site zoned "H" (Historic Site). Restored plantation home now serving as a museum. No special restrictions on surrounding development.

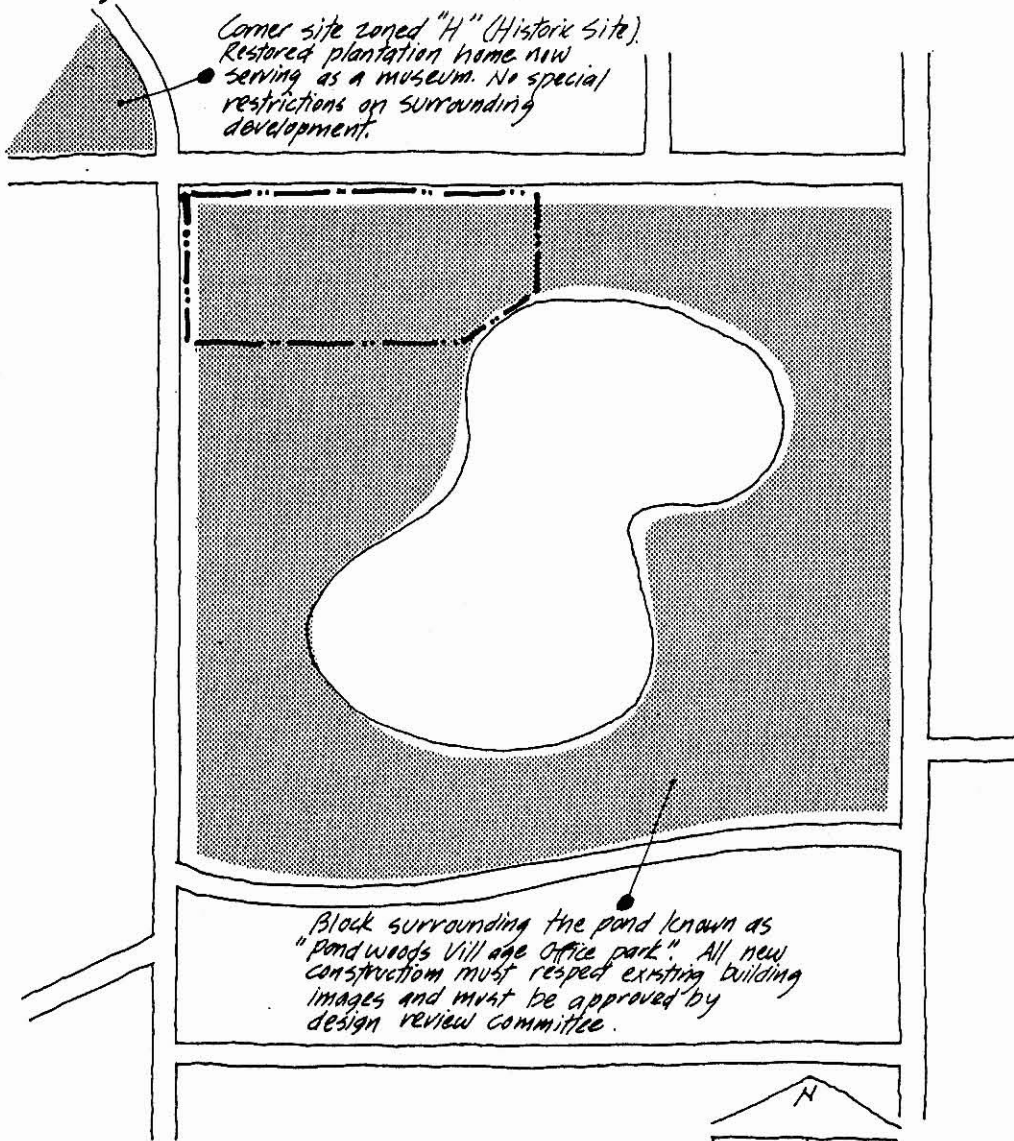

Block surrounding the pond known as "Pond Woods Village Office Park". All new construction must respect existing building images and must be approved by design review committee.

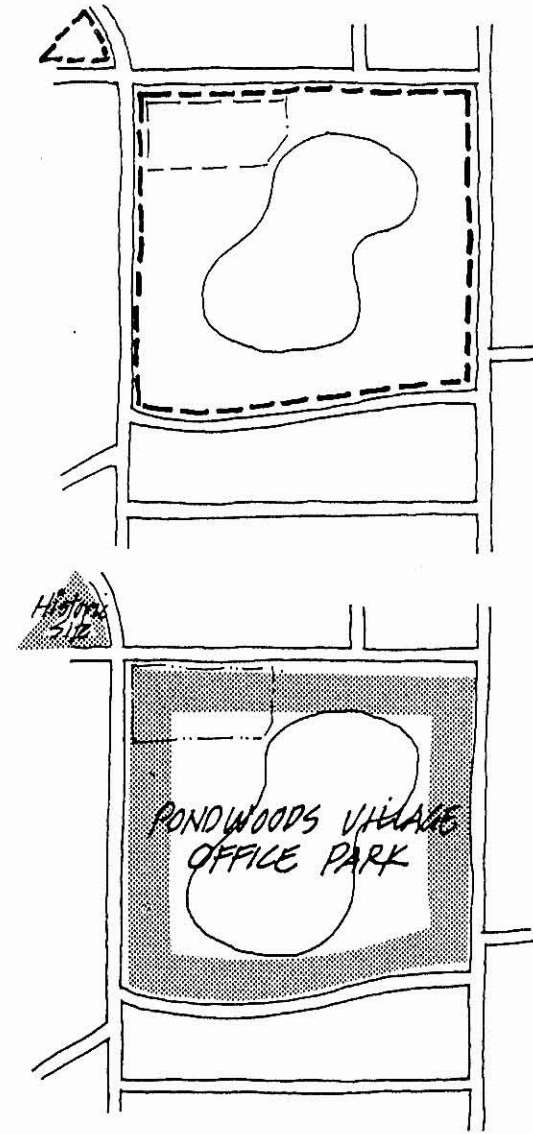

● Nearby buildings of particular value or significance

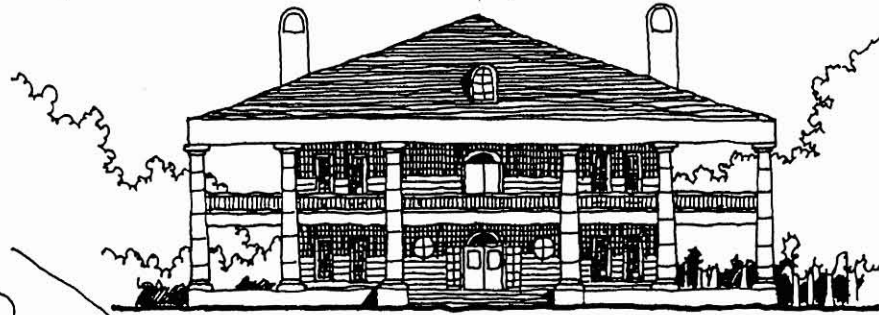

100 year old restored plantation home. Funds provided by City of Tallahassee and Federal Government. Building operated as a museum of Tallahassee History by City Preservation Group. Museum open year round including weekends. Operating hours 10-5 on weekdays and 10-4 on weekends. Festivals drawing 10,000-15,000 people per day held twice a year (Christmas and mid-summer.)

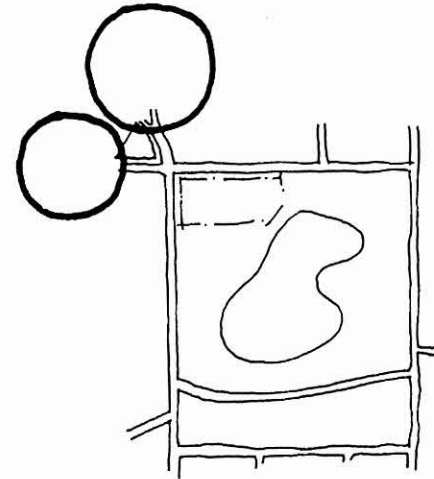
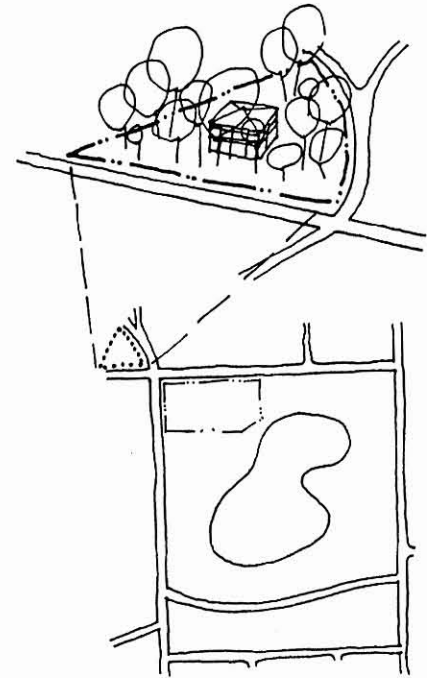
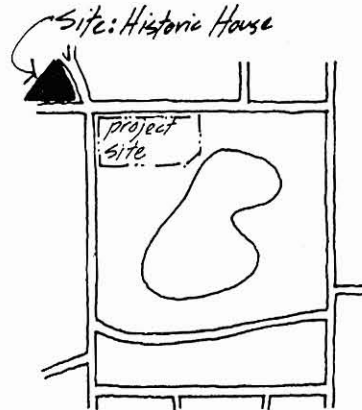
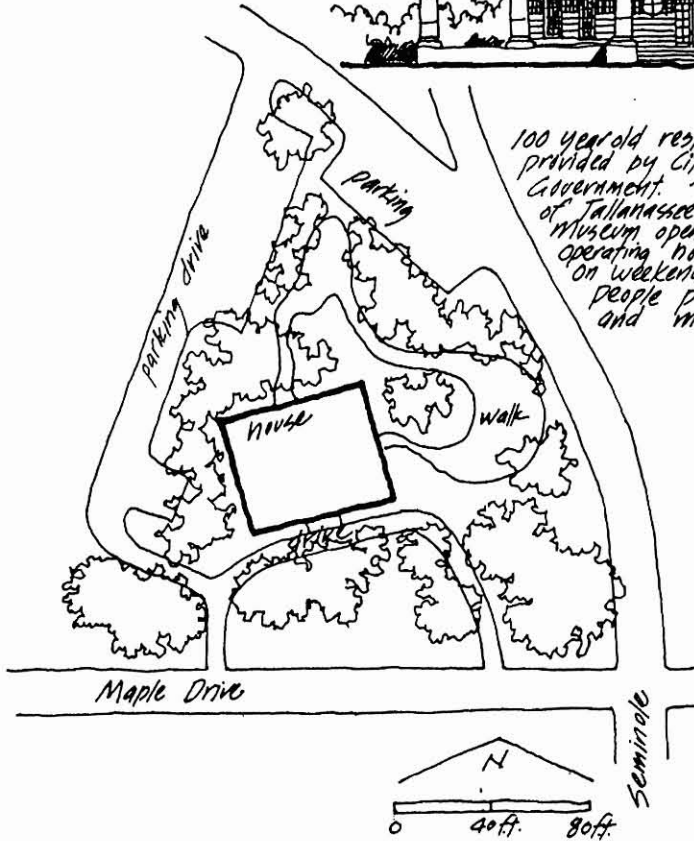

● Sun-shadow patterns

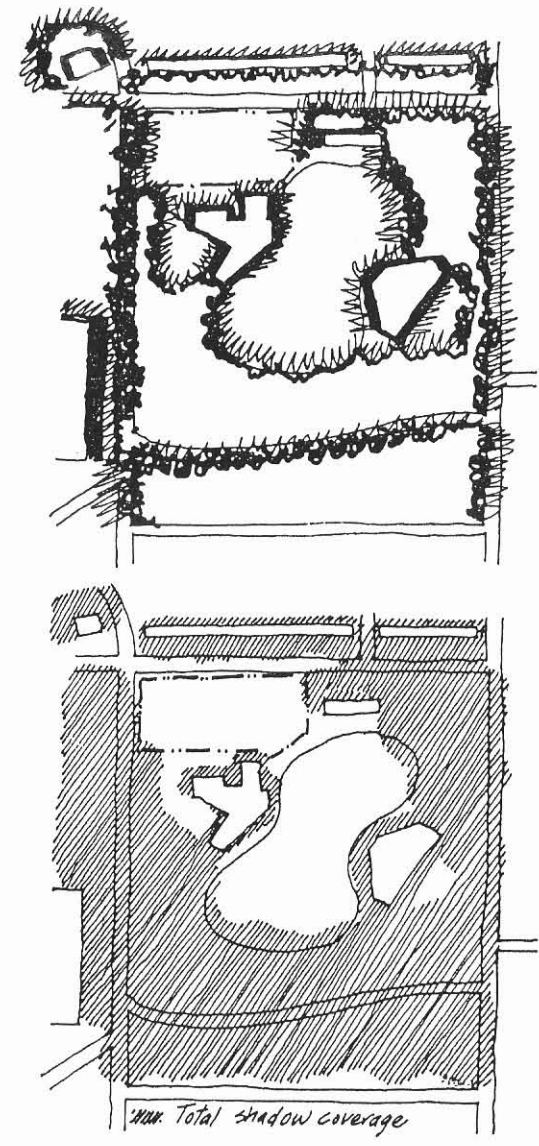
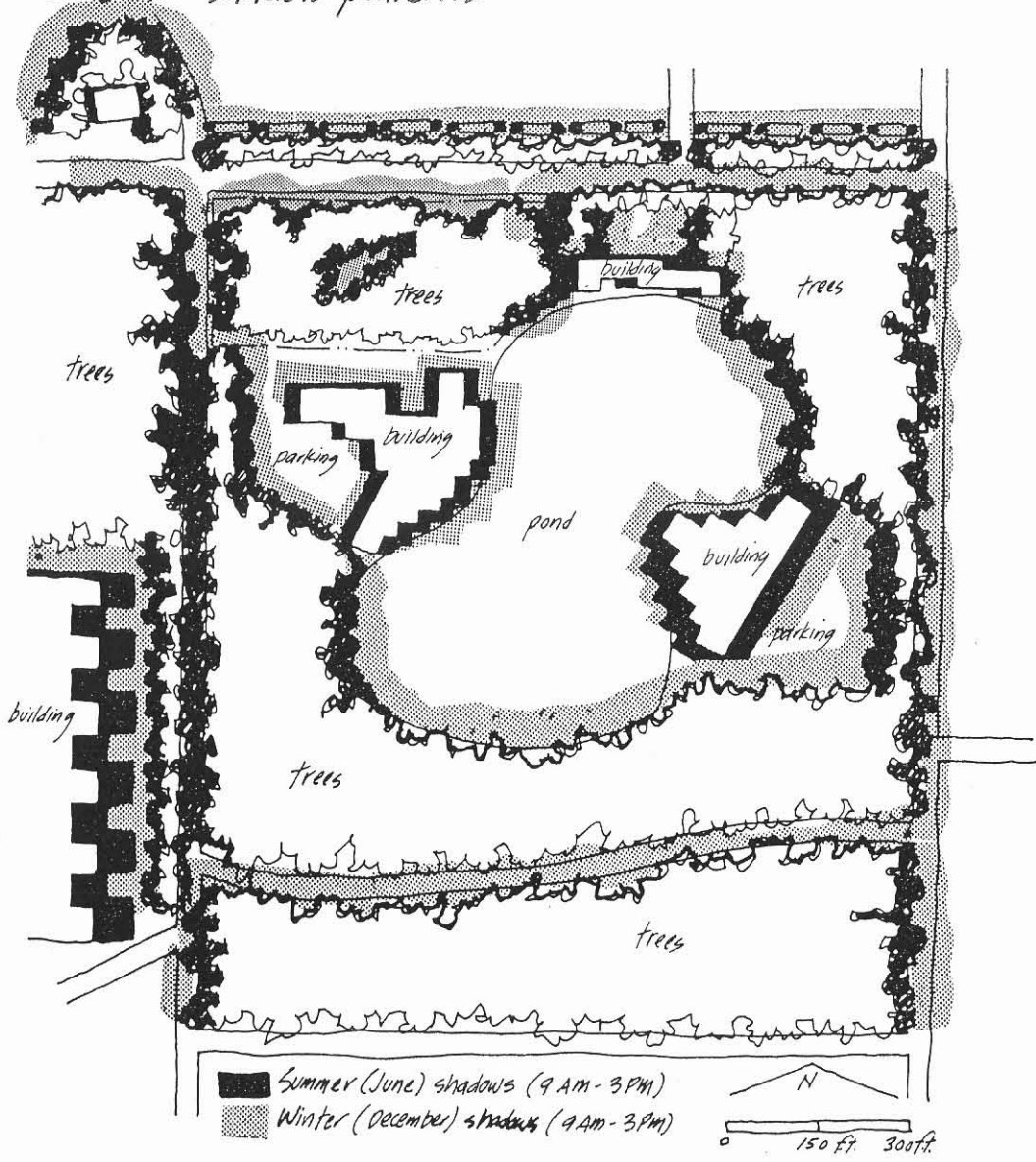

● Contours

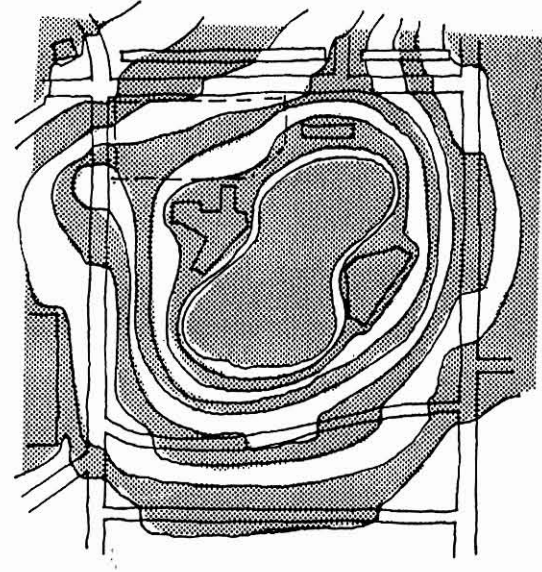
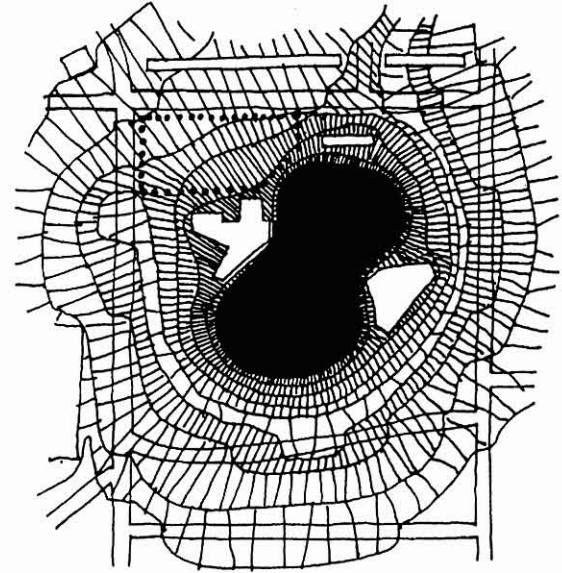
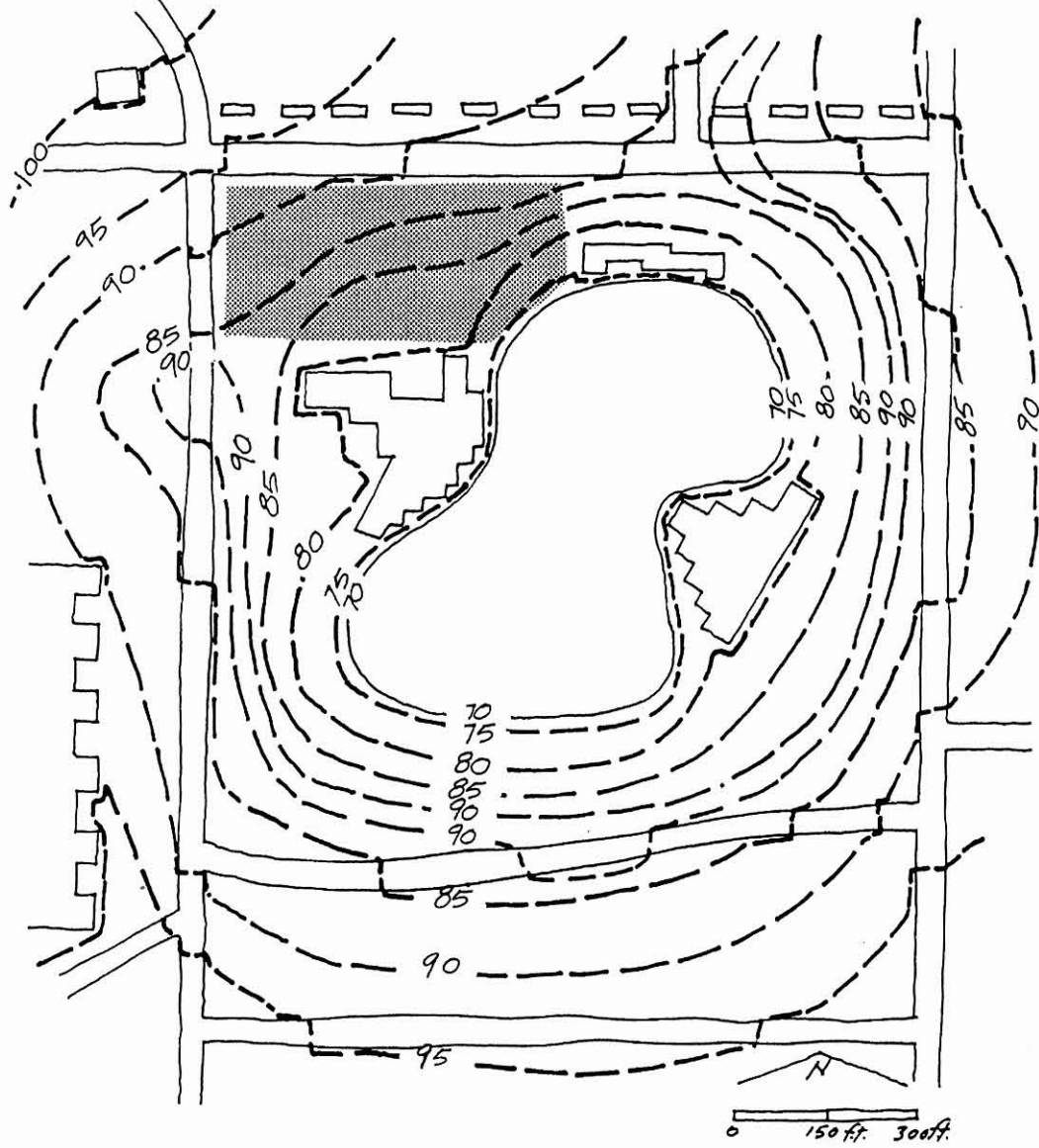

# ● Major land features

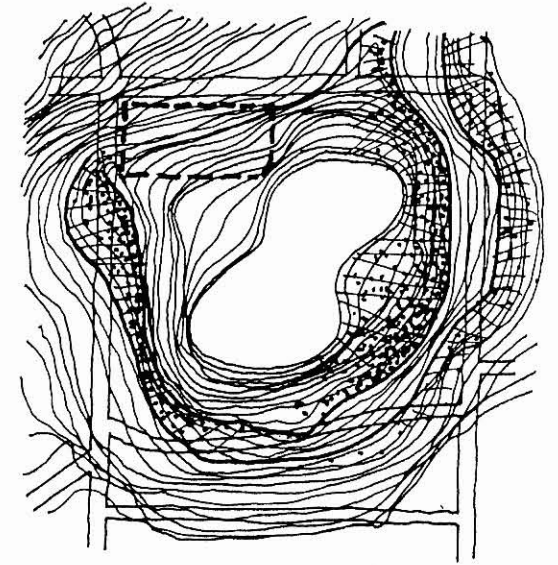
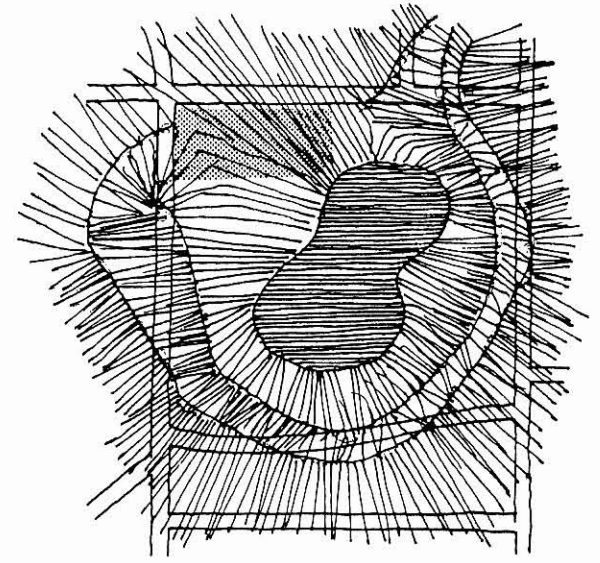
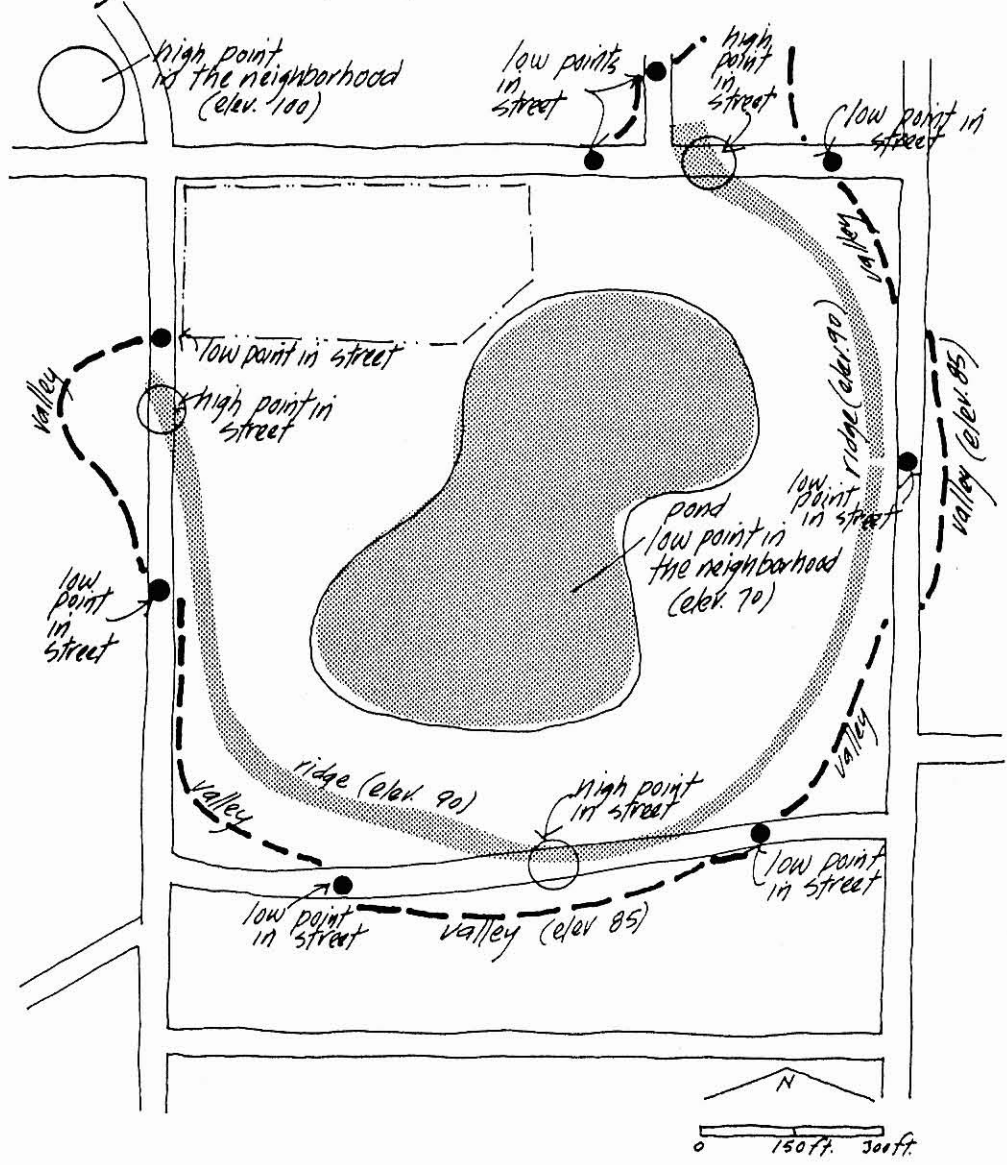

● Surface drainage patterns

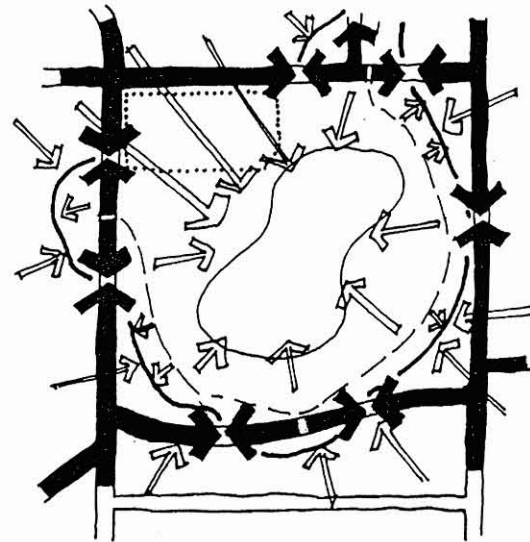
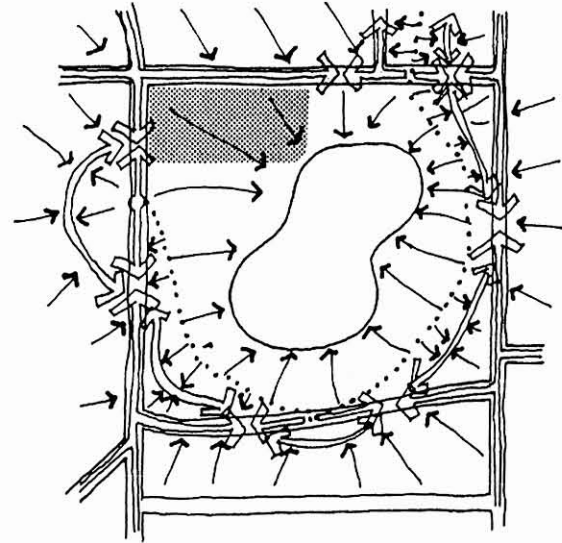
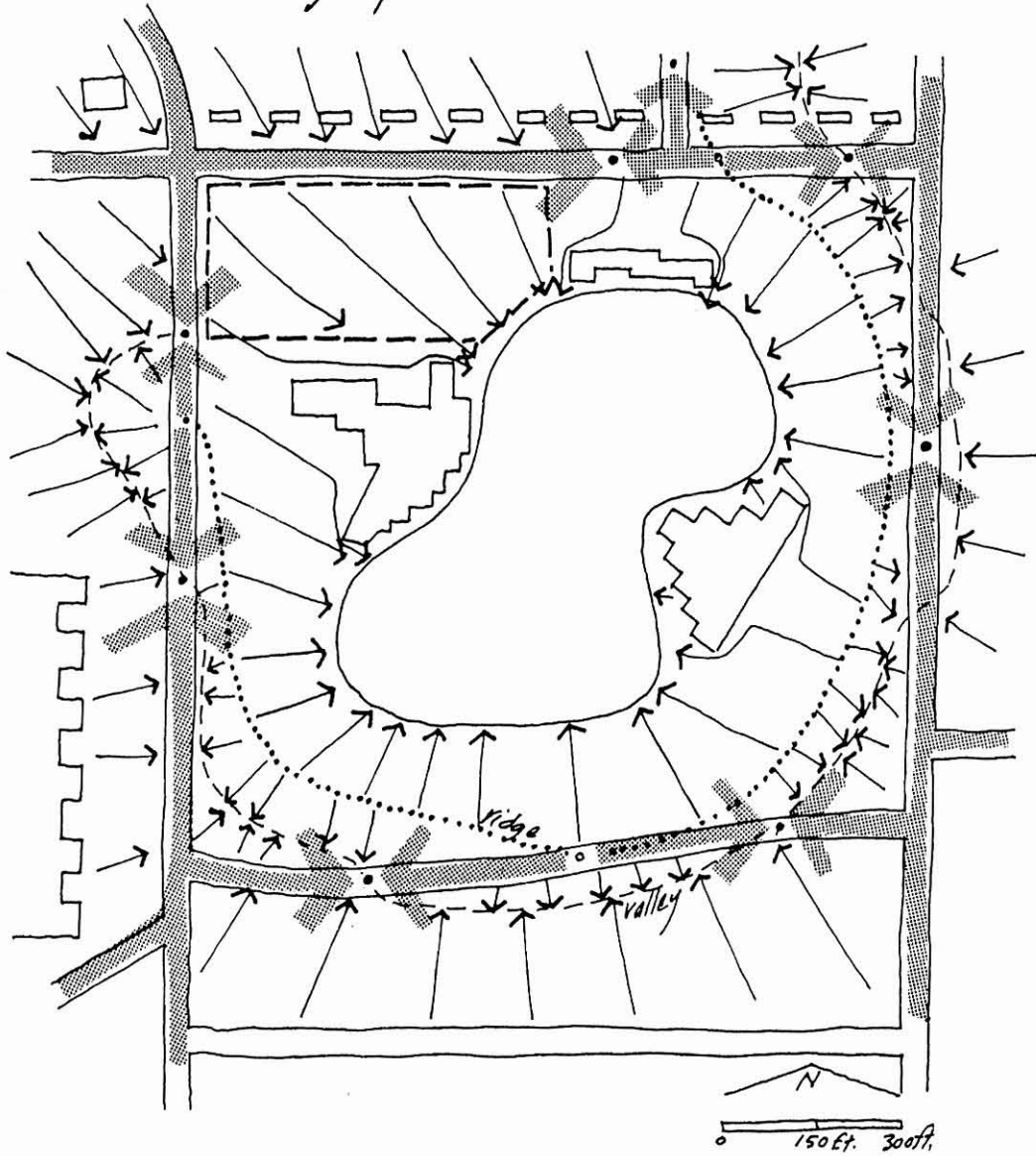

● *Underground storm sewer system*

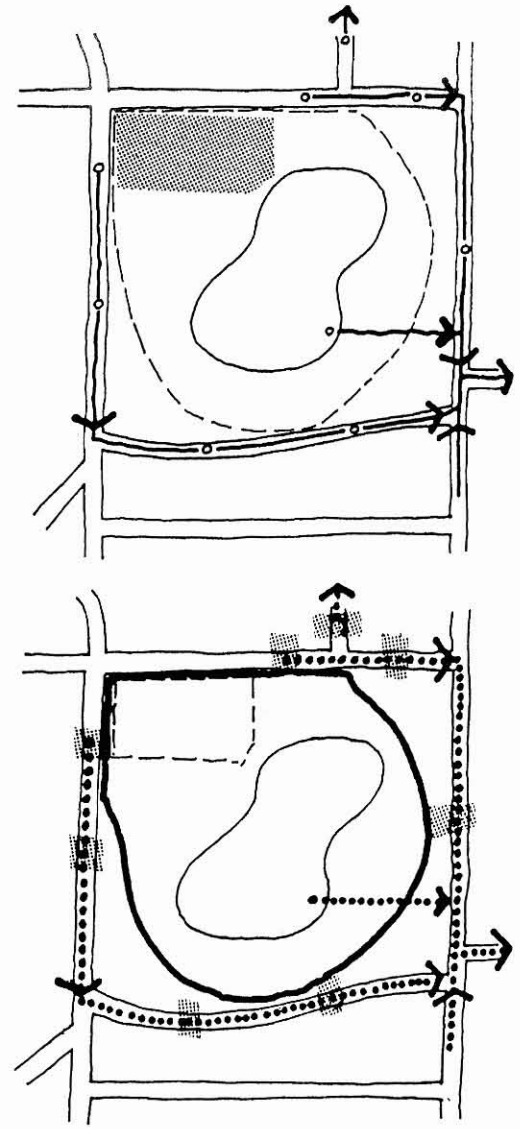
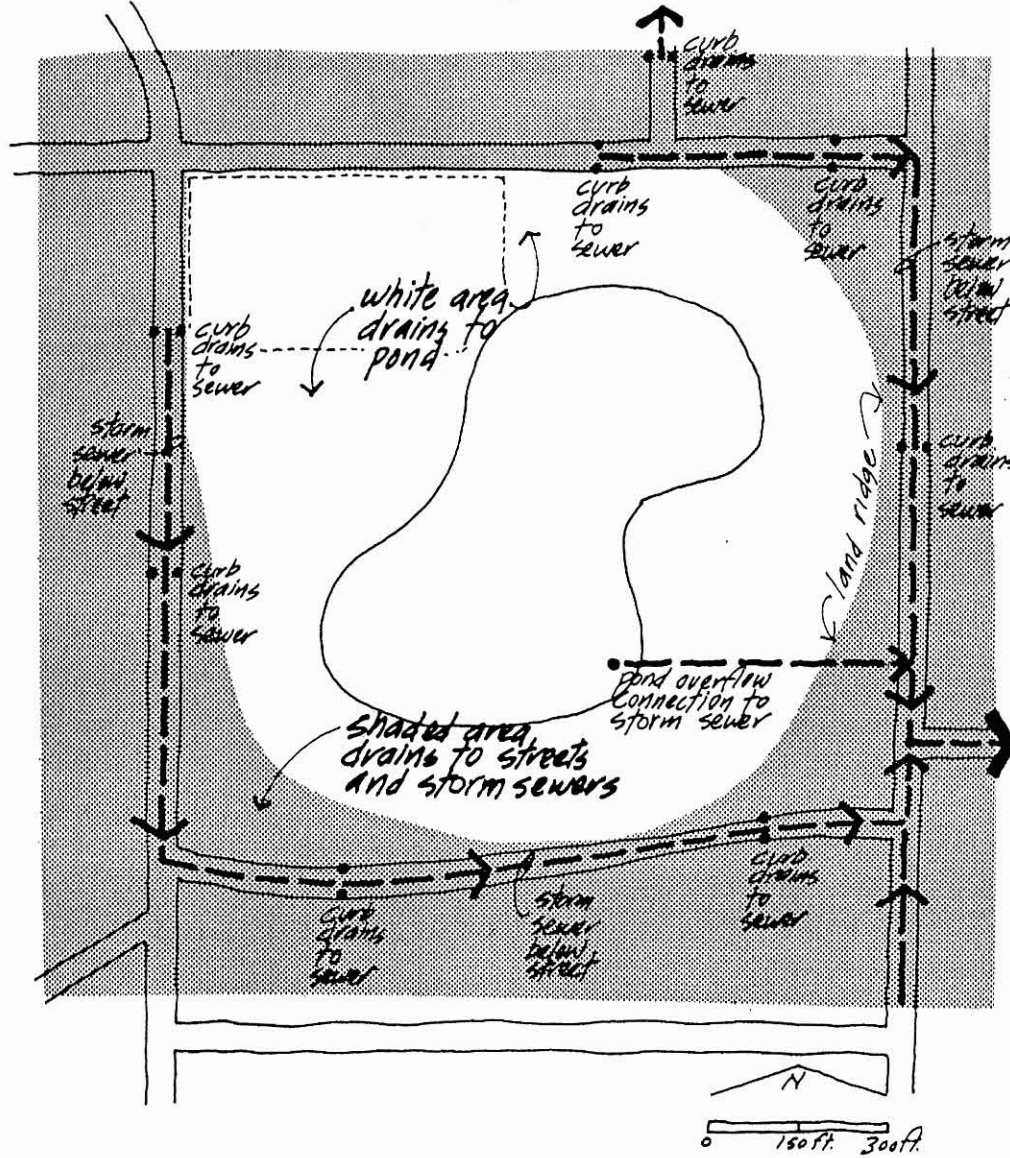



# ● Vegetation

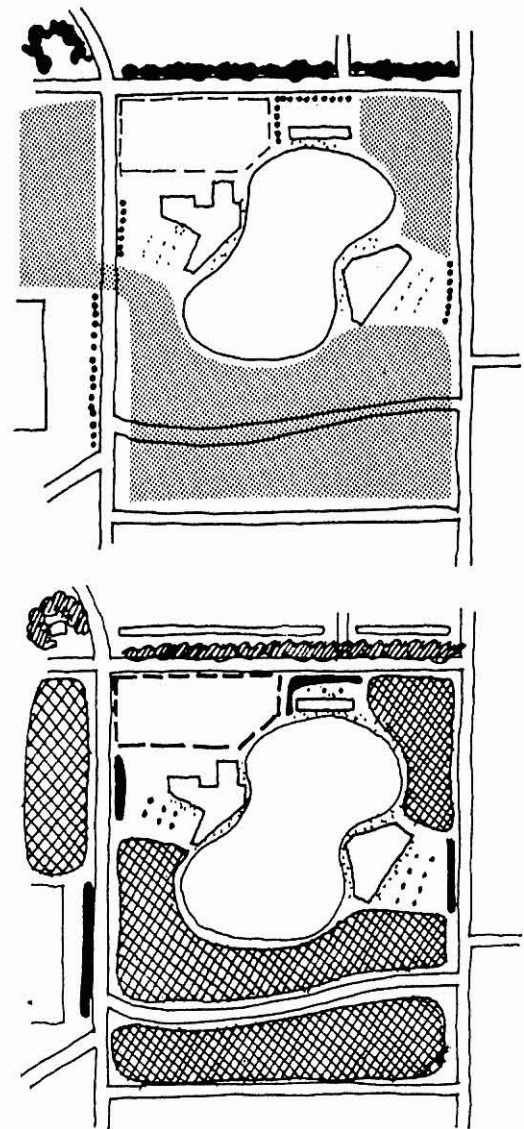
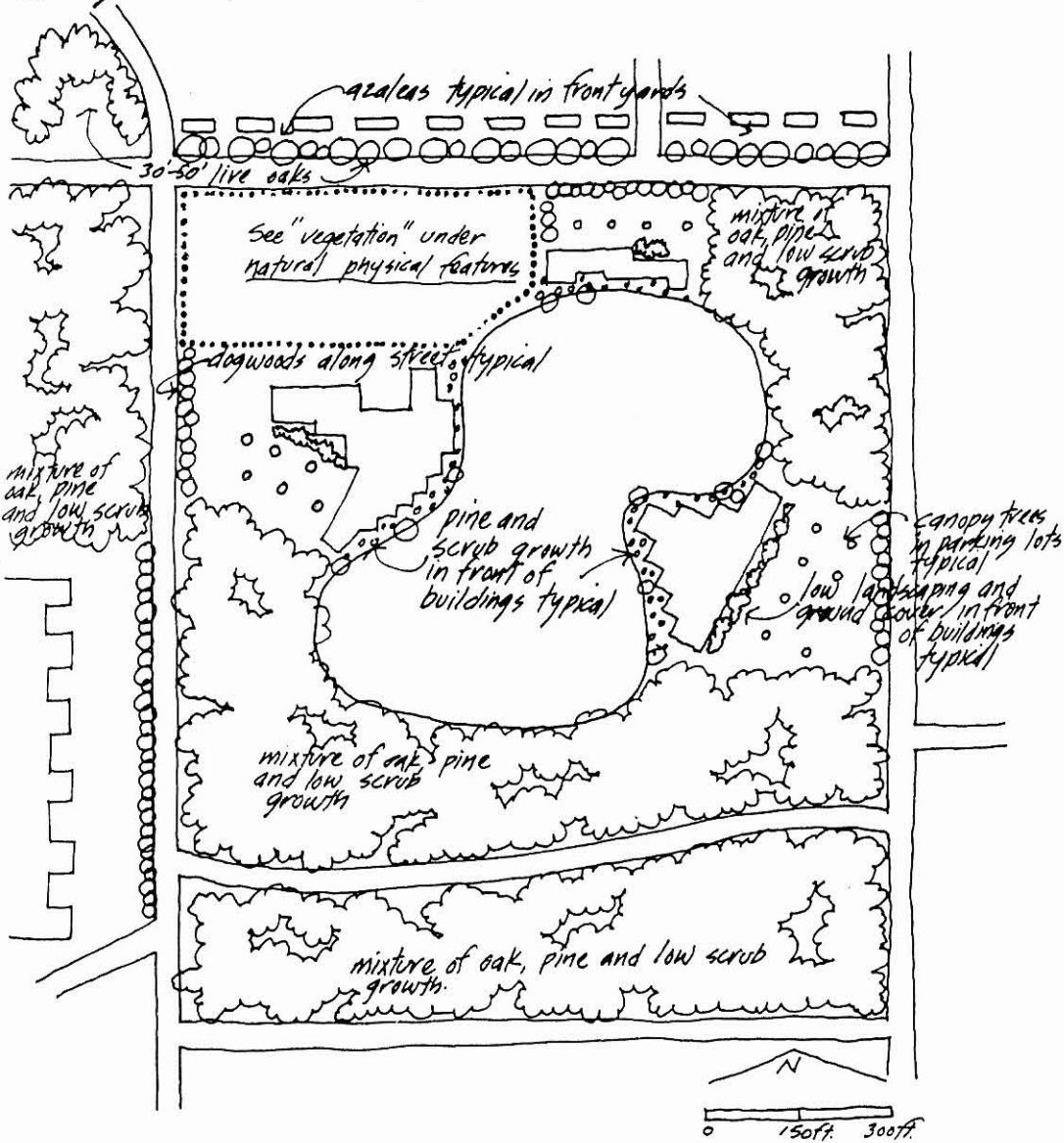

# Size and Zoning

## ● Boundaries and site area

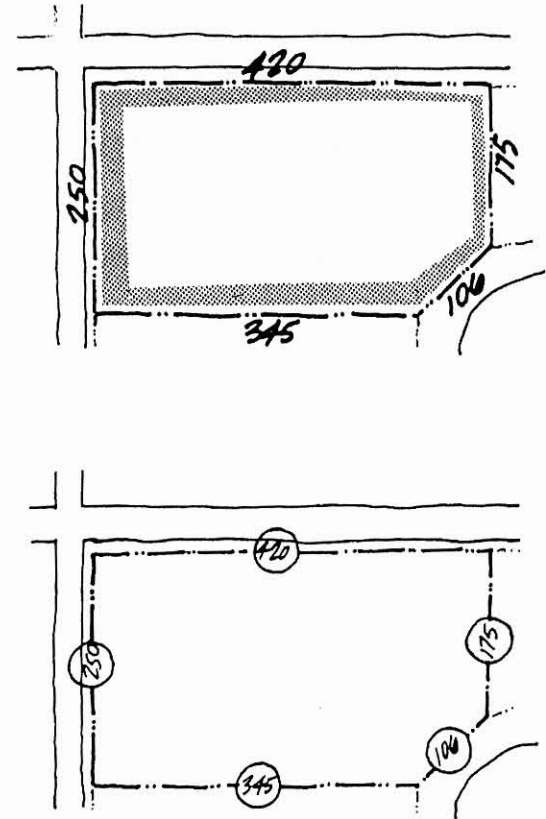
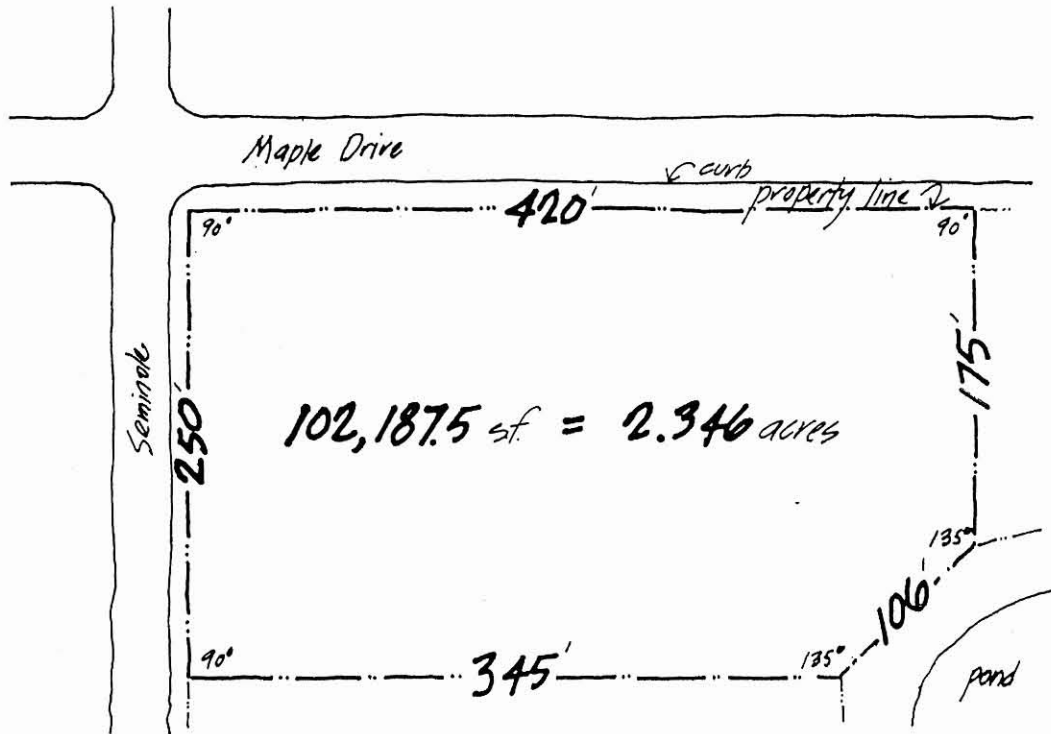

● Street rights of way

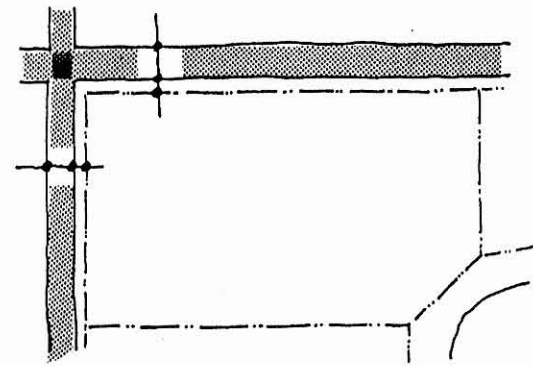
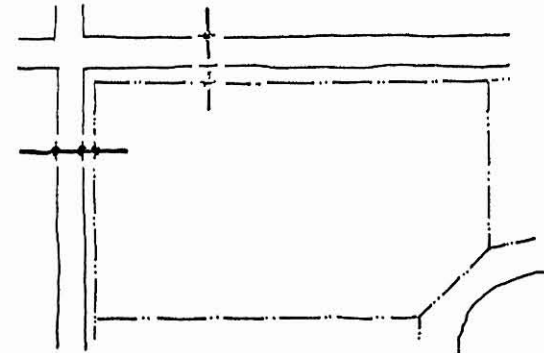
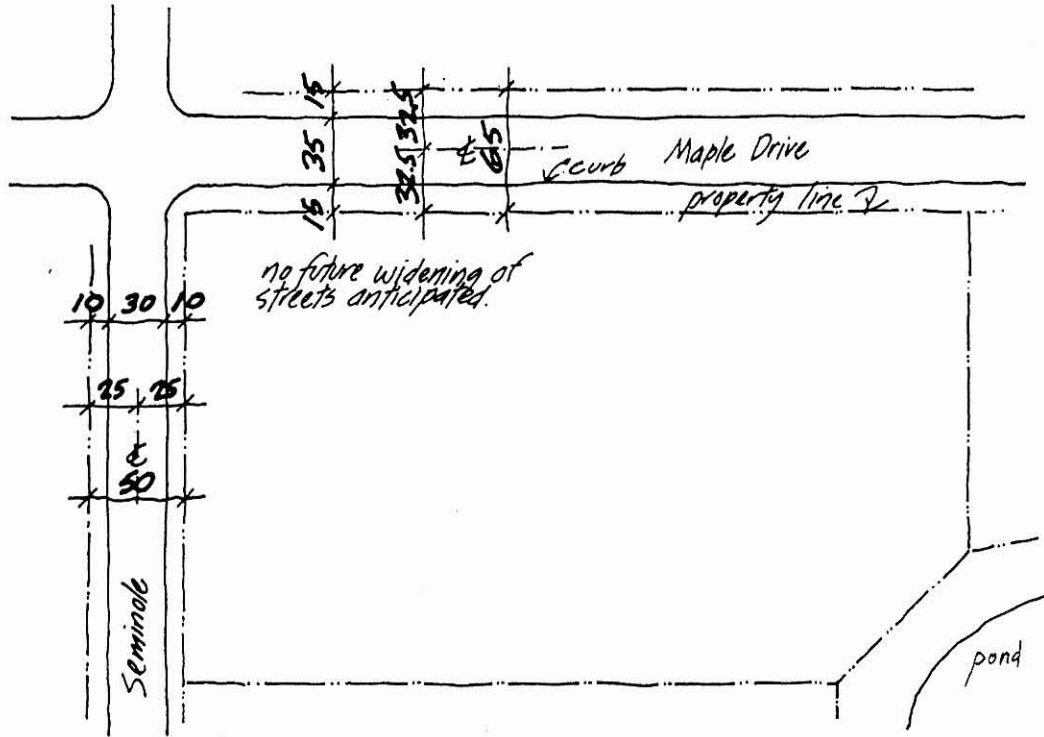

# ● Easements

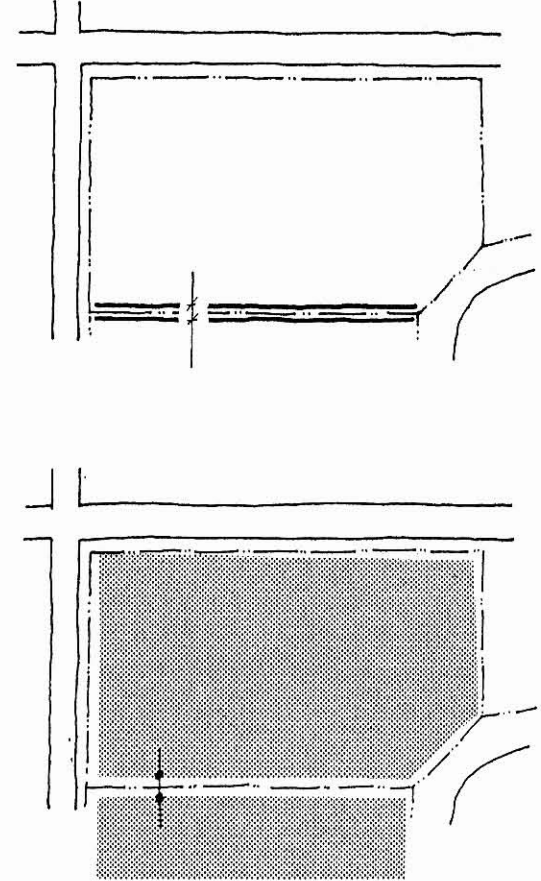
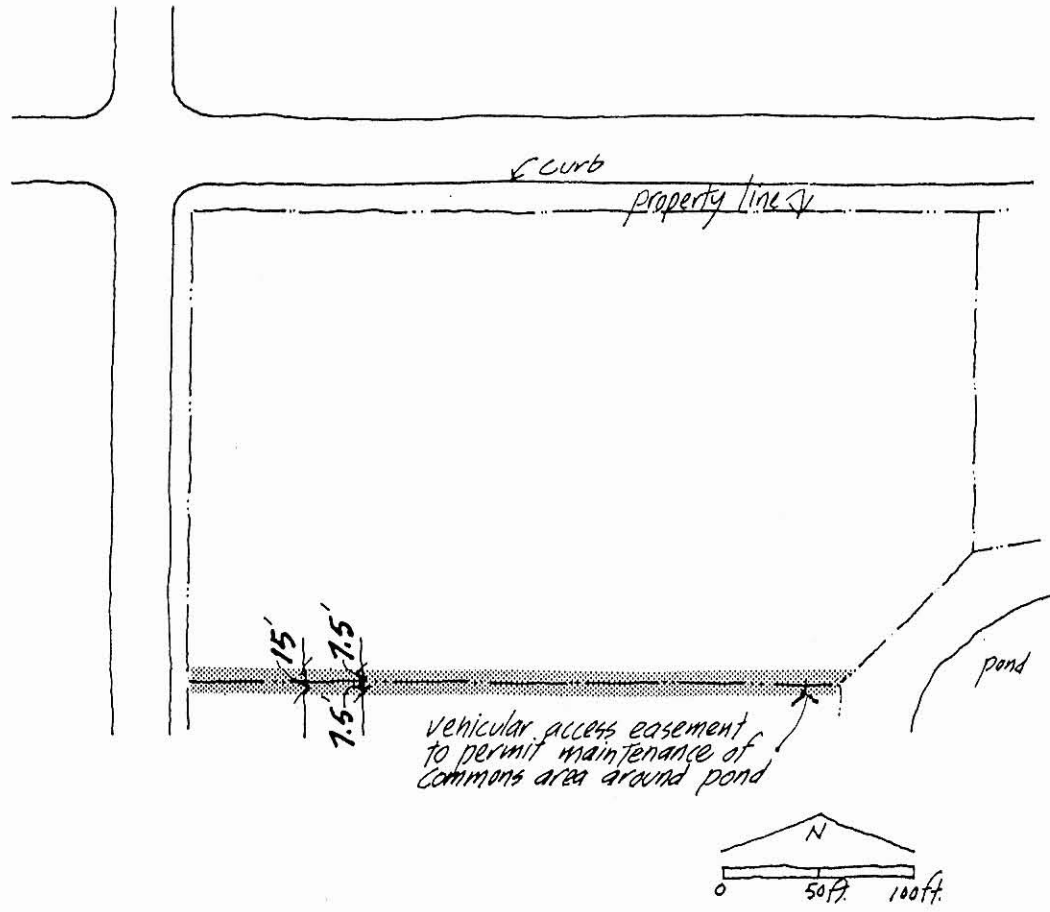

● Zoning and setbacks

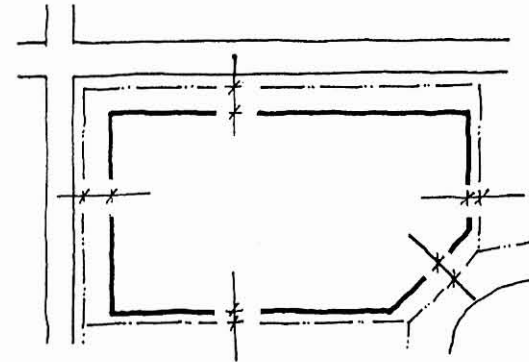
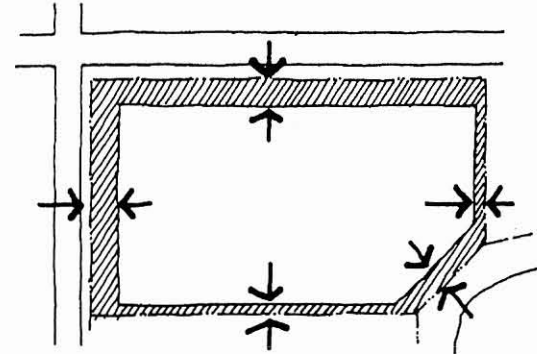
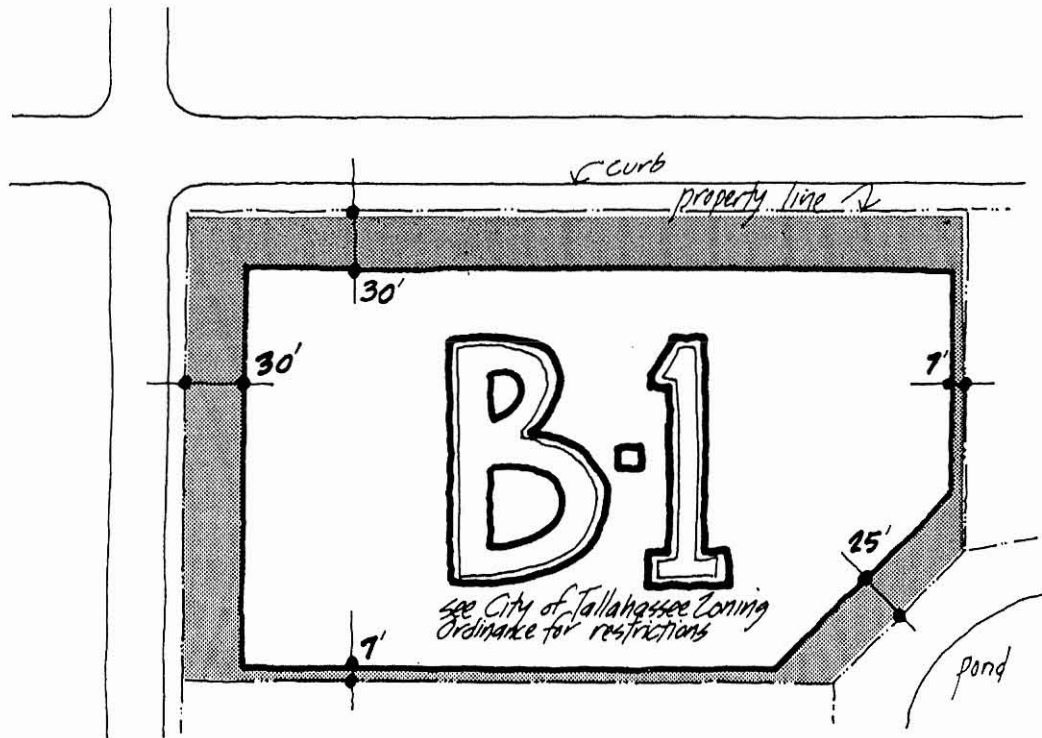

● Buildable area

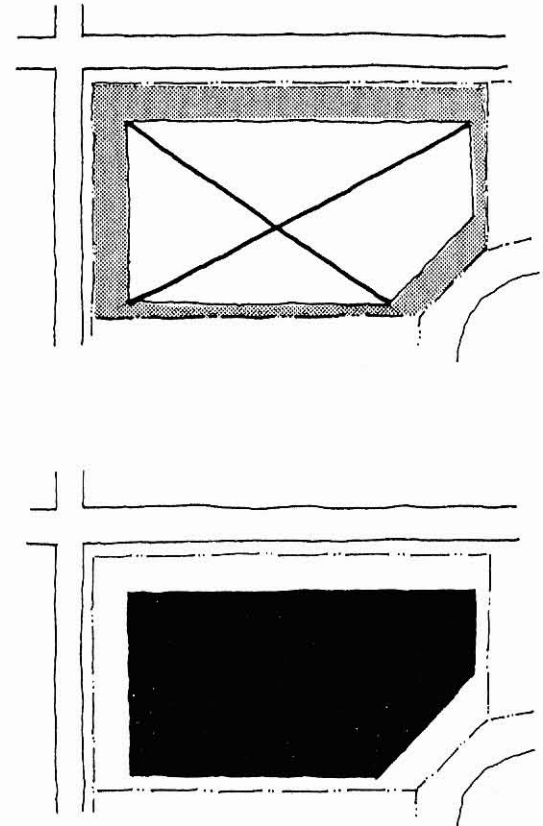
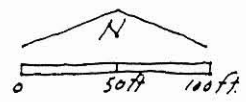
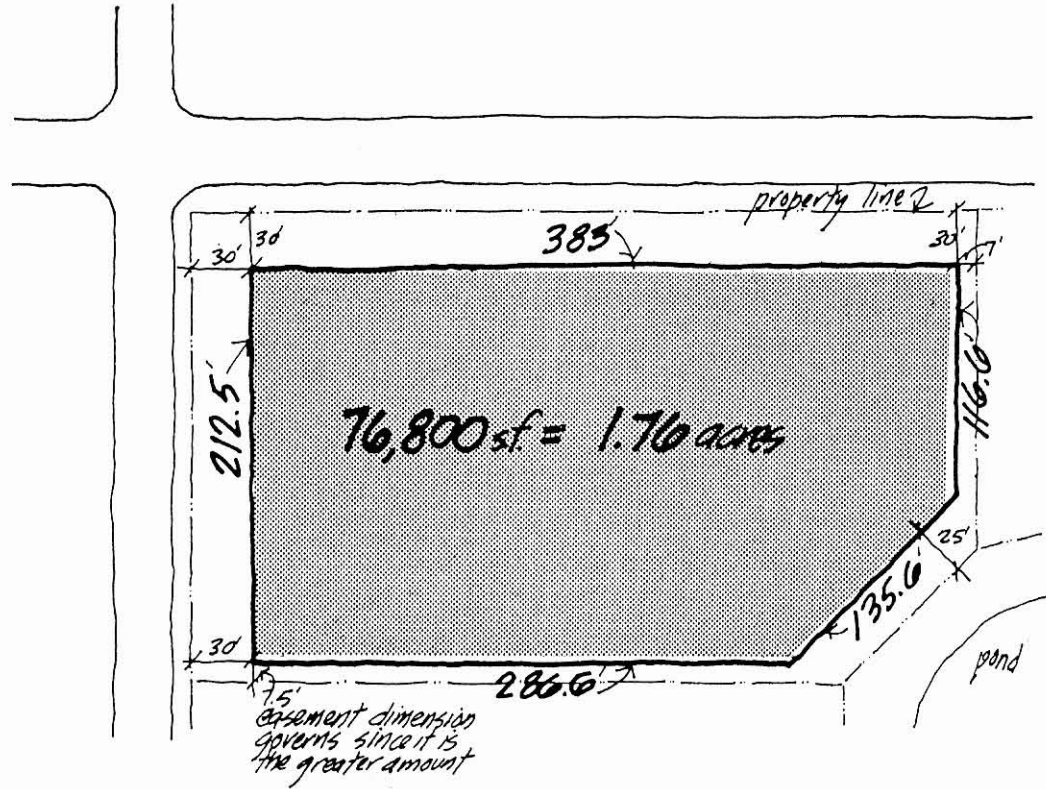

● Site coverage and building height limit

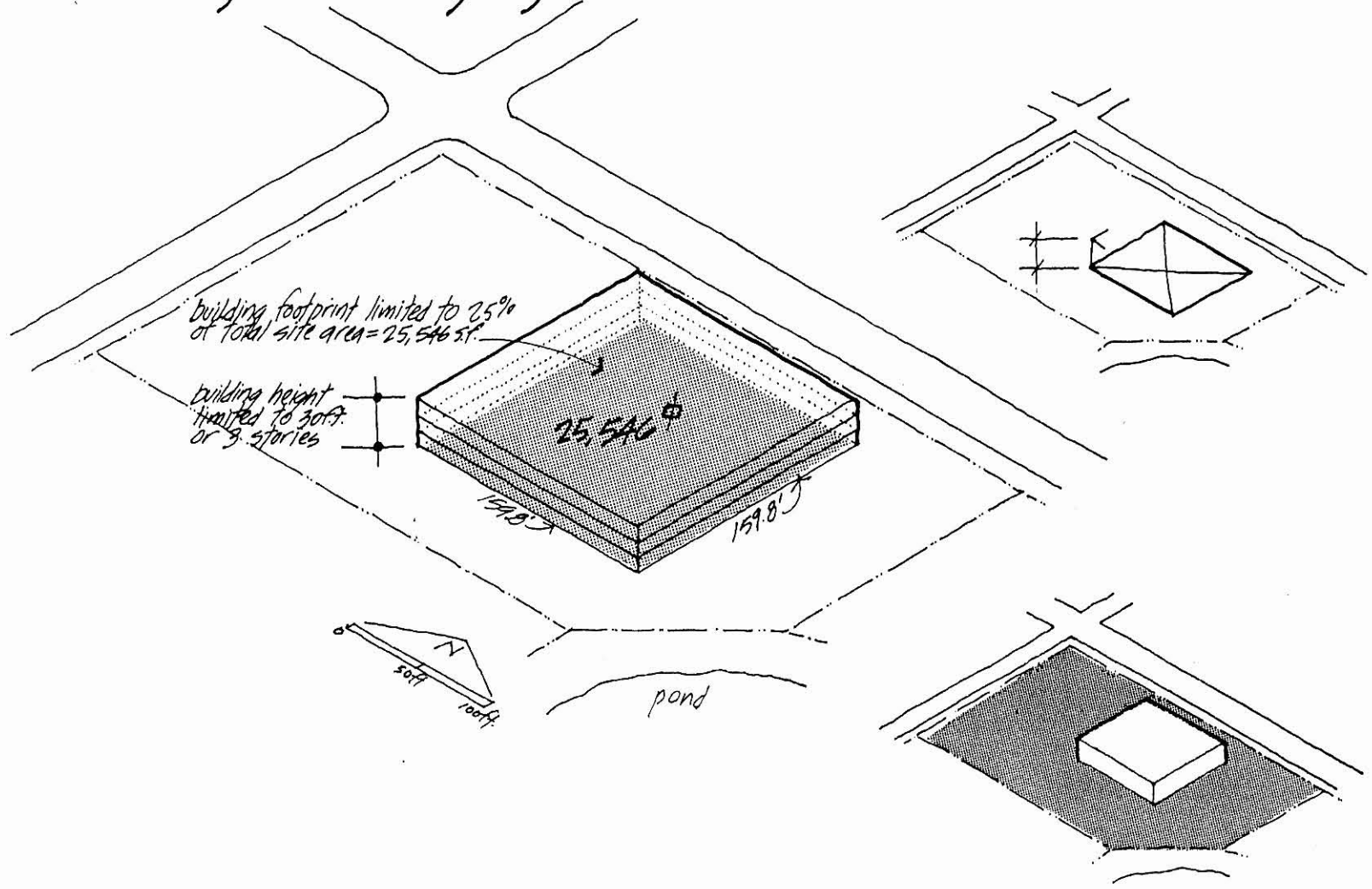

- Off street parking required

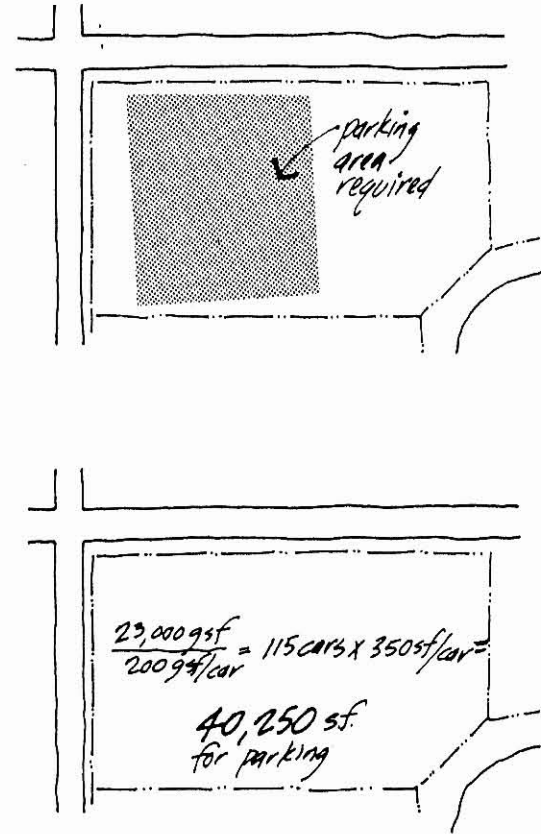
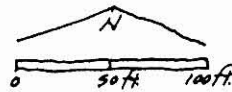
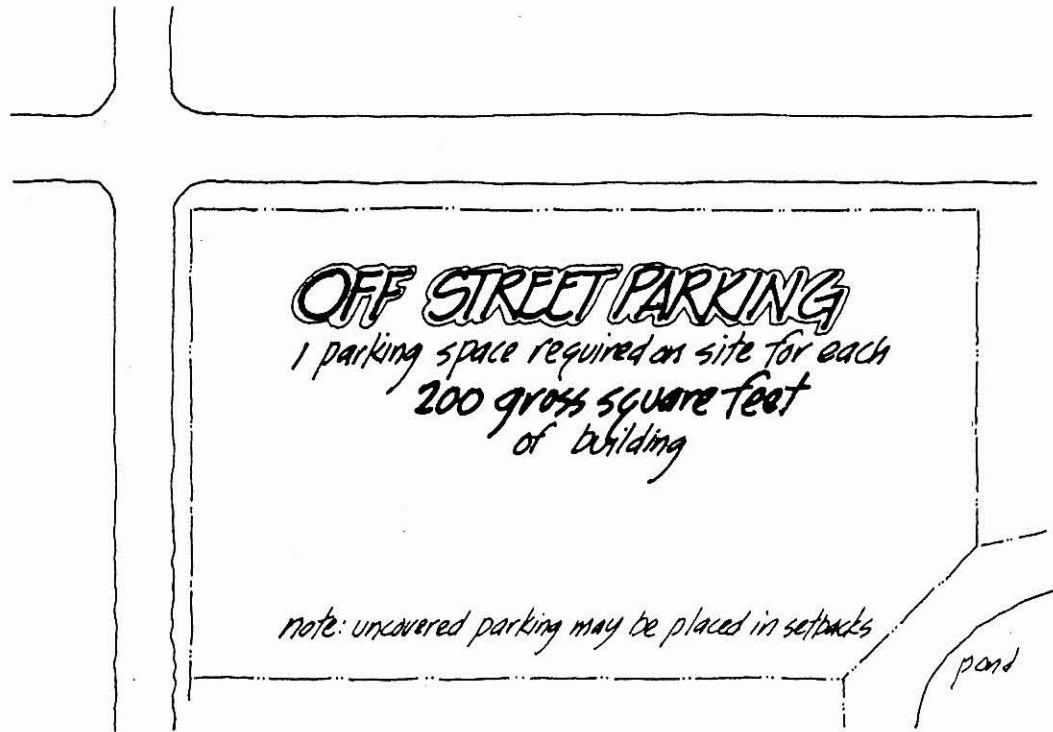



# Legal

## ● Legal and covenants

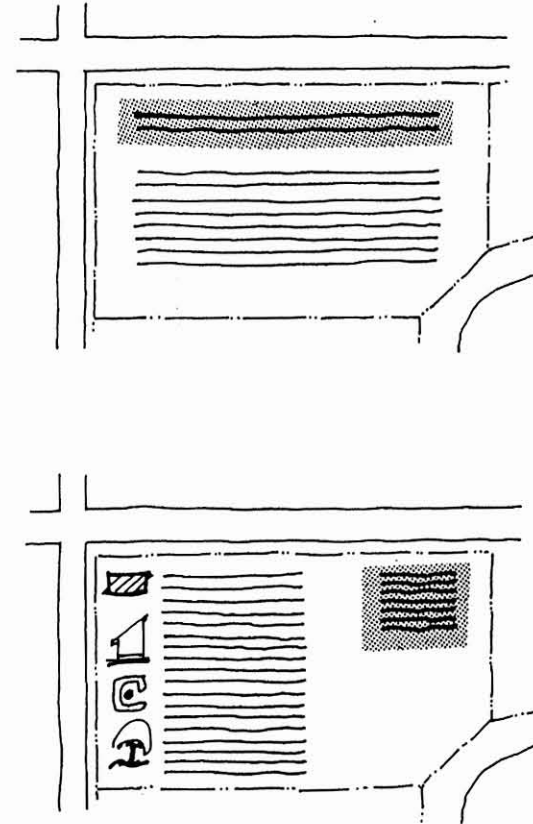
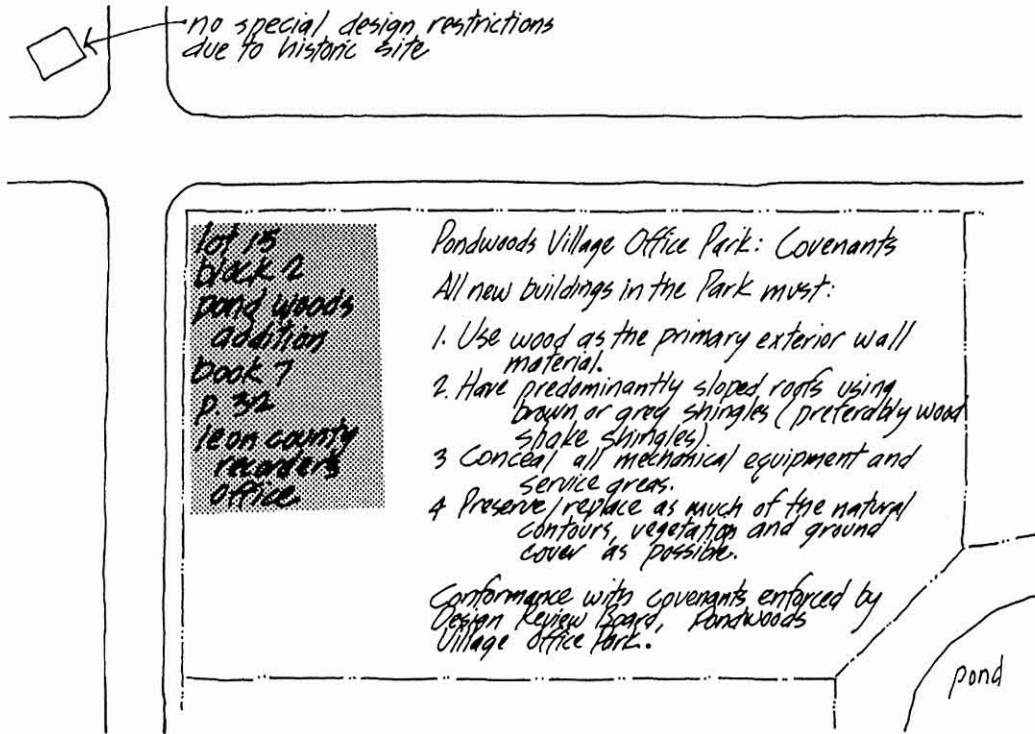

● Ownership and jurisdiction

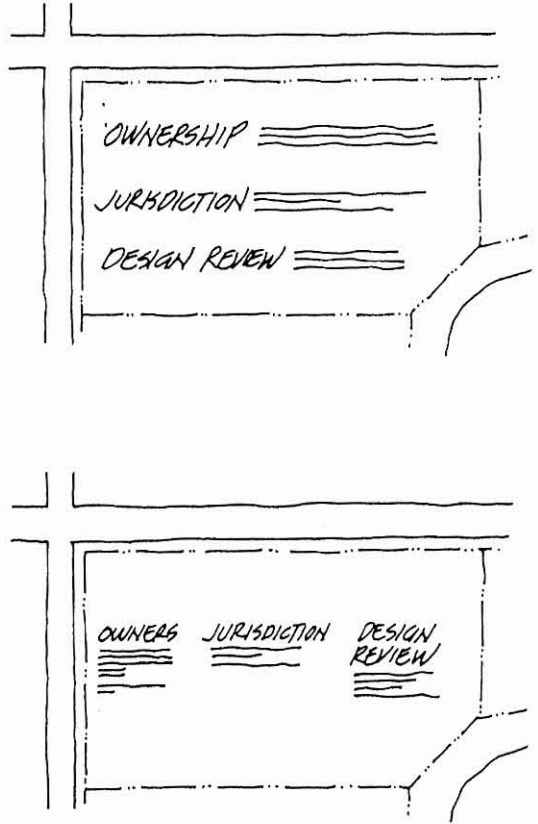
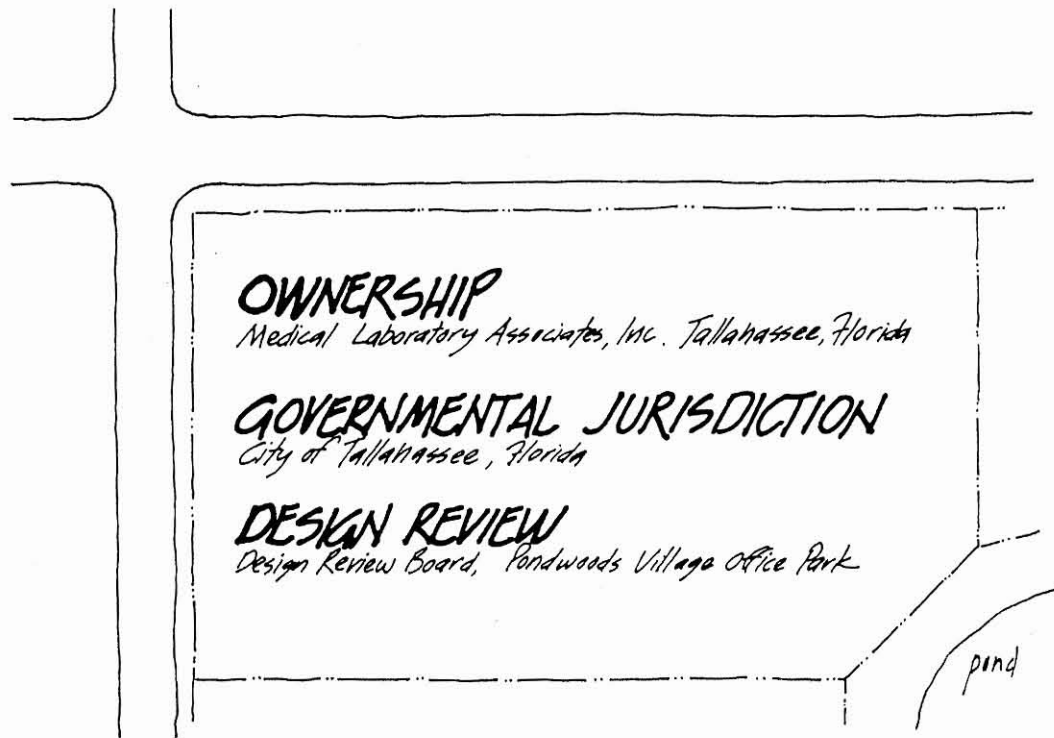

# Natural Physical Features

## ● Contours

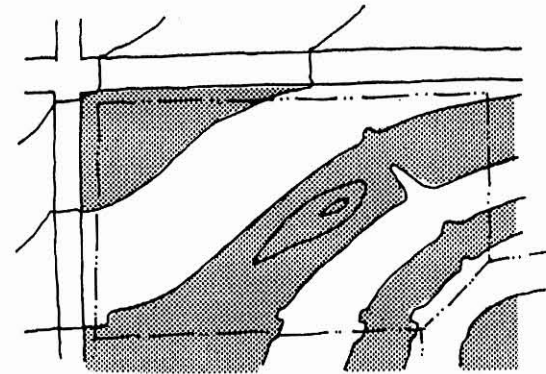
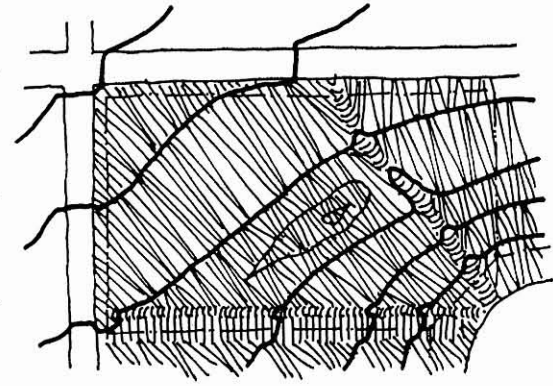
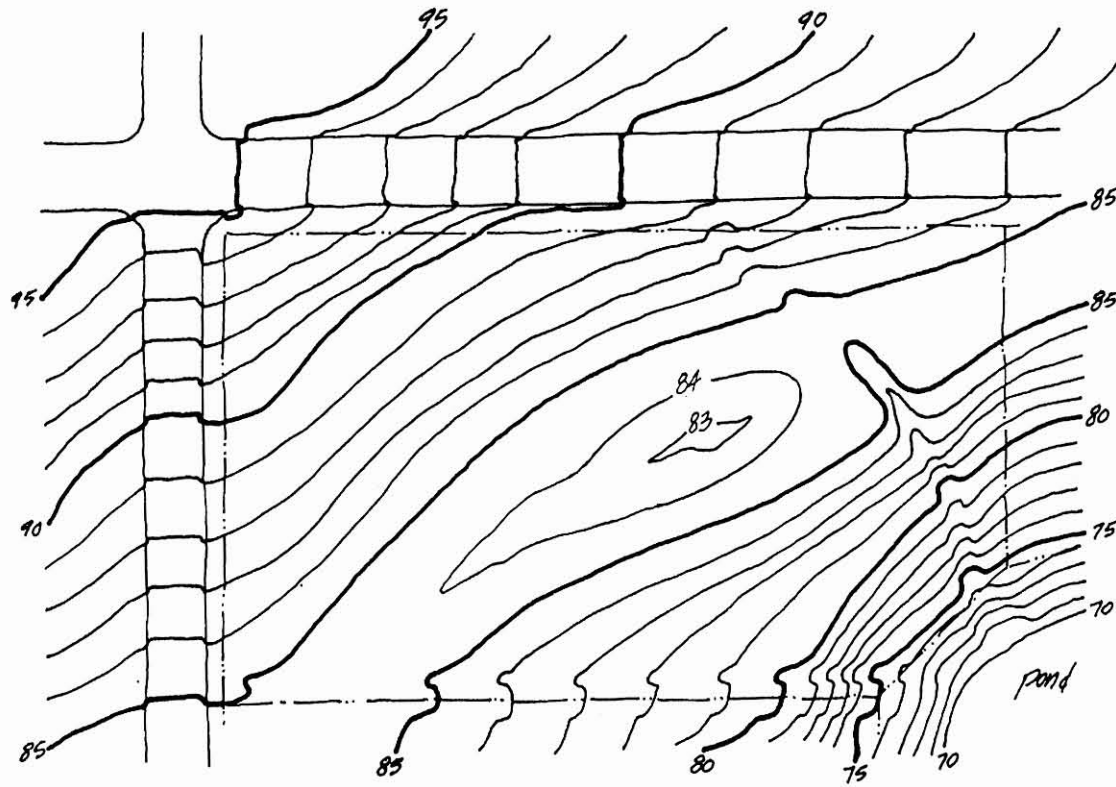

● Major land features

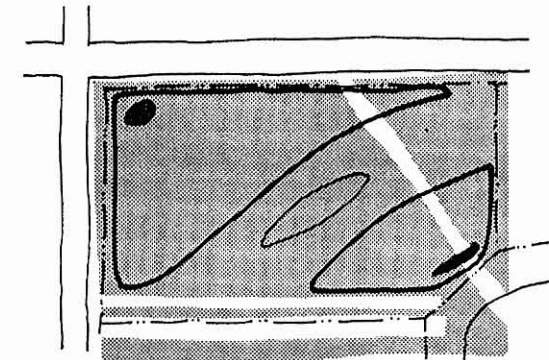
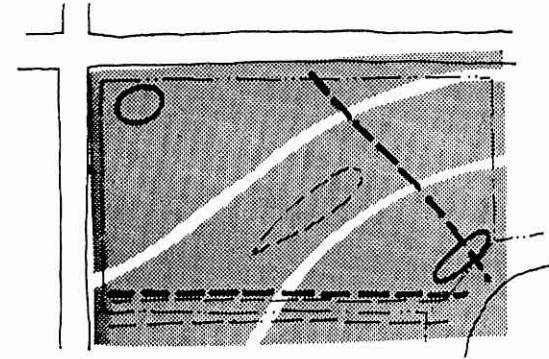
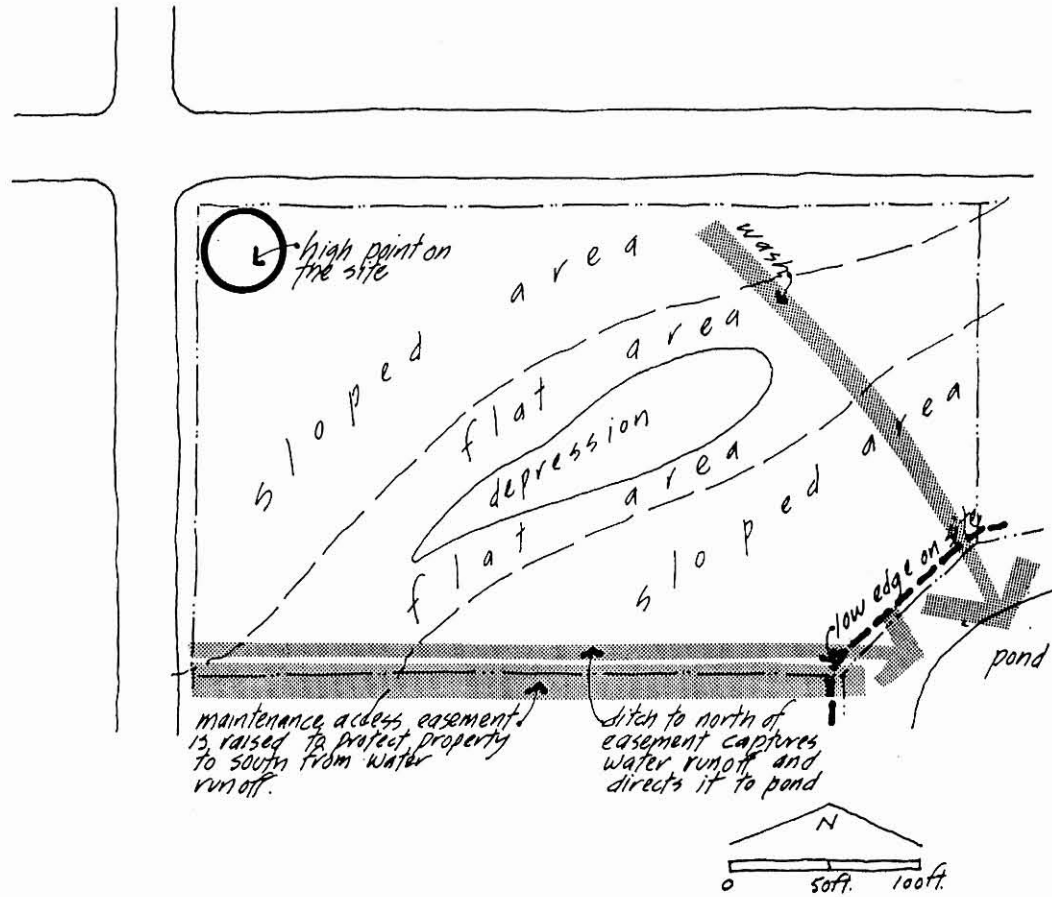

● Slope

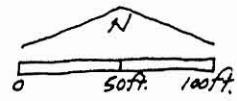
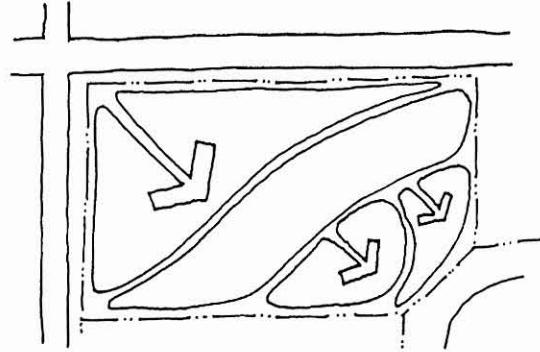
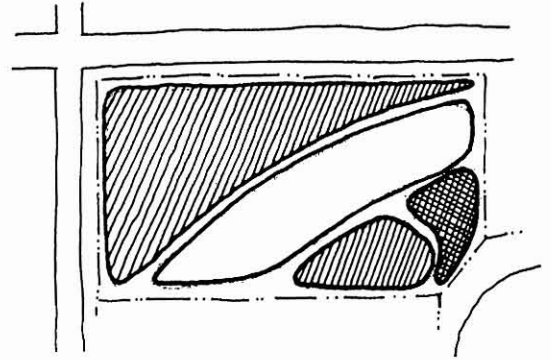
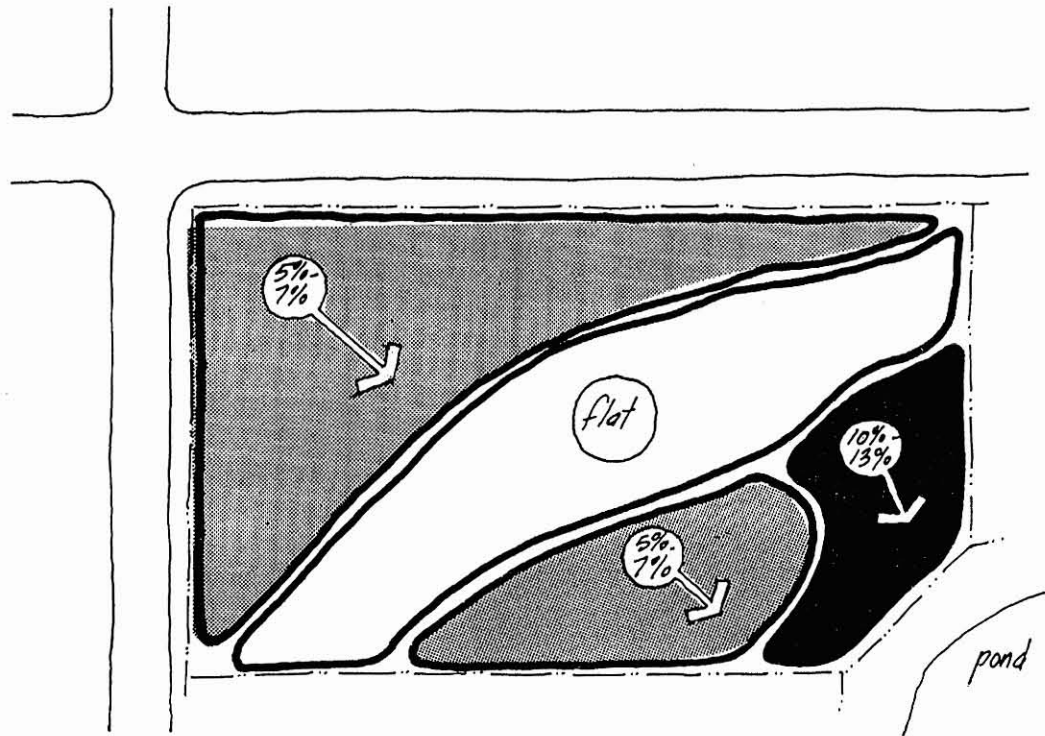

● Surface drainage patterns

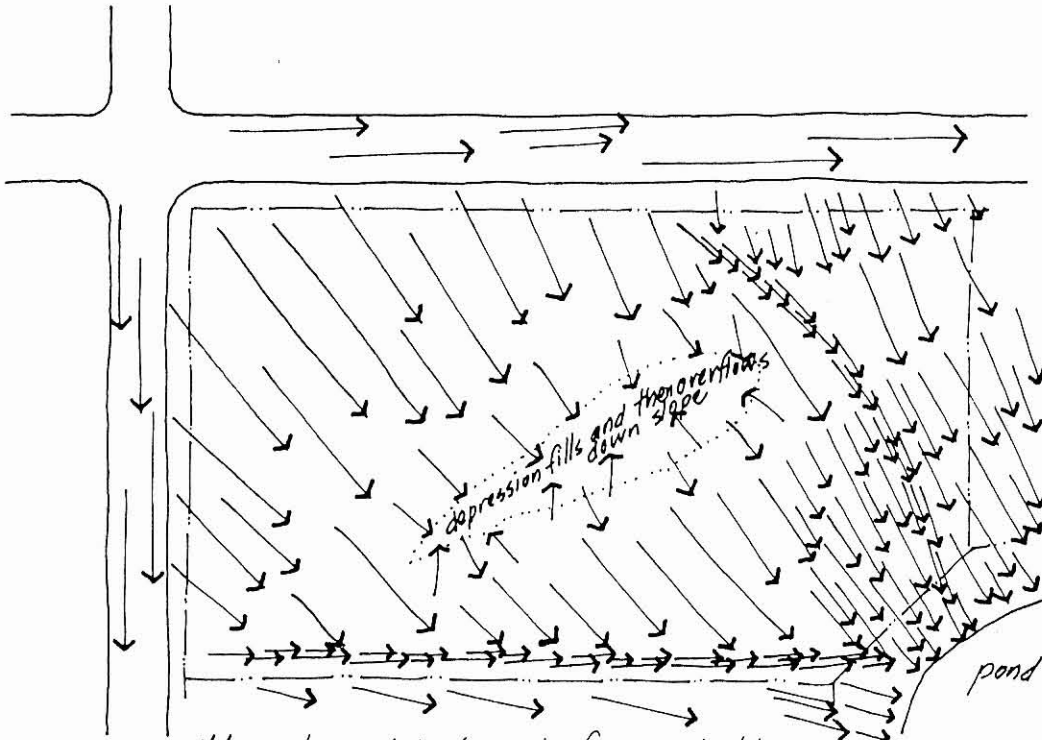

Note: water ponds in depression for approximately 2 days after a rain before drying up.

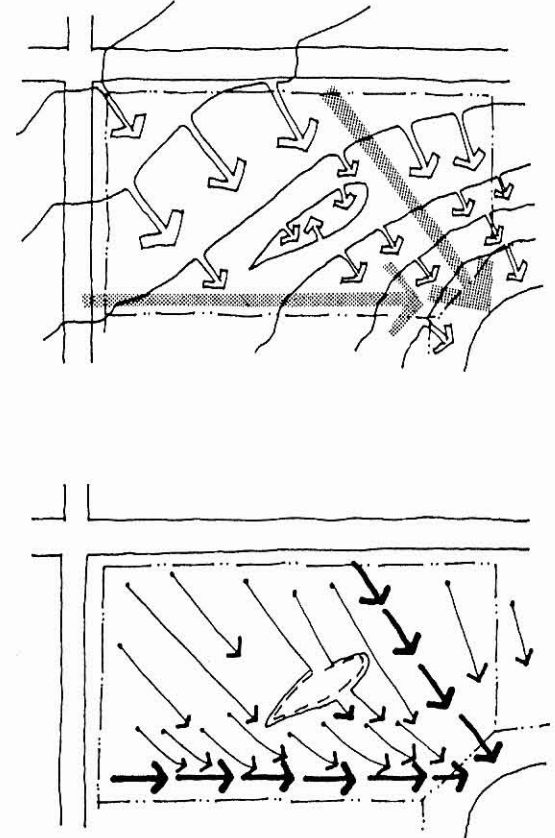

# ● Pond

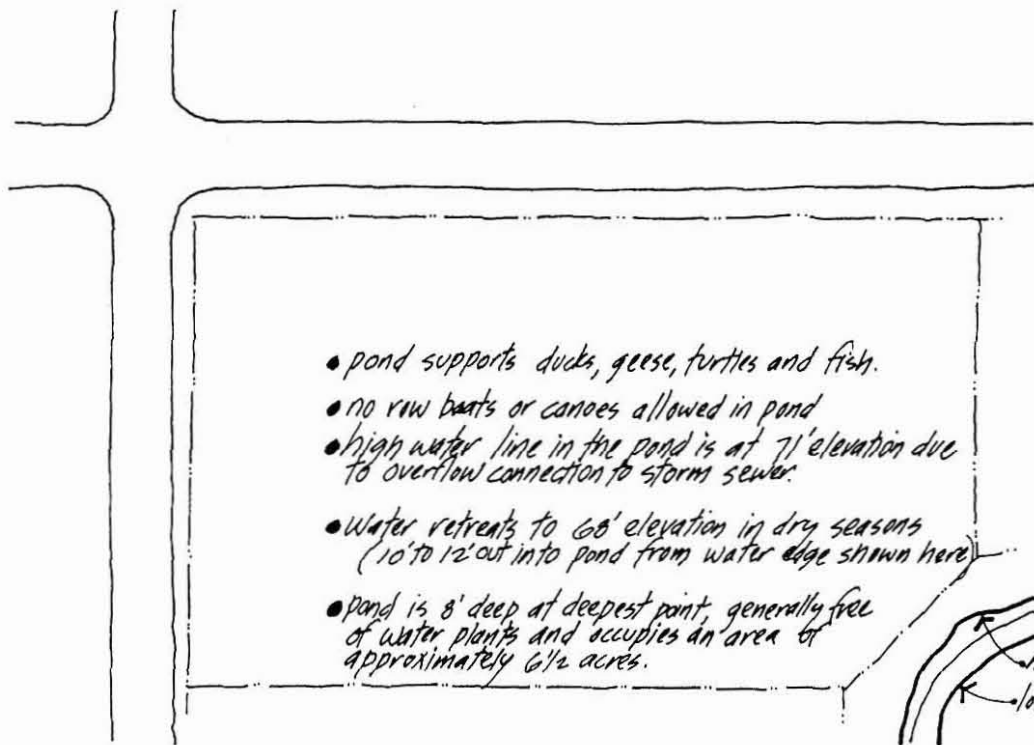

● Ground cover and condition

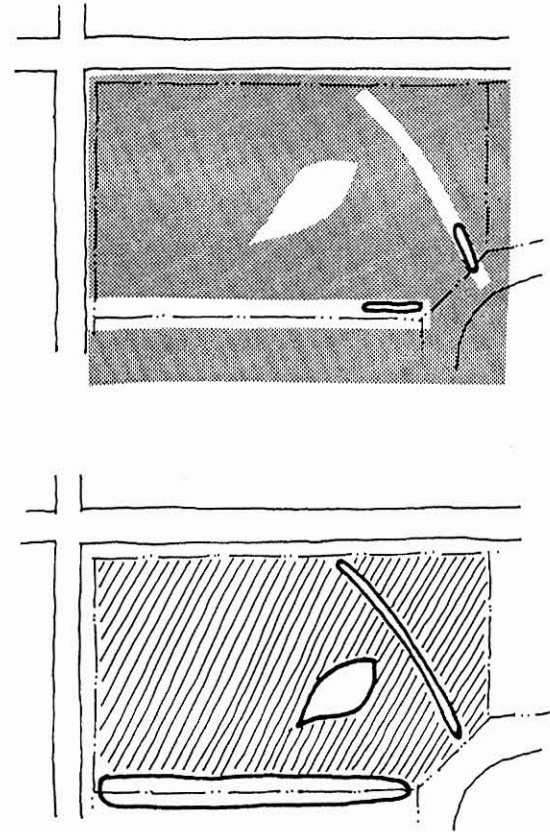
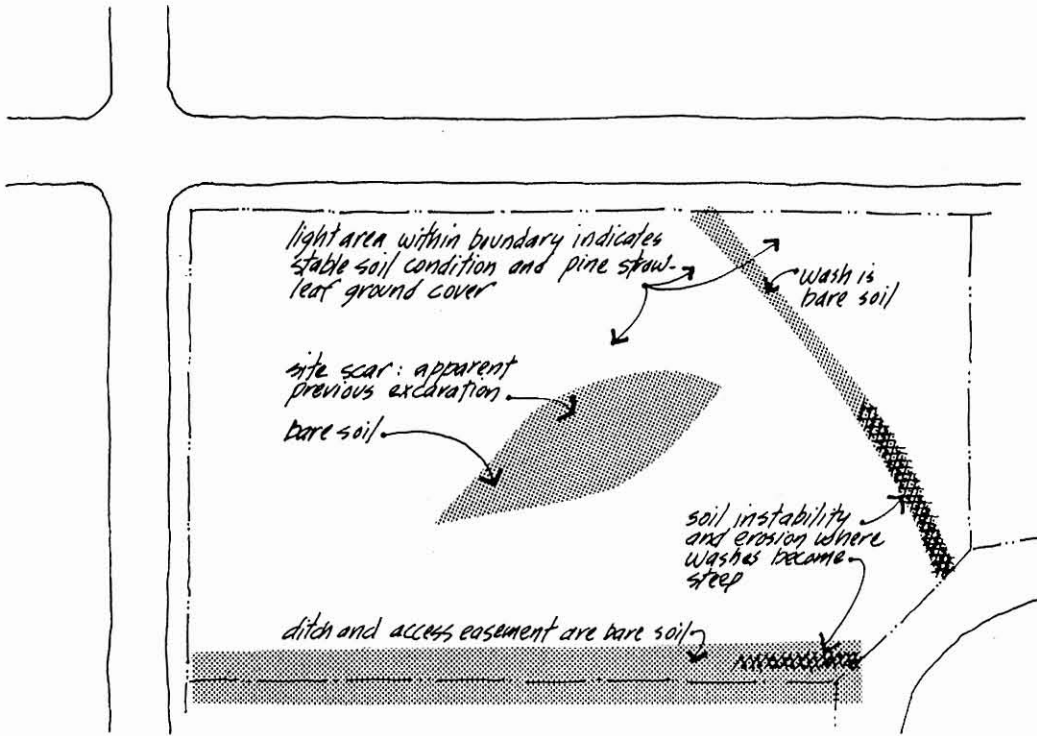



● Soil

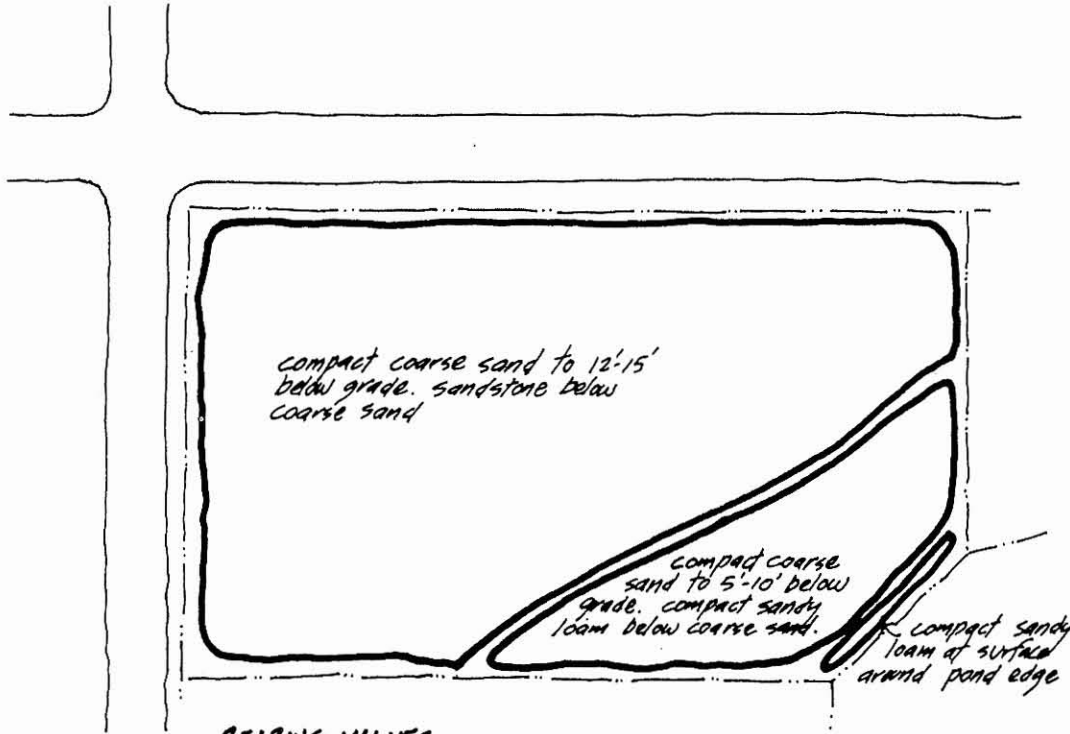

- BEARING VALUES**
- coarse compact sand - 6000 lb/ft<sup>2</sup>
  - compact sandy loam - 2500 lb/ft<sup>2</sup>

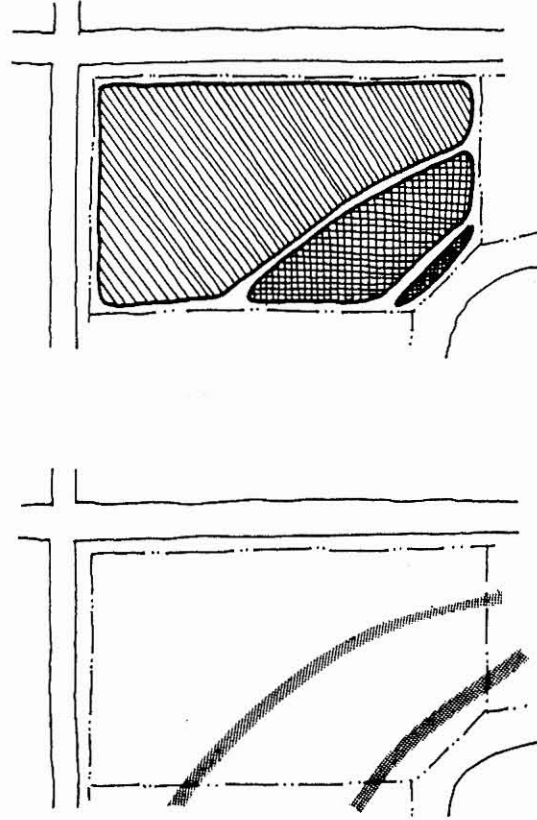

# Vegetation

- 1 40" live oak
- 2 6"-12" pine and scrub oak
- 3 6"-10" dogwood
- 4 4"-6" dogwood
- 5 12"-24" live oak
- 6 6"-12" scrub oak
- 7 bamboo
- 8 sawgrass and low scrub at pond edge

0 25 50 75 100 vertical scale

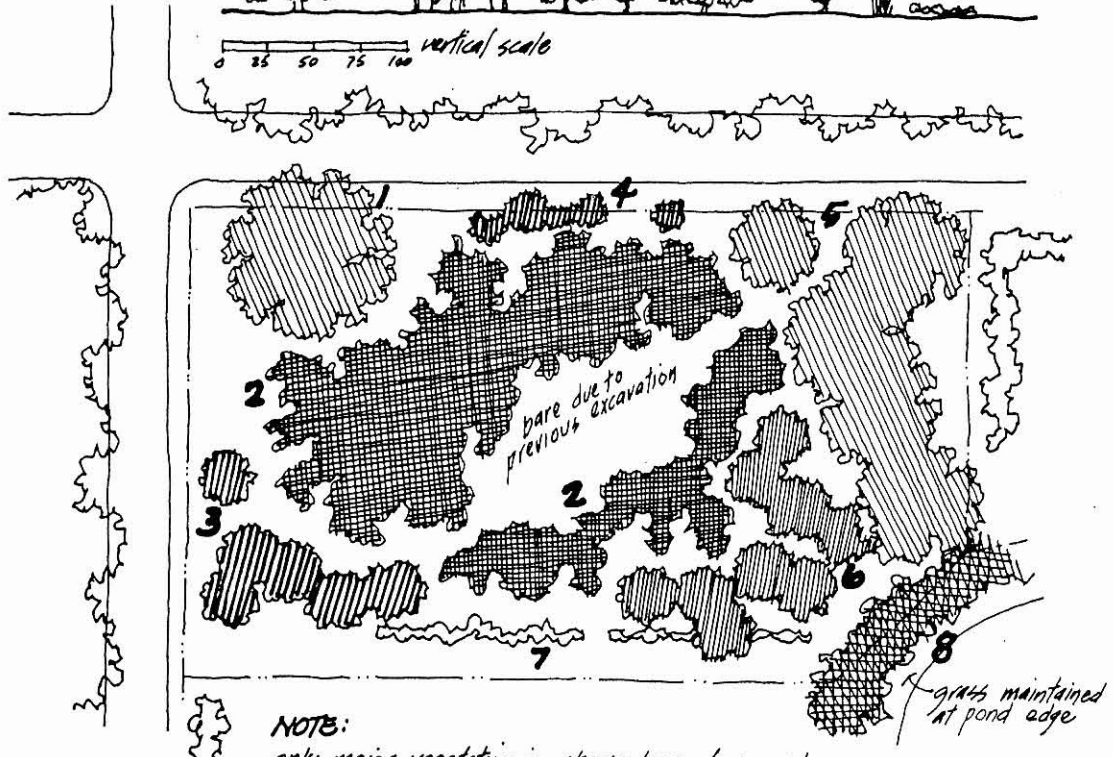

NOTE:  
only major vegetation is shown here. low scrub growth fills most of the white areas on the site drawing

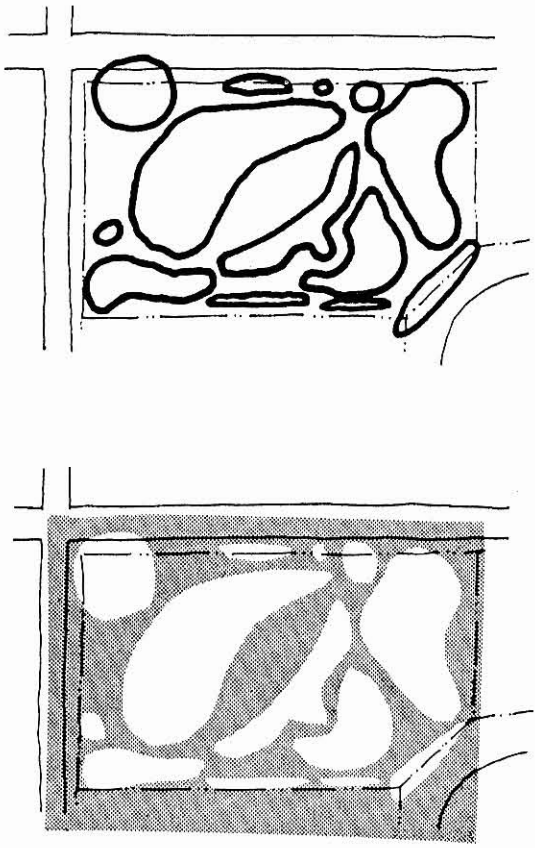

# Man-made Features

## ● On site features

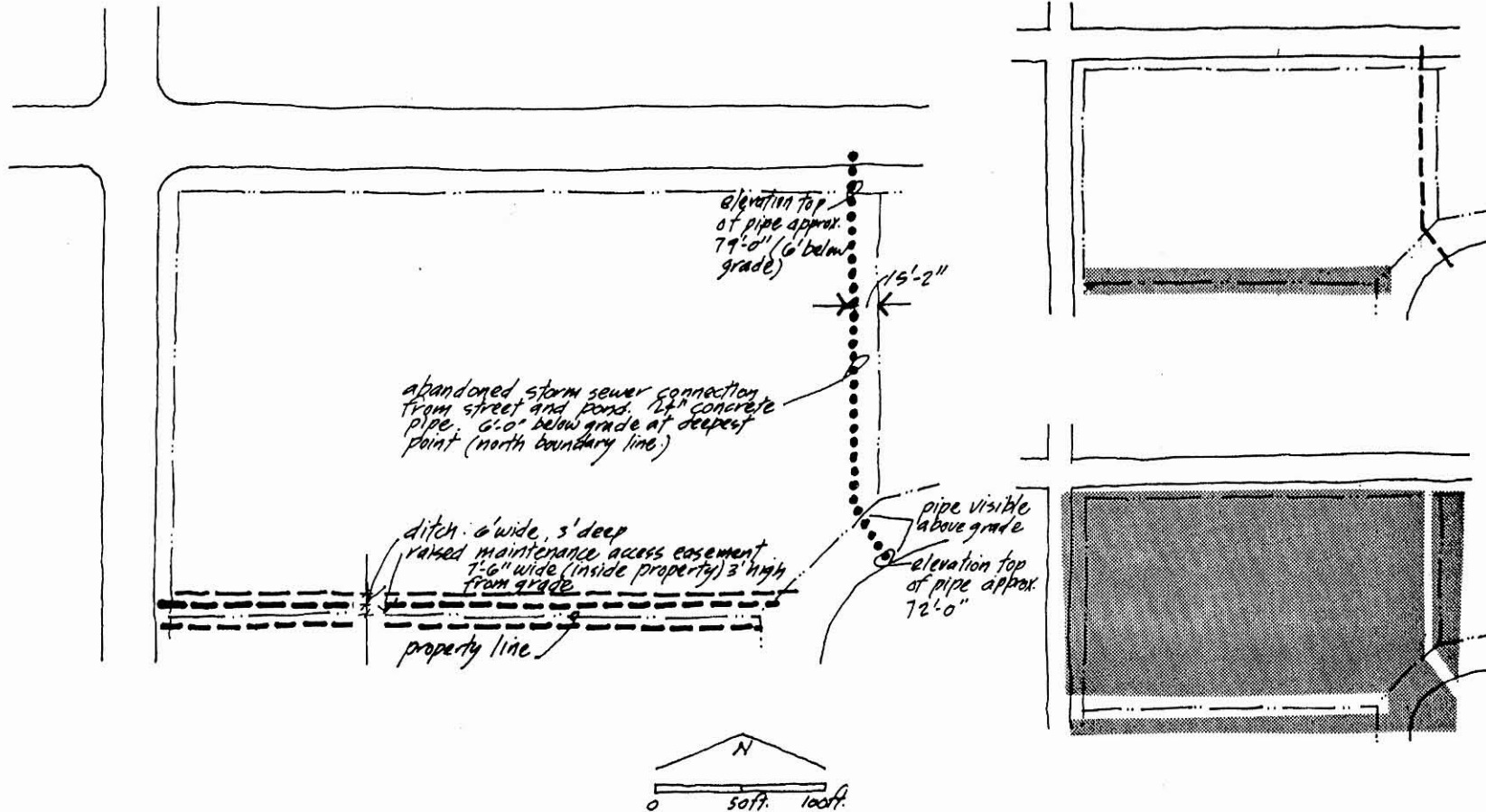

● Off site features

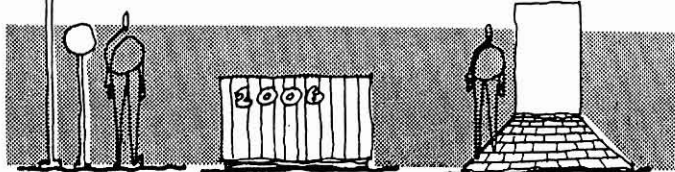
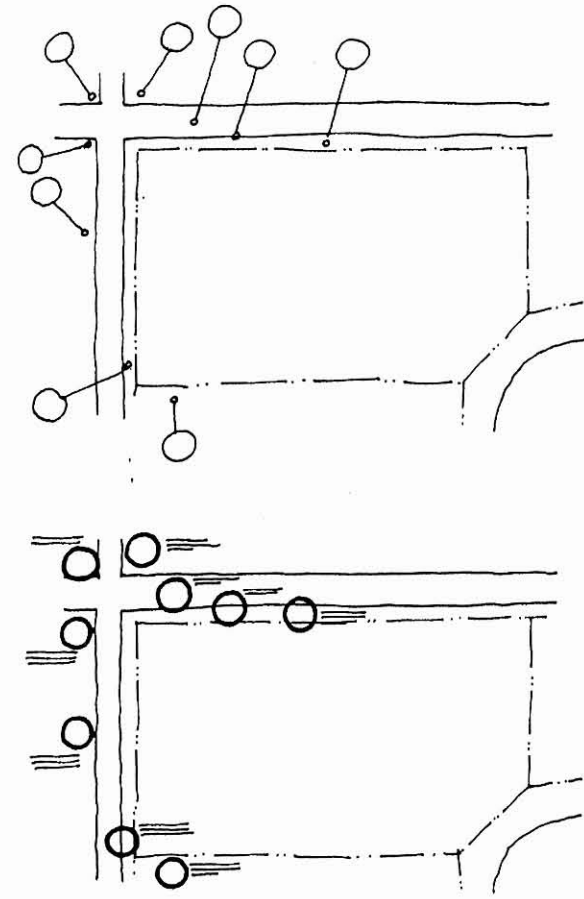
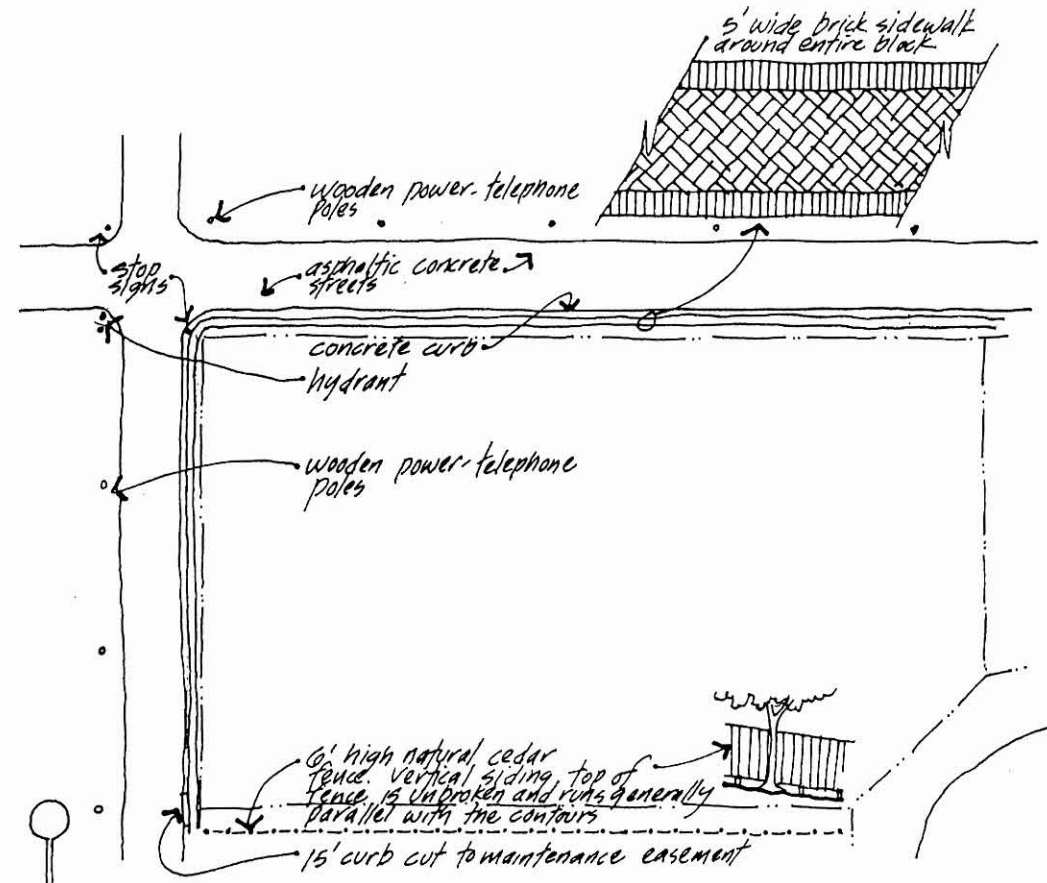

white globe, exterior lights typical

address and business signs are cedar panels

brick walks to building entries

**COMMON DETAILS WITHIN OFFICE PARK**



(see "views from site" for details about adjacent buildings)

● Pedestrian

Circulation

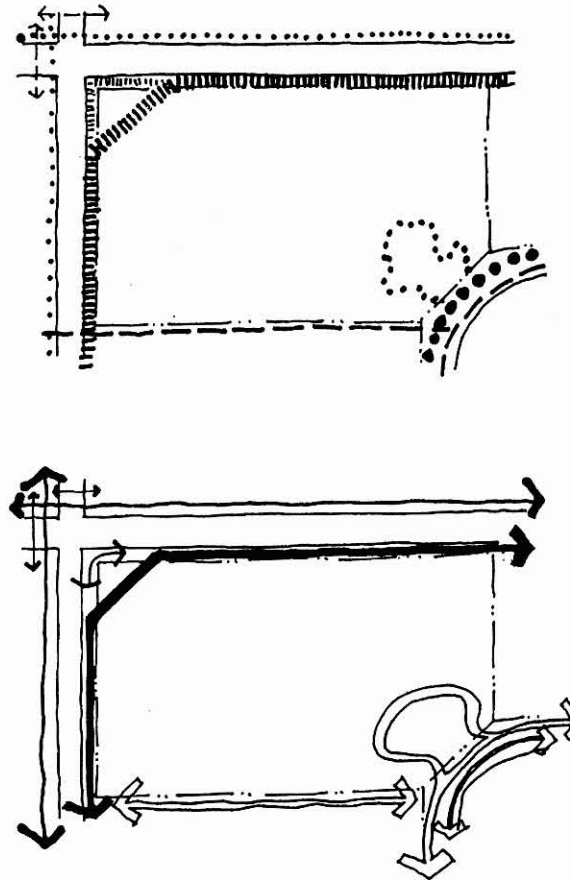
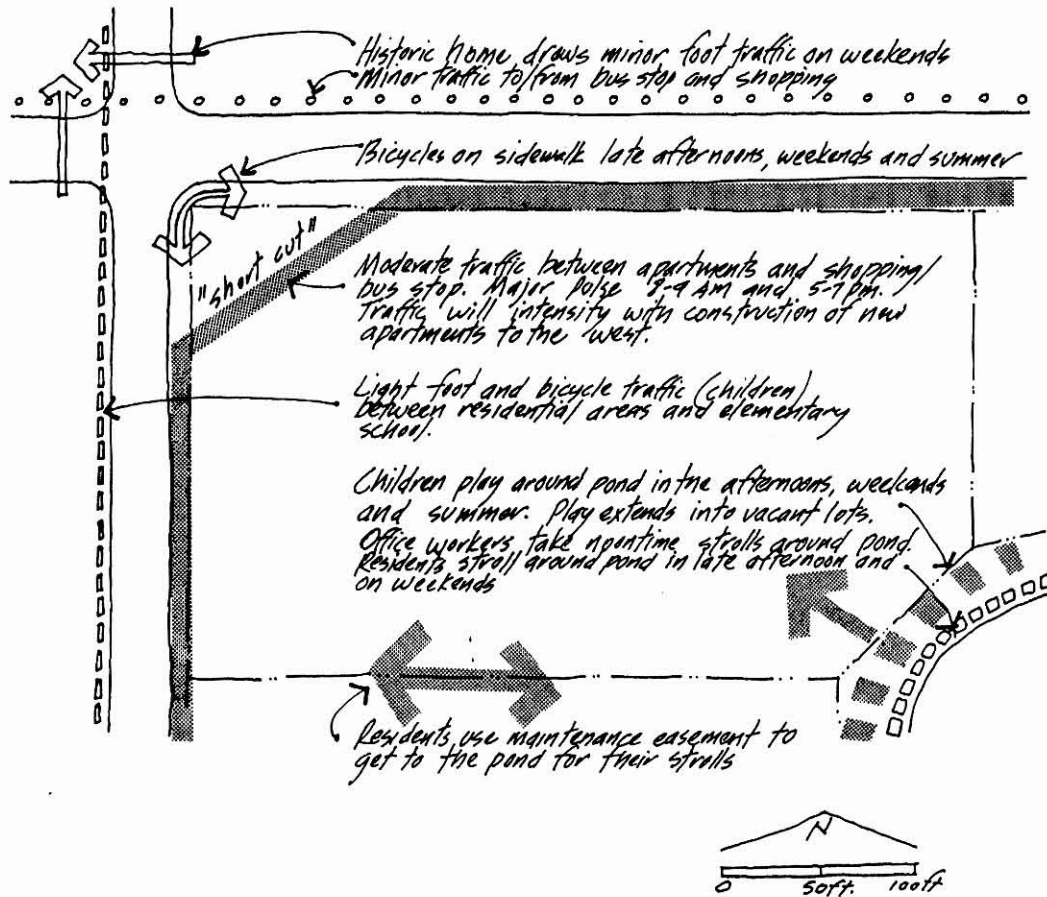

# ● Vehicular

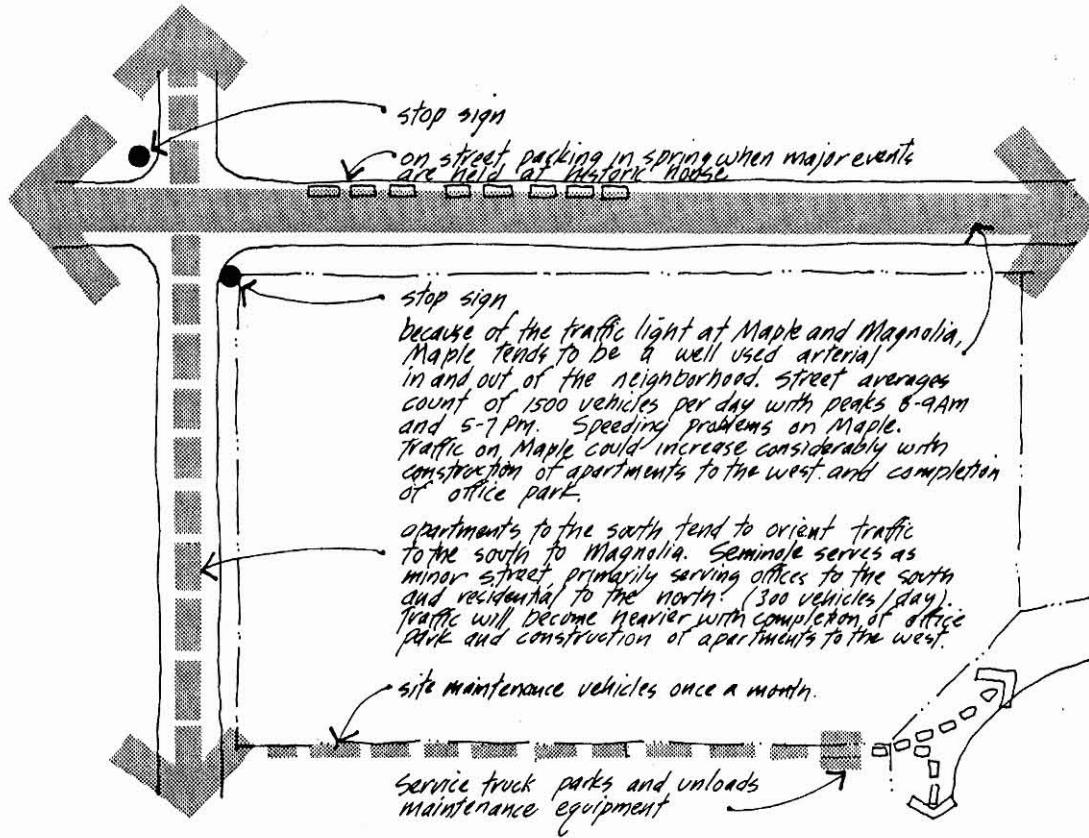

**NOTE:**  
 no future plans exist to widen roads, officially permit on-street parking or change roads to one-way.

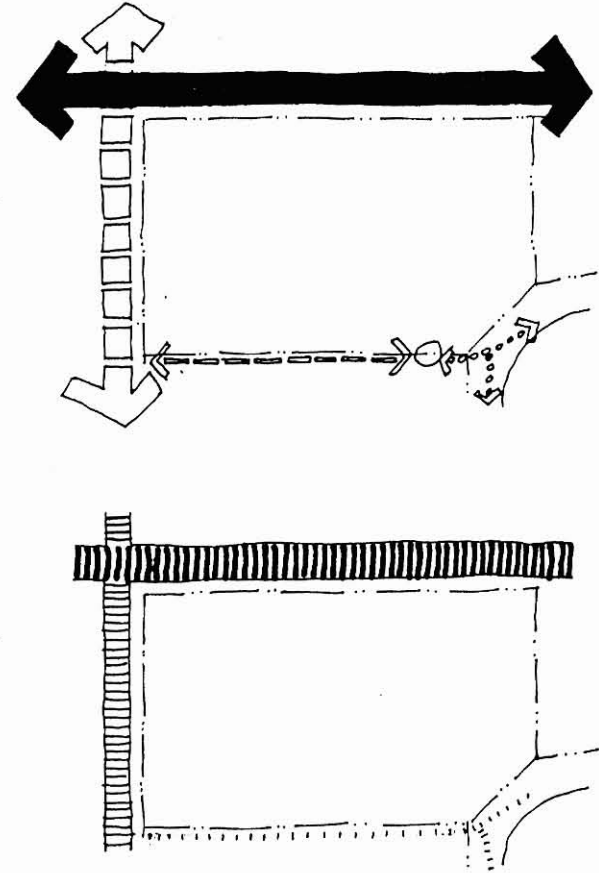

# Utilities

## ● Power, gas and telephone

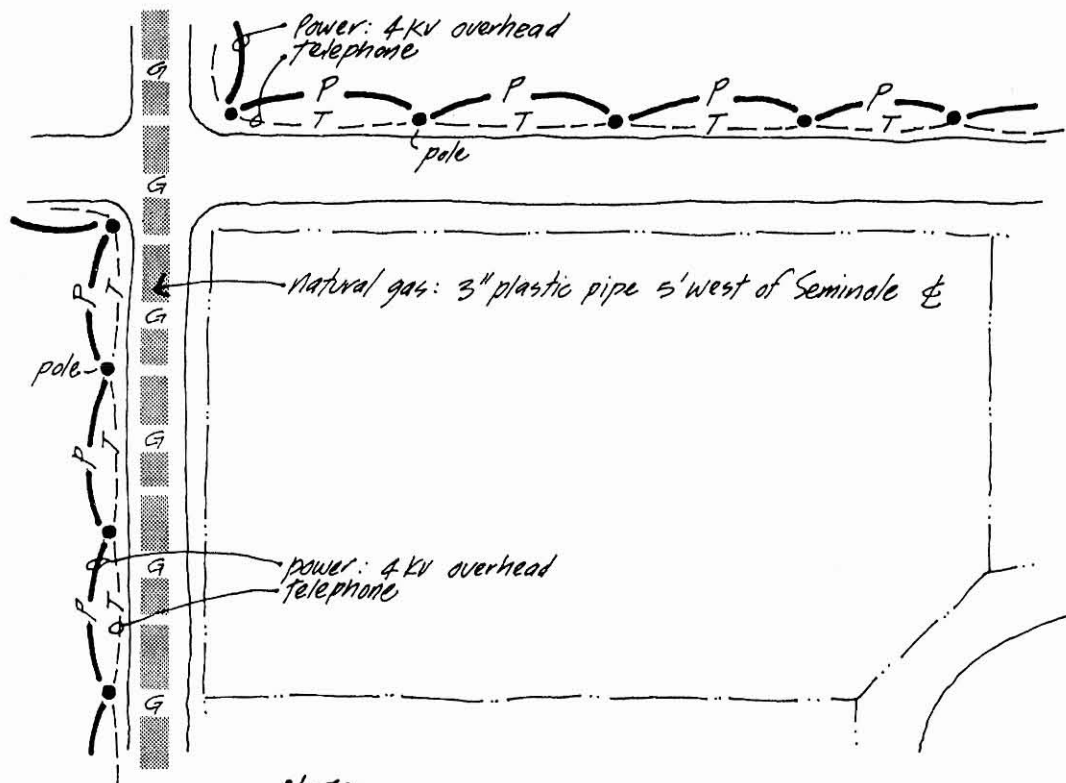

**NOTE:**  
all utilities within Pandwoods Village  
Office Park must be underground

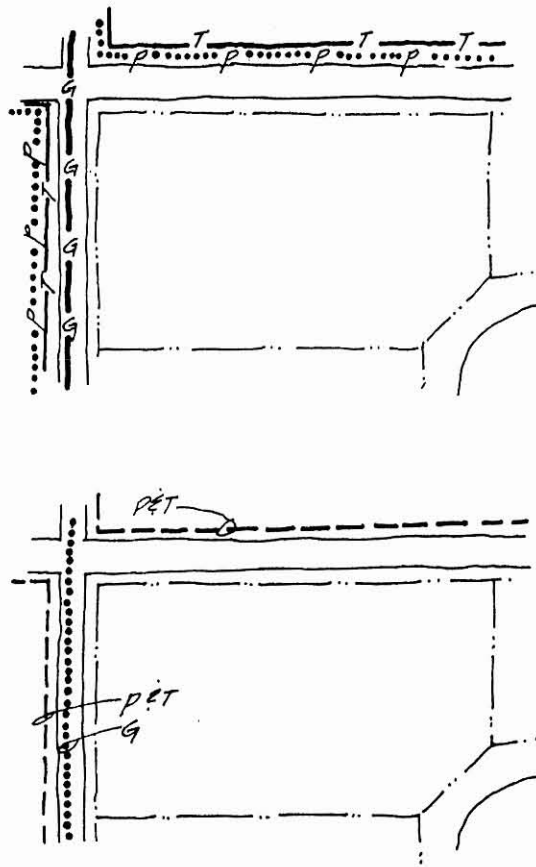

● Water and sewer

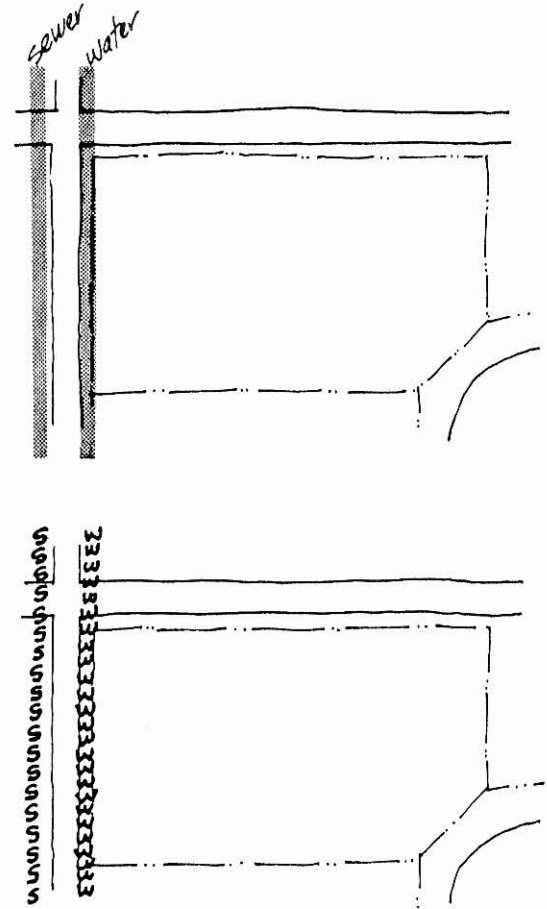
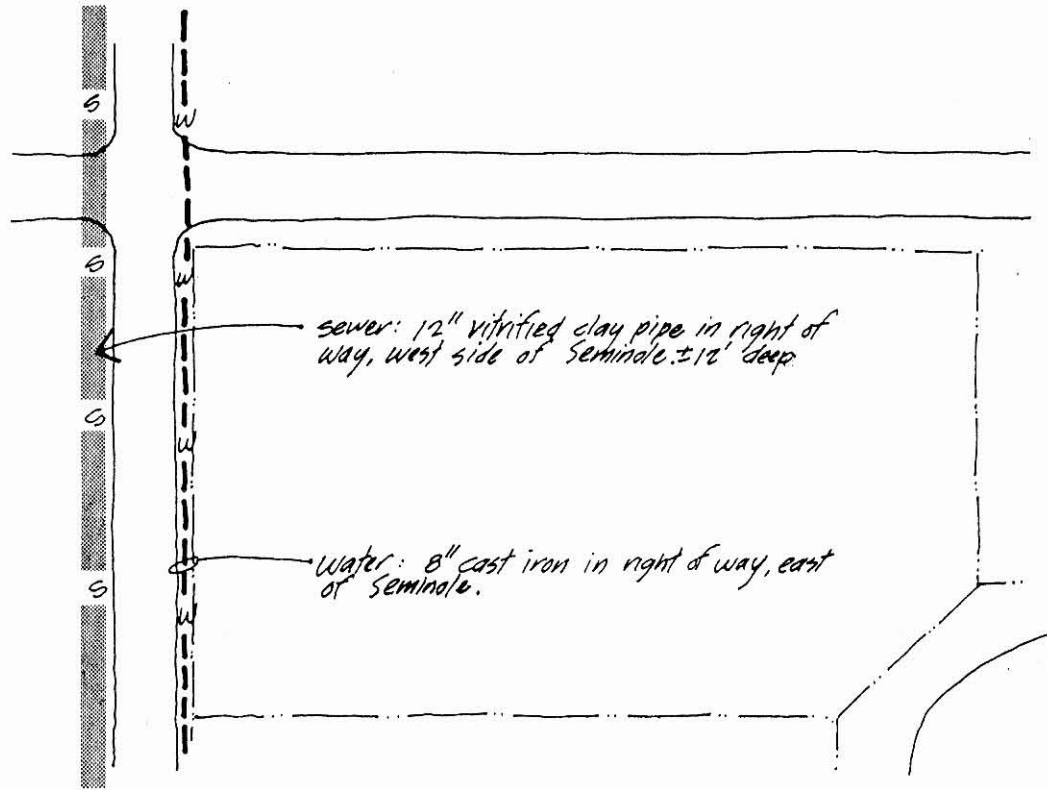



# Sensory

## ● Views into the site

NOTE: width of arrows indicates relative importance of responding to views in design

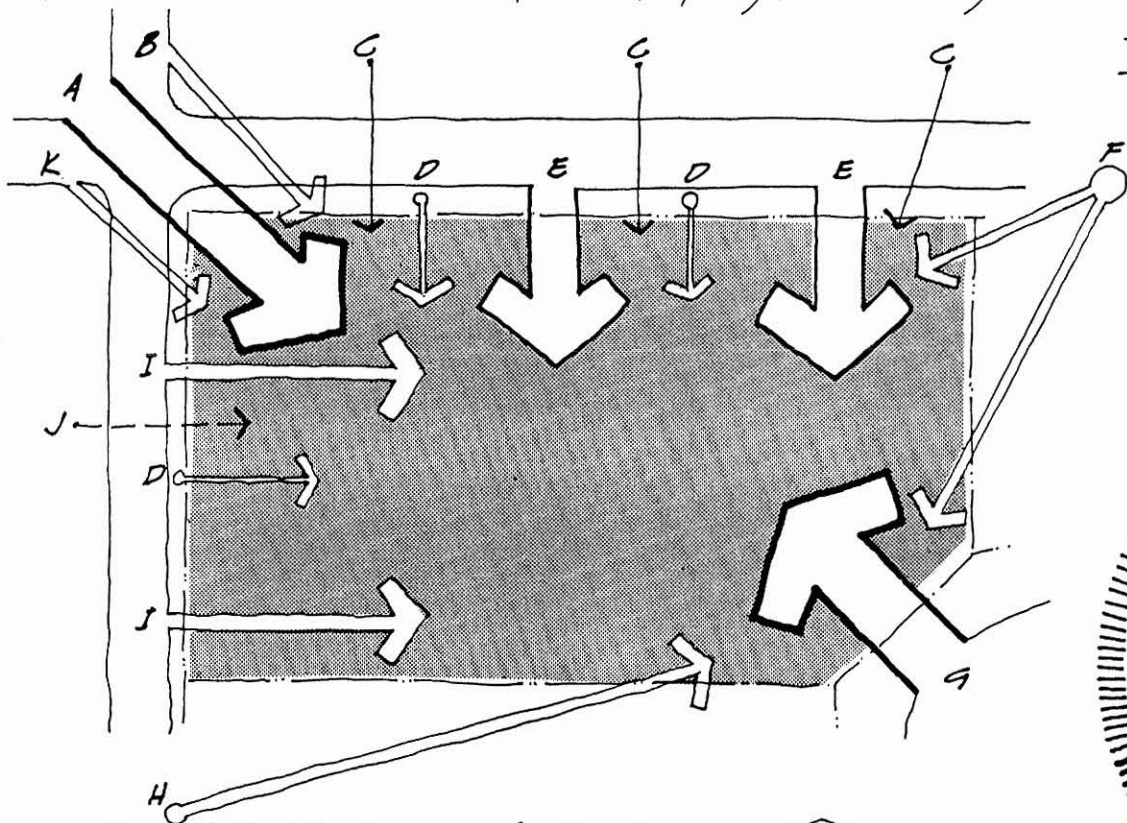

- A. major view to site from historic house.
- B. from vehicular approach down Seminole.
- C. from residences across Maple Drive
- D. from sidewalk
- E. from vehicles on Maple Drive
- F. from vehicular approach down Maple
- G. major view from other buildings across pond
- H. glimpse over fence from sidewalk and Seminole
- I. from Seminole
- J. future view from property across Seminole
- K. from vehicular approach on Maple

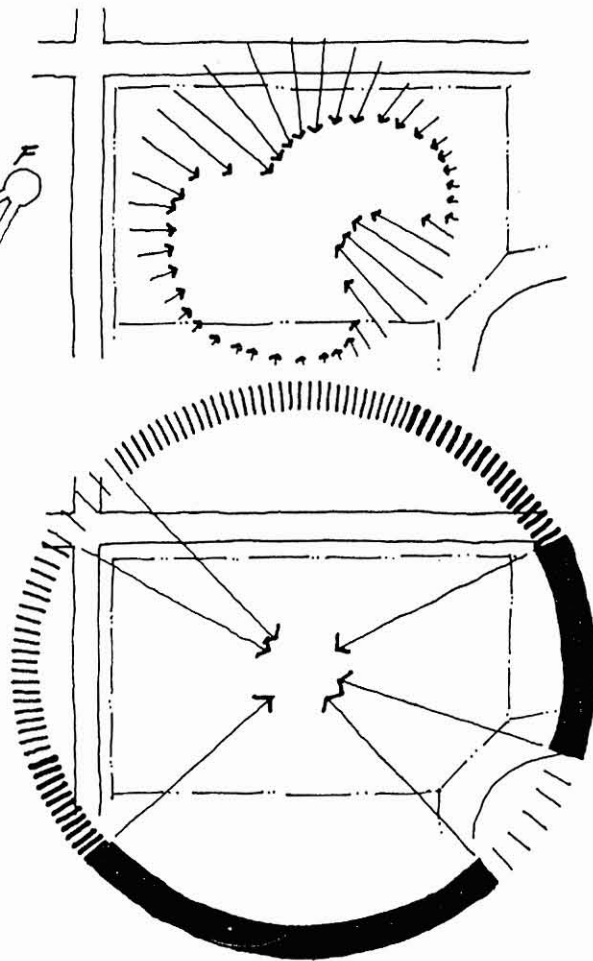

● Views from the site

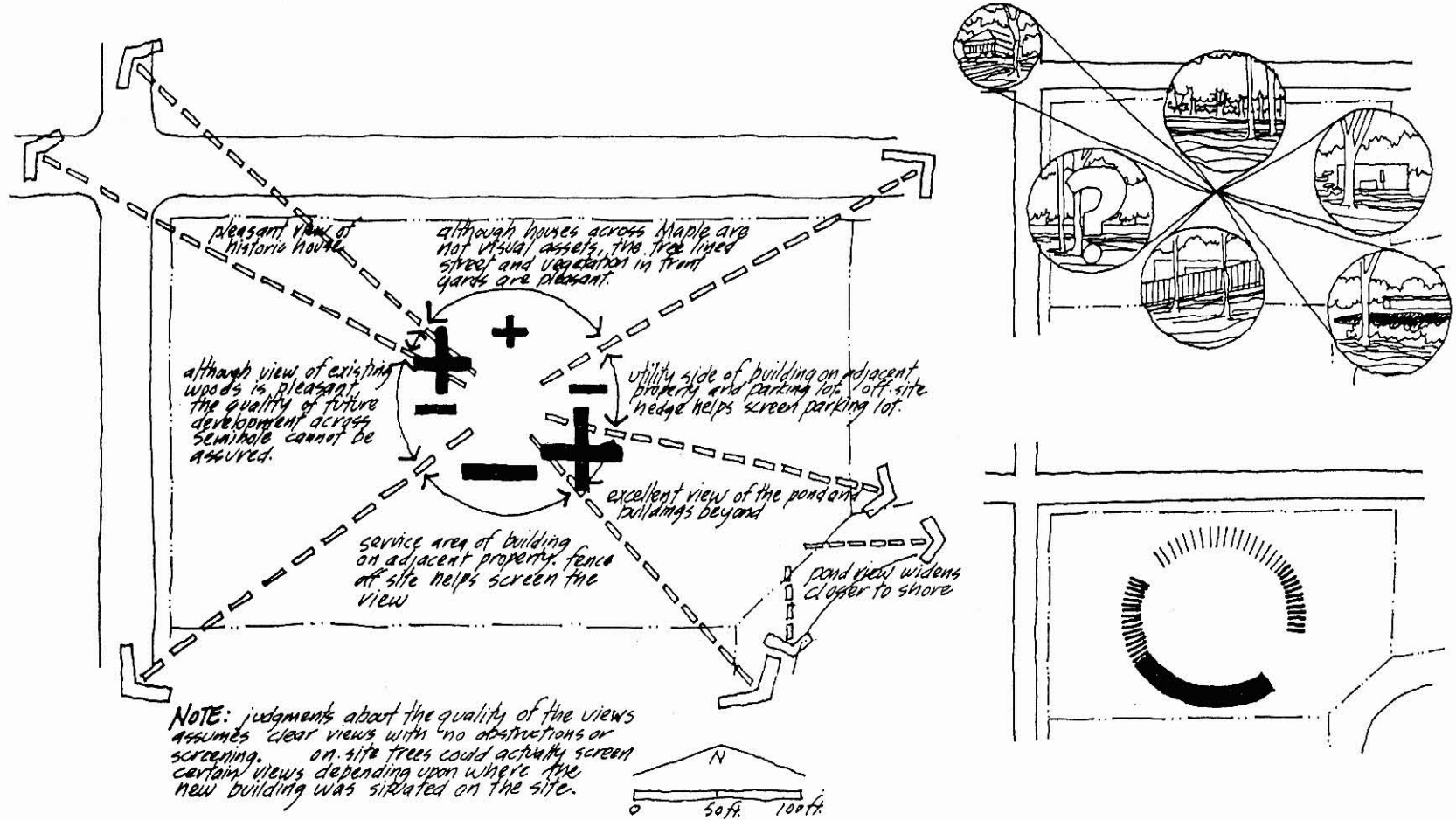

# ● View quality from various site positions

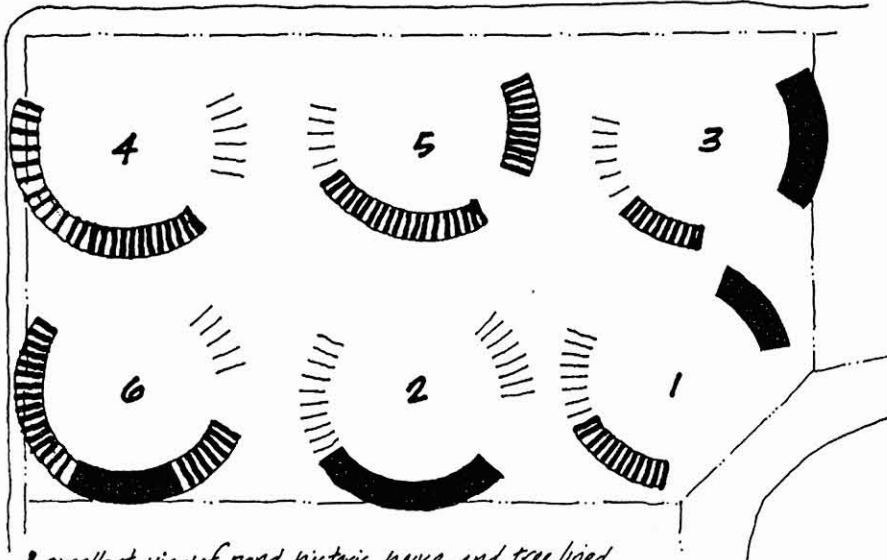
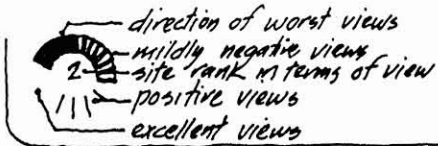

- 1 excellent view of pond, historic house and tree lined Maple Drive. proximity to fence screens adjacent building to south.
- 2 excellent for view to south, good views in all directions. restricted view of pond.
- 3 good view down the pond and proximity to tree lined Maple Drive.
- 4 good view of historic house & Maple Drive. pinched view of the pond due to buildings.
- 5 high elevation presents view of service yard to south.
- 6 good view direction restricted to north east. pinched view of pond and historic house.

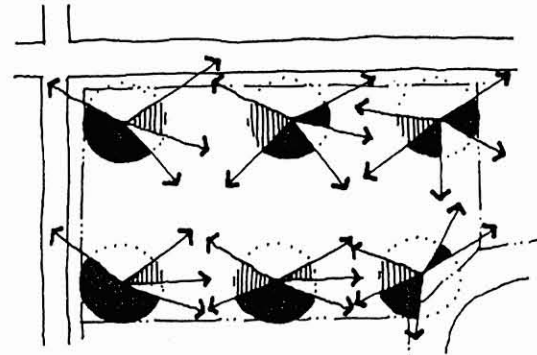
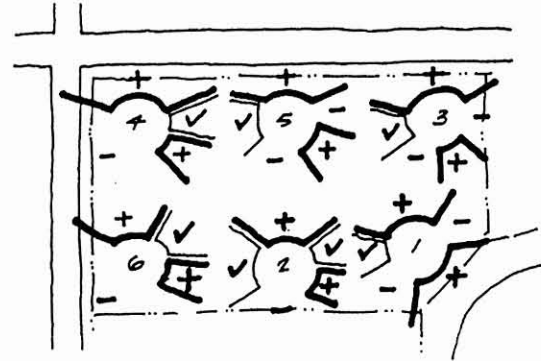
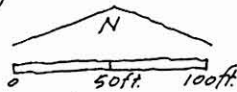

● Points of interest on site

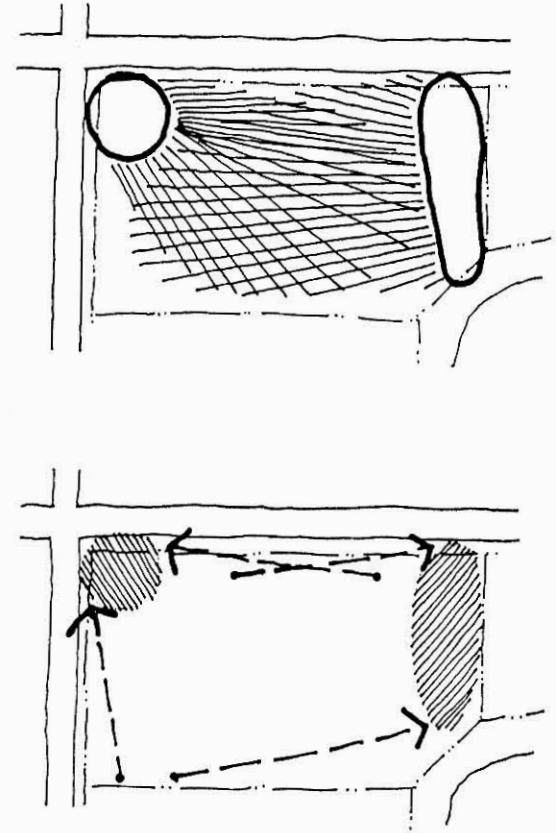
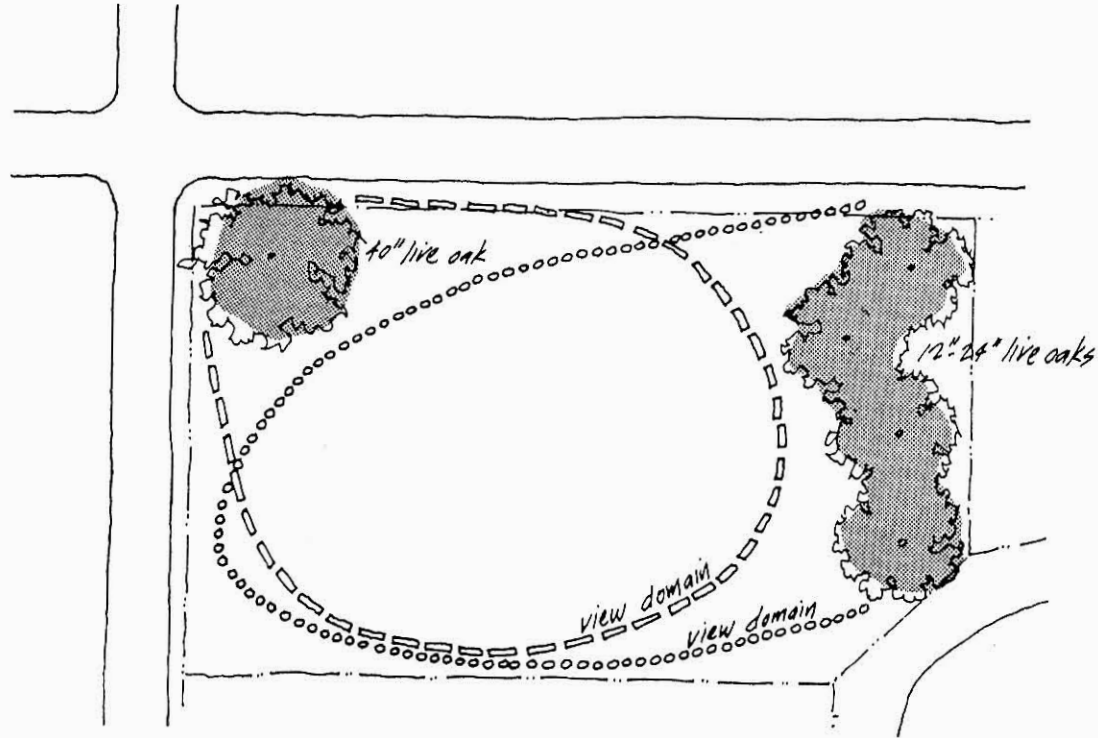

● Views through site

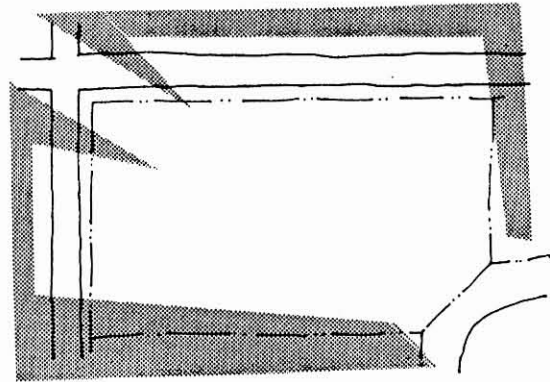
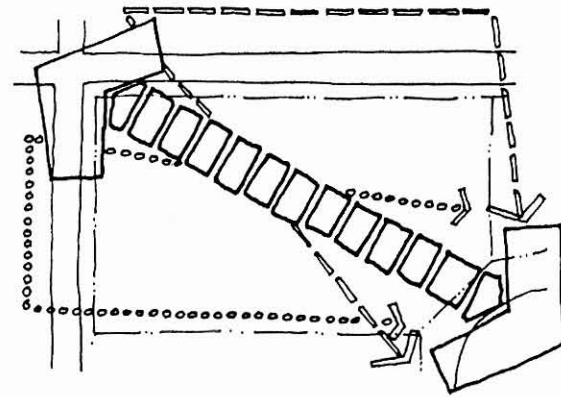
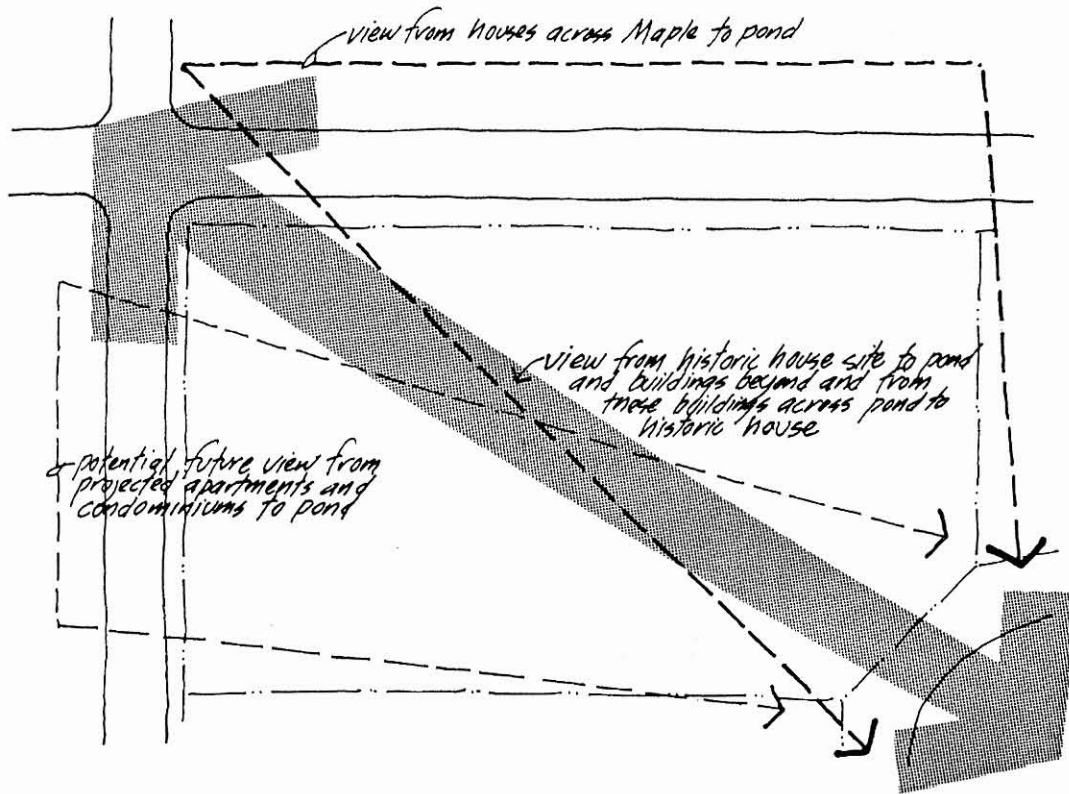

# ● Noise

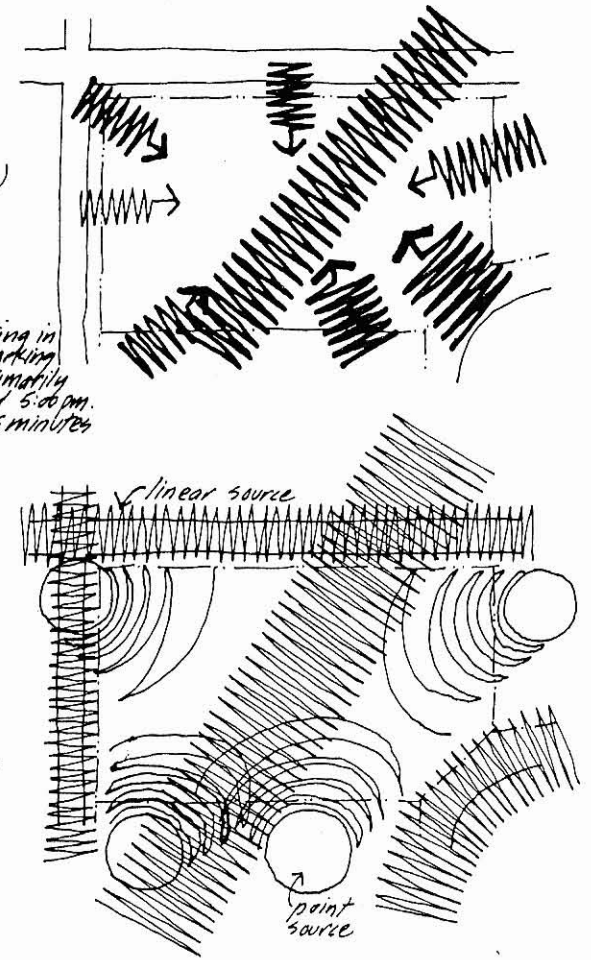
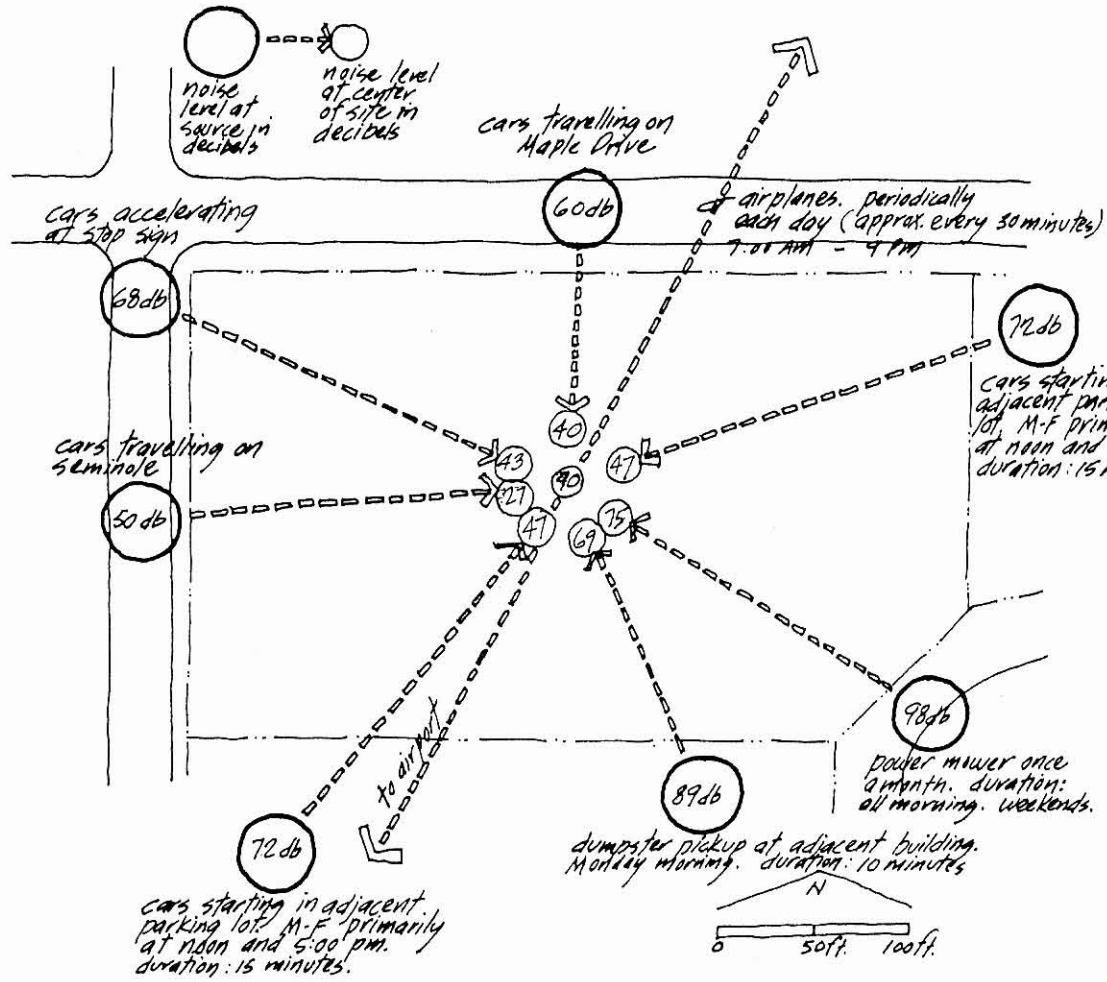

# ● Airborne pollutants

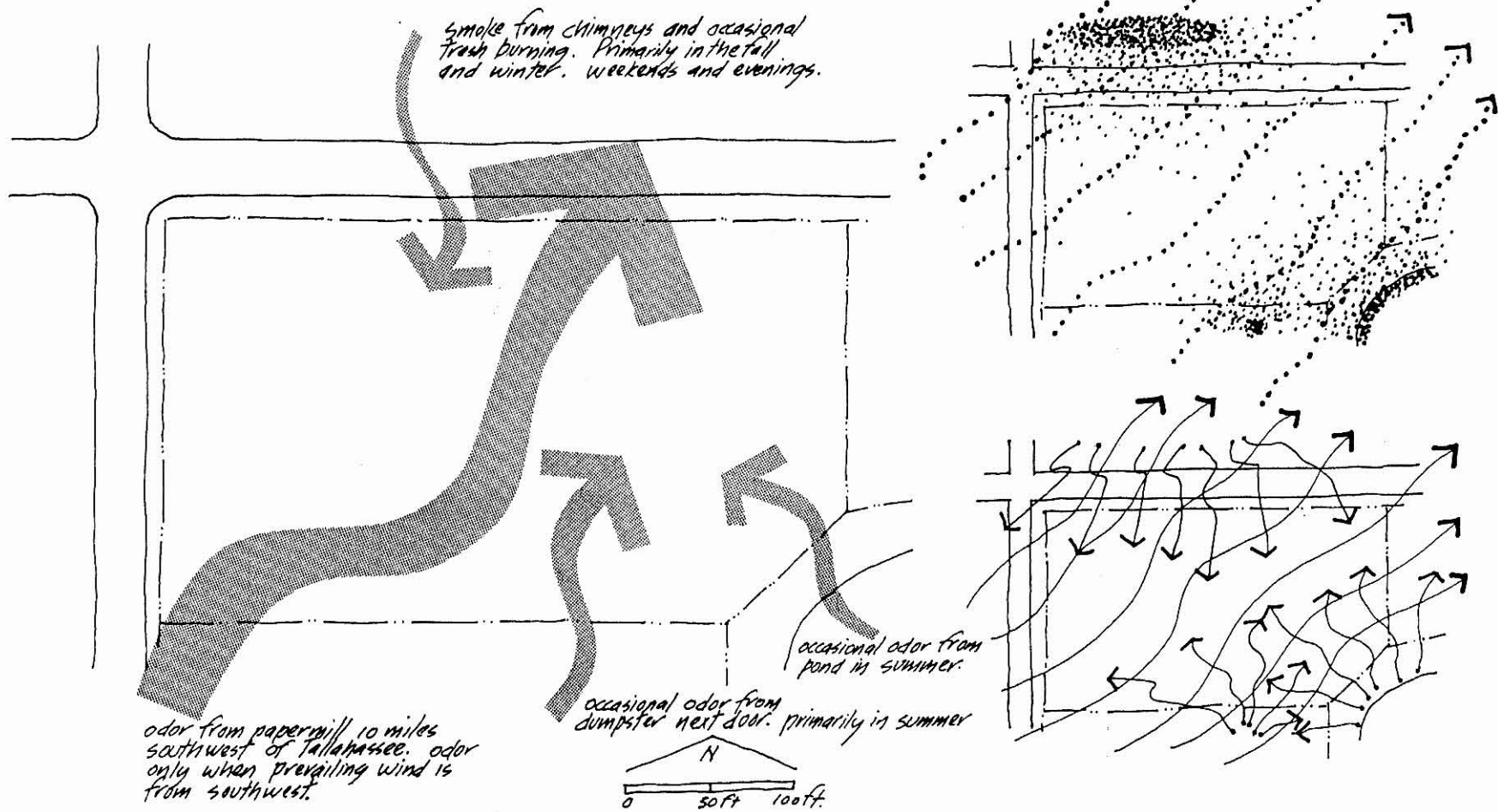

# Human and Cultural

## ● Neighborhood population

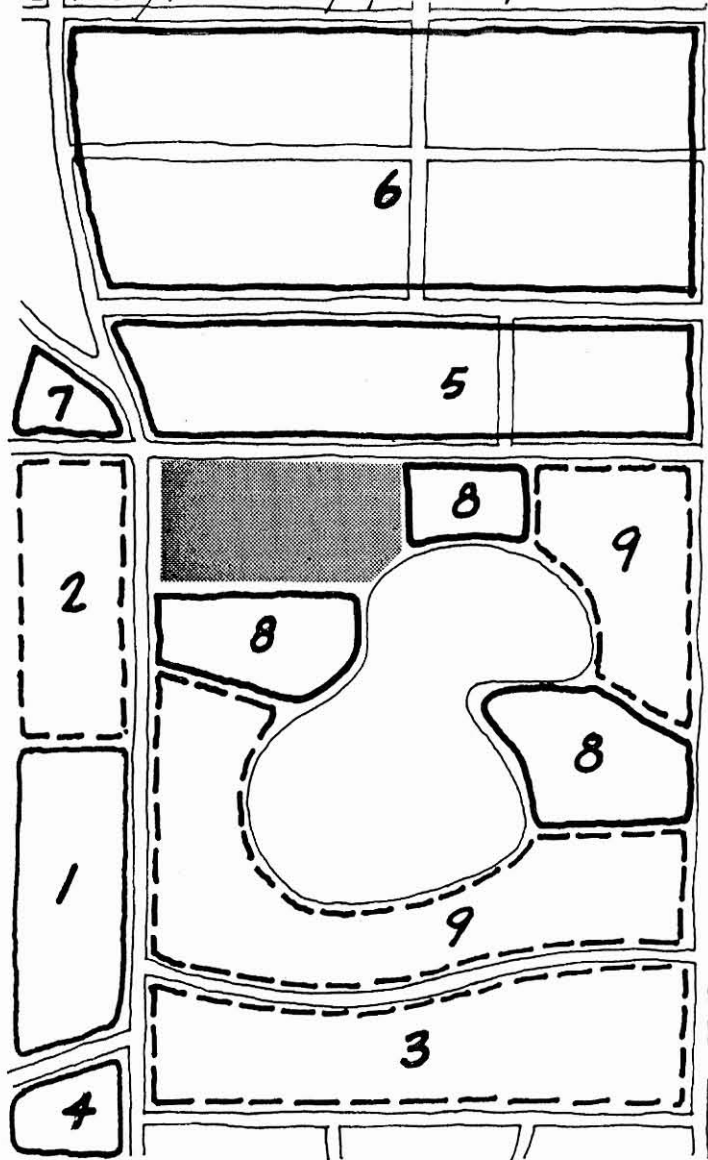

1. Most apartment residents are in upper-middle income range. About 1/2 the residents are families with children ages 3-10. About 1/4 the residents are a mixture of young singles, elderly and middle age marrieds with no children at home. No apparent ethnic patterns. Large percentage of residents work. Many residents use the pond and neighborhood for walks. These characteristics will remain relatively stable with a gradual trend toward young singles.

2. Future apartments will probably house a population similar to that described in #1 above.

3. Future development likely to be townhouse condominiums. Will probably be expensive and thus house middle age to elderly population. Few children anticipated.

4. Apartments are owned and operated by the Presbyterian Church. House retired elderly residents. Residents like to stroll around the neighborhood. No projected changes.

5. Single family residences housing middle income population. Most residents are married and have teen age children living at home. Stable area in terms of housing turnover.

6. Younger population with more young children than in #5. More population turnover than in #5.

7. City Preservation Group very active and effective in Tallahassee. Site and historic house very well maintained. Good relationship with the neighborhood. Two festivals per year (mid-summer and Christmas).

8. Offices contain a range of professional services (insurance, real estate, dentists, engineers, etc). Considerable use of the office park grounds at lunch time.

9. Patterns will be similar to those in #8 above.

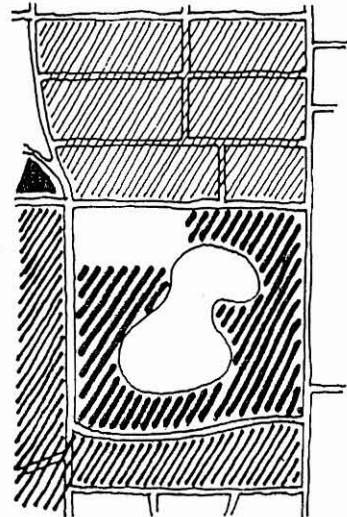
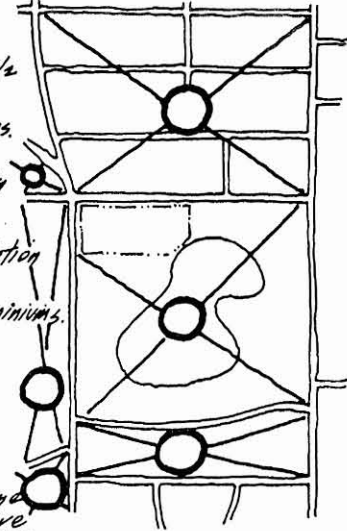
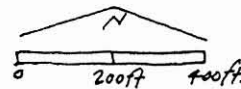



● Negative activity

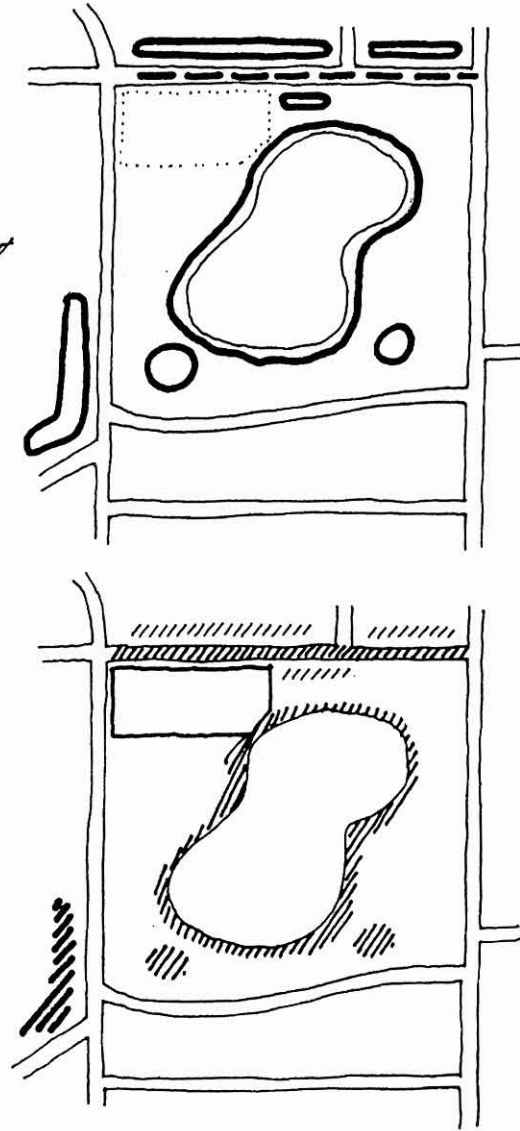
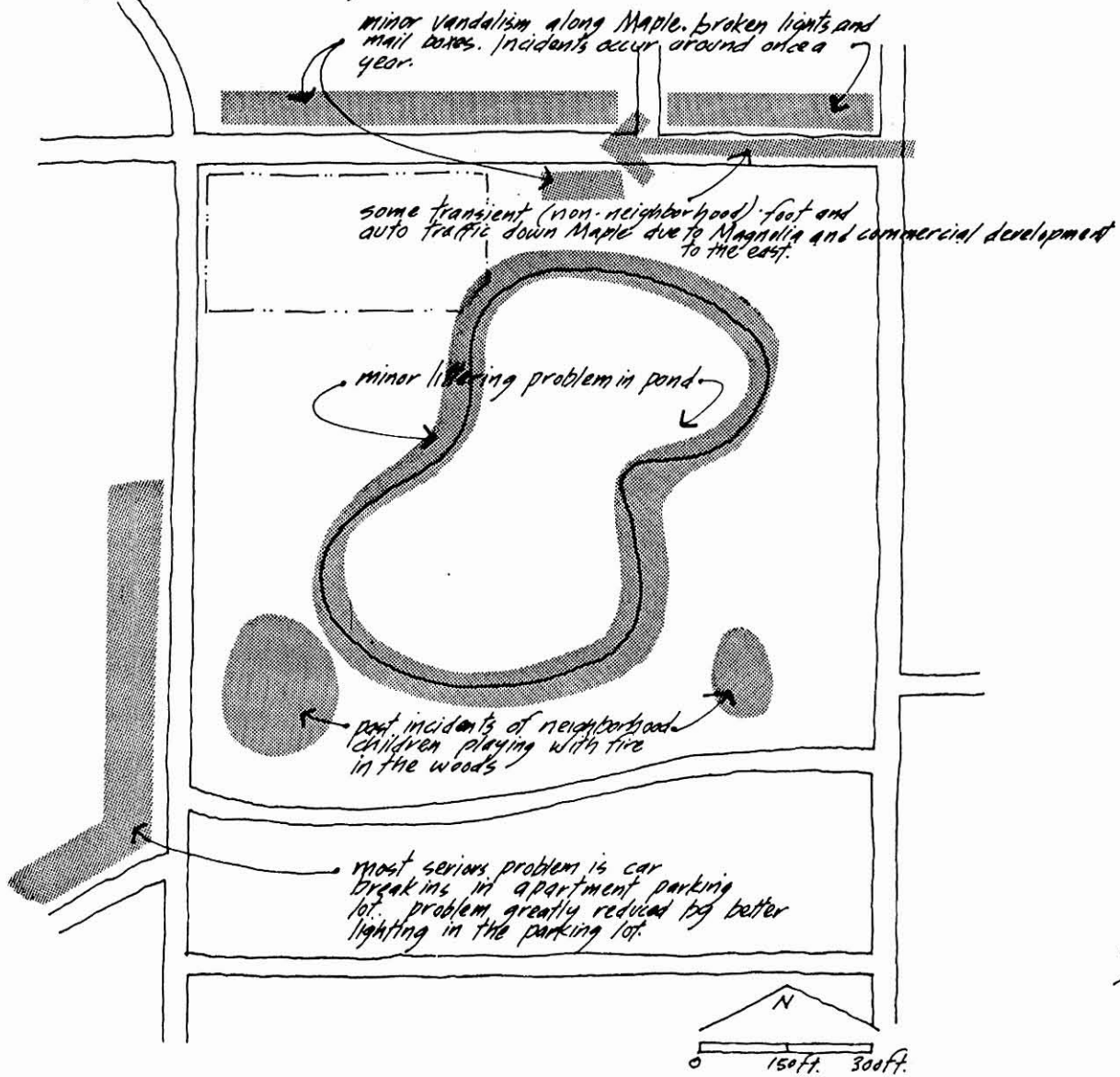

# ● Attitudes about the project and neighborhood

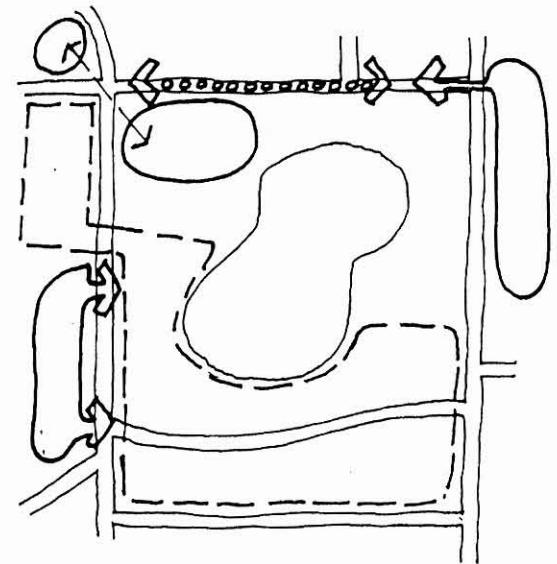
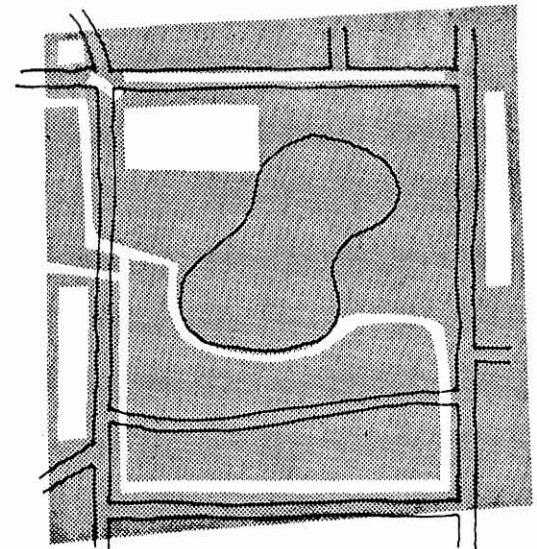
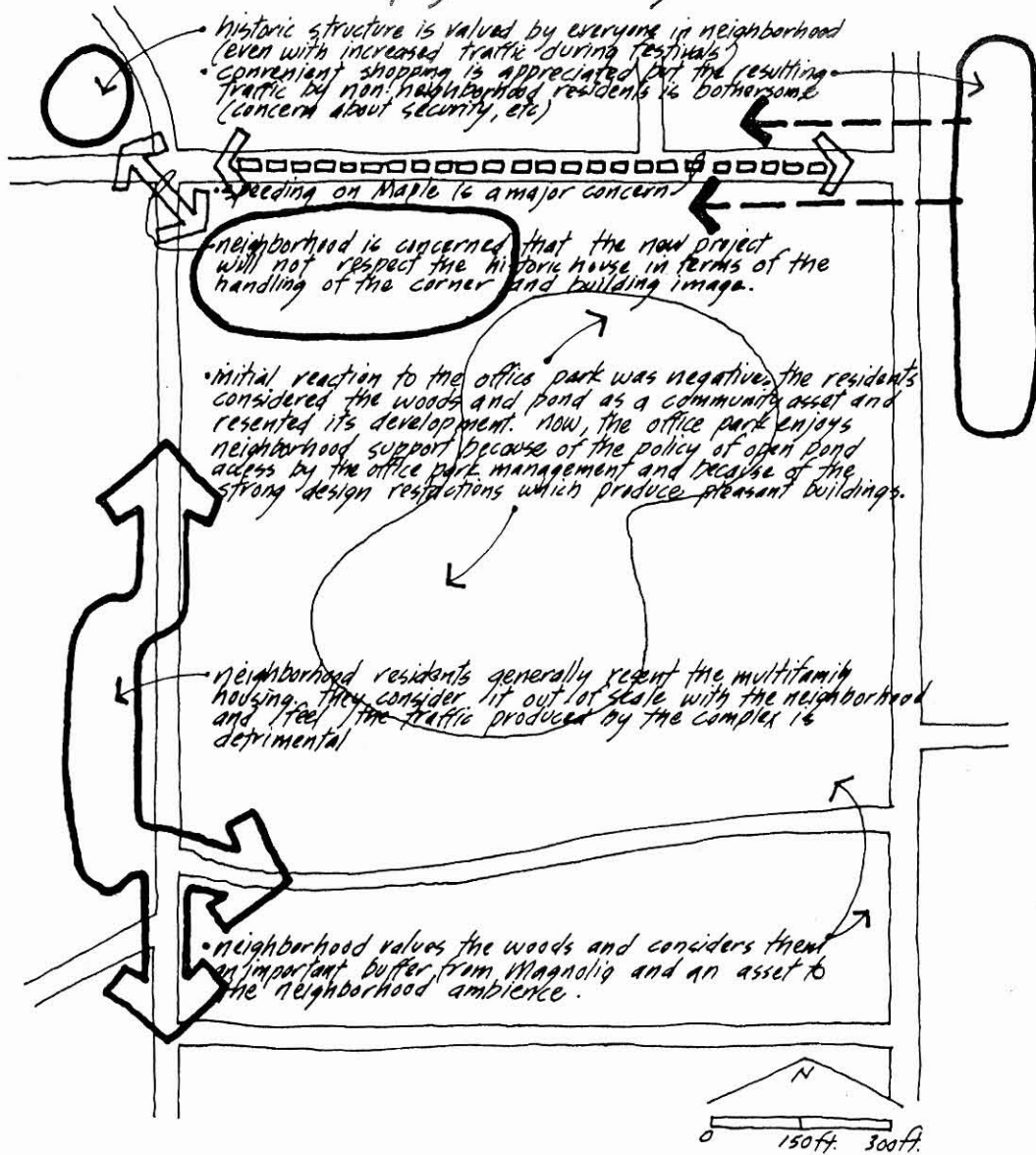

# Climate

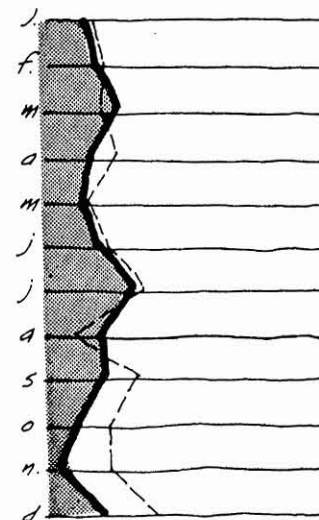
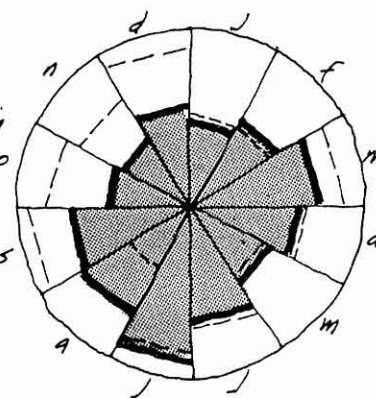
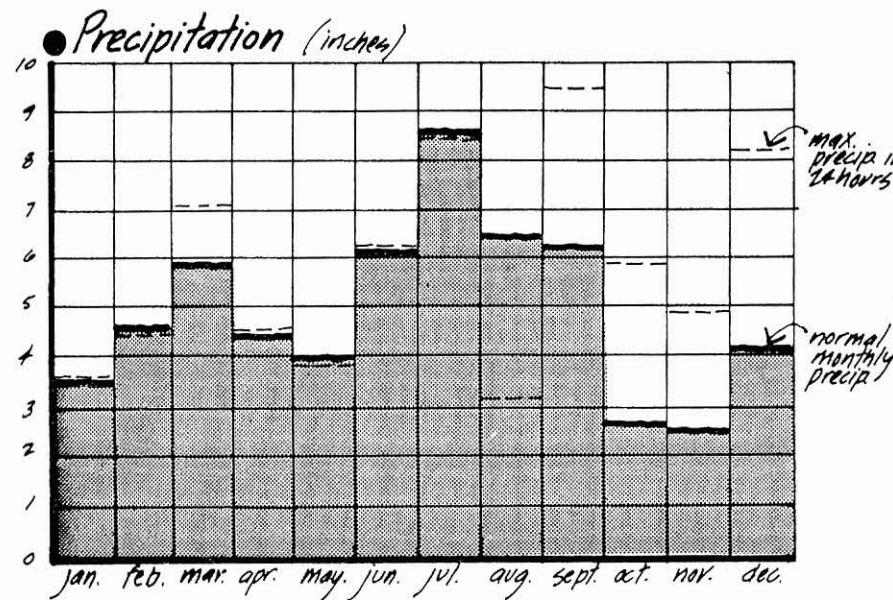
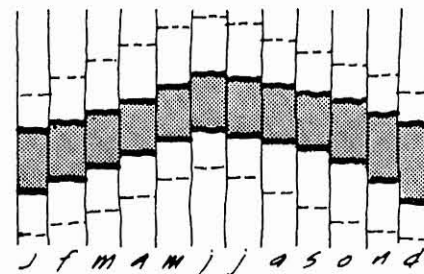
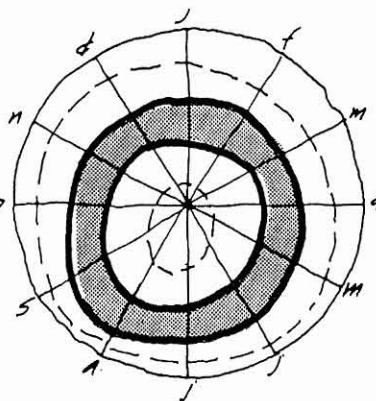
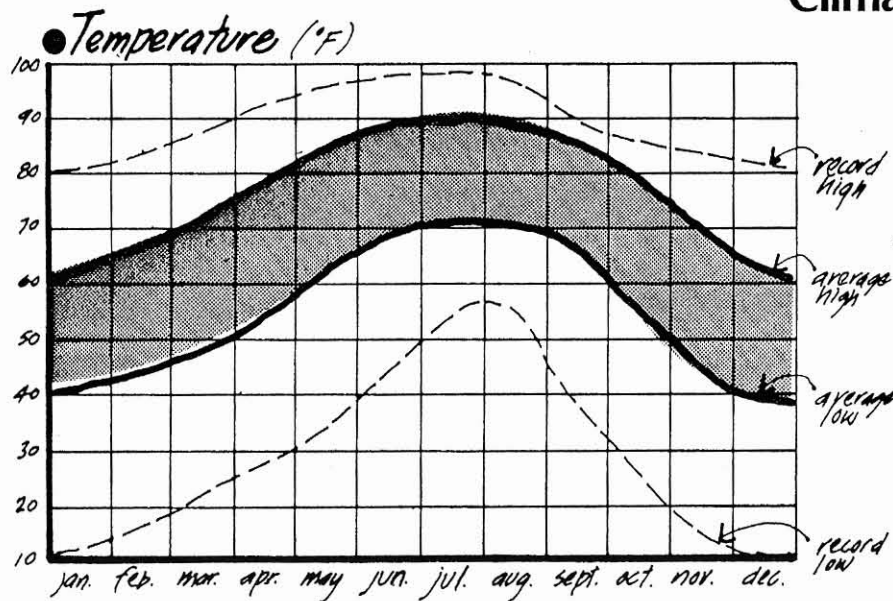

# Relative humidity (%)

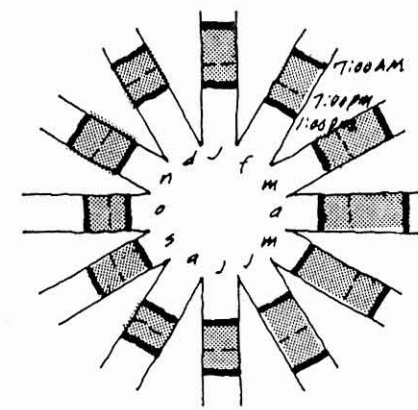
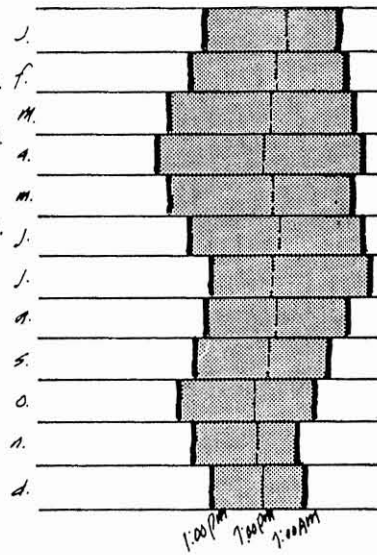
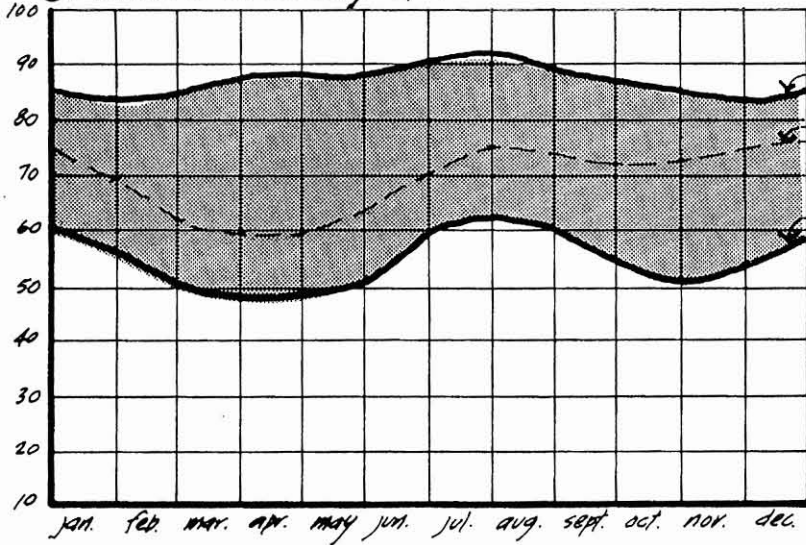

# Wind (ave. MPH)

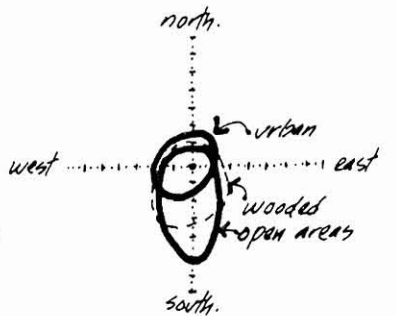
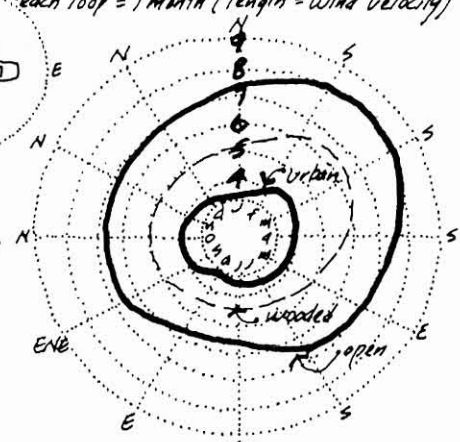
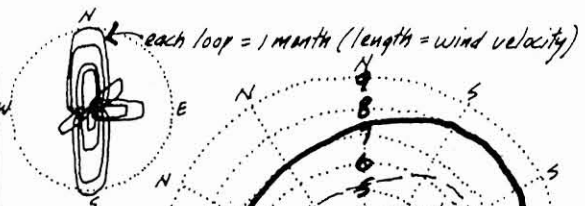
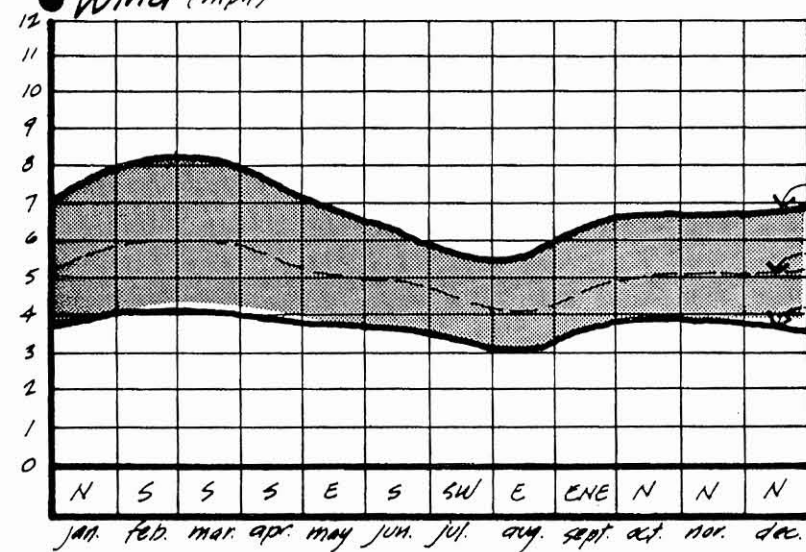

Wind rose for March showing velocity and prevailing direction. Wind roses can be drawn for each month.

prevailing direction

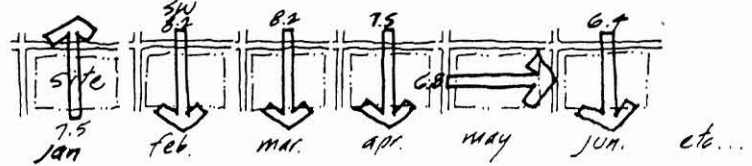

### ● Sky cover (days)

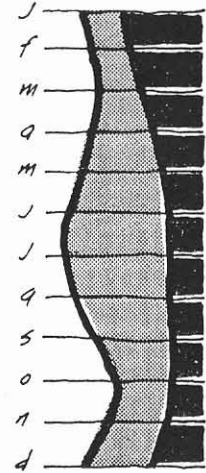
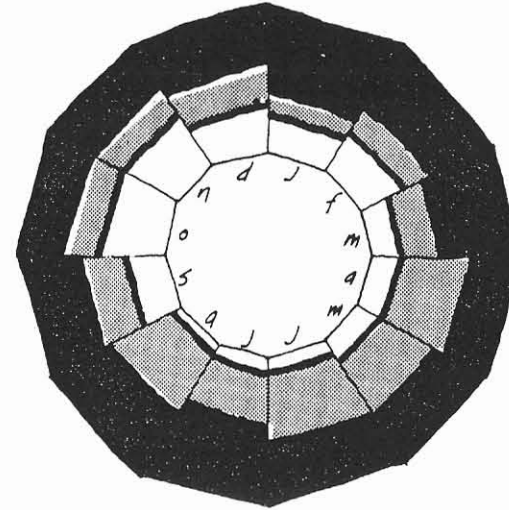
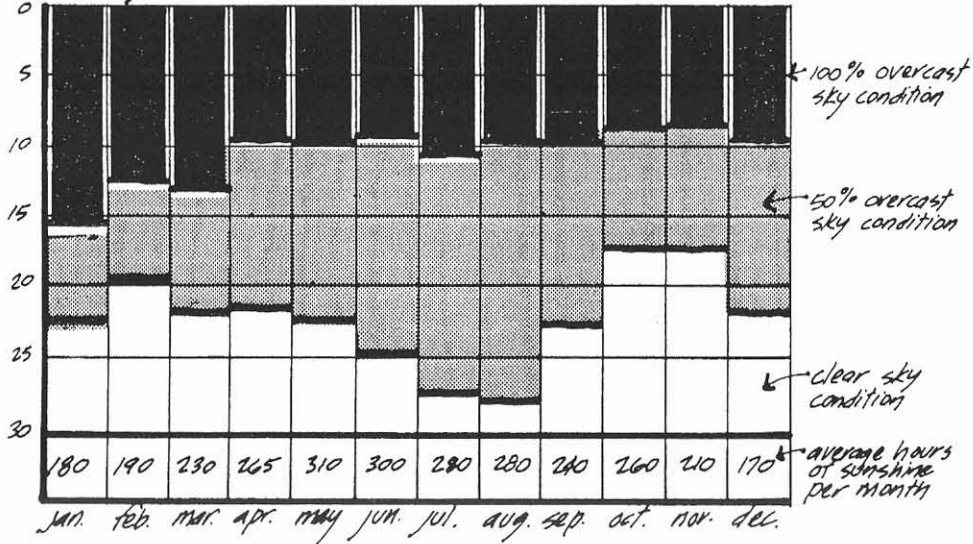

### ● Normal degree days (°F/day) ave. yearly cooling degree days - 2596 ave. yearly heating degree days - 1327

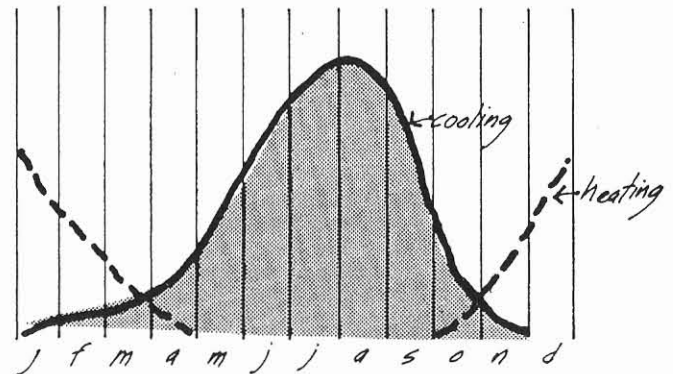
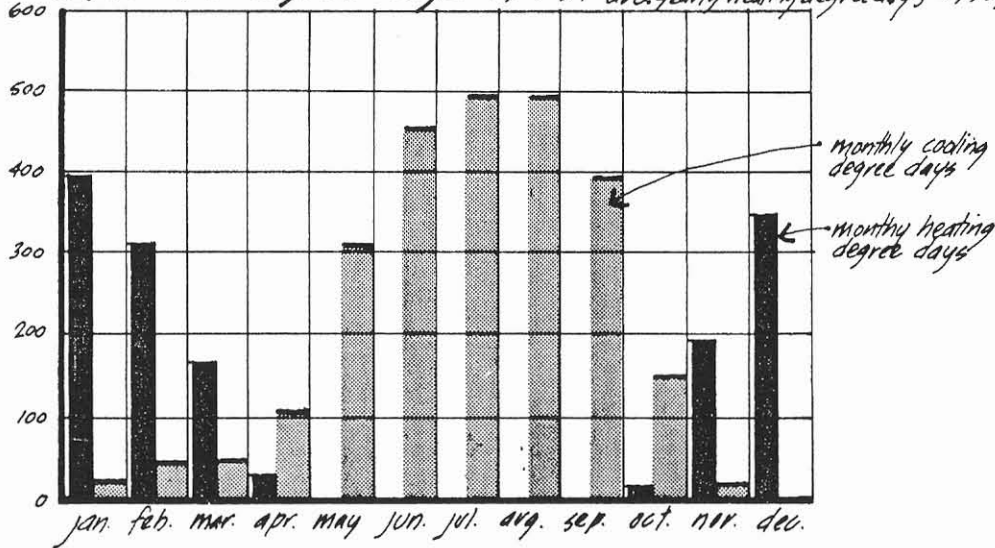

# Solar altitude and azimuth (degrees)

	W	W	W	W	W	W	W	W	W	W	W	W	W	W	W	W	W	W	W	W	W	W		
5																								
6	72	80	89	6	100	10	108	11	110	10	108	6	100											
7	2	65	7	72	12	82	18	87	22	101	24	101	22	101	18	87	13	82	6	72	2	65		
8	13	57	19	64	25	73	31	85	35	95	36	98	35	95	32	85	25	73	18	63	13	56	11	54
9	23	46	30	53	37	63	44	75	48	87	49	88	48	87	44	76	37	63	29	52	23	46	21	44
10	32	33	39	39	48	48	56	62	61	76	62	83	61	77	56	62	48	48	39	39	31	33	29	31
11	37	18	46	21	56	27	66	40	73	56	75	66	73	57	66	40	56	28	45	21	37	17	34	17
noon	39	0	48	0	59	0	71	0	80	0	83	0	80	0	71	0	59	0	48	0	39	0	36	0
	E	E	E	E	E	E	E	E	E	E	E	E	E	E	E	E	E	E	E	E	E	E	E	E
	jan	feb.	mar.	apr.	may	jun.	jul.	aug.	sep.	oct.	nov.	dec.												

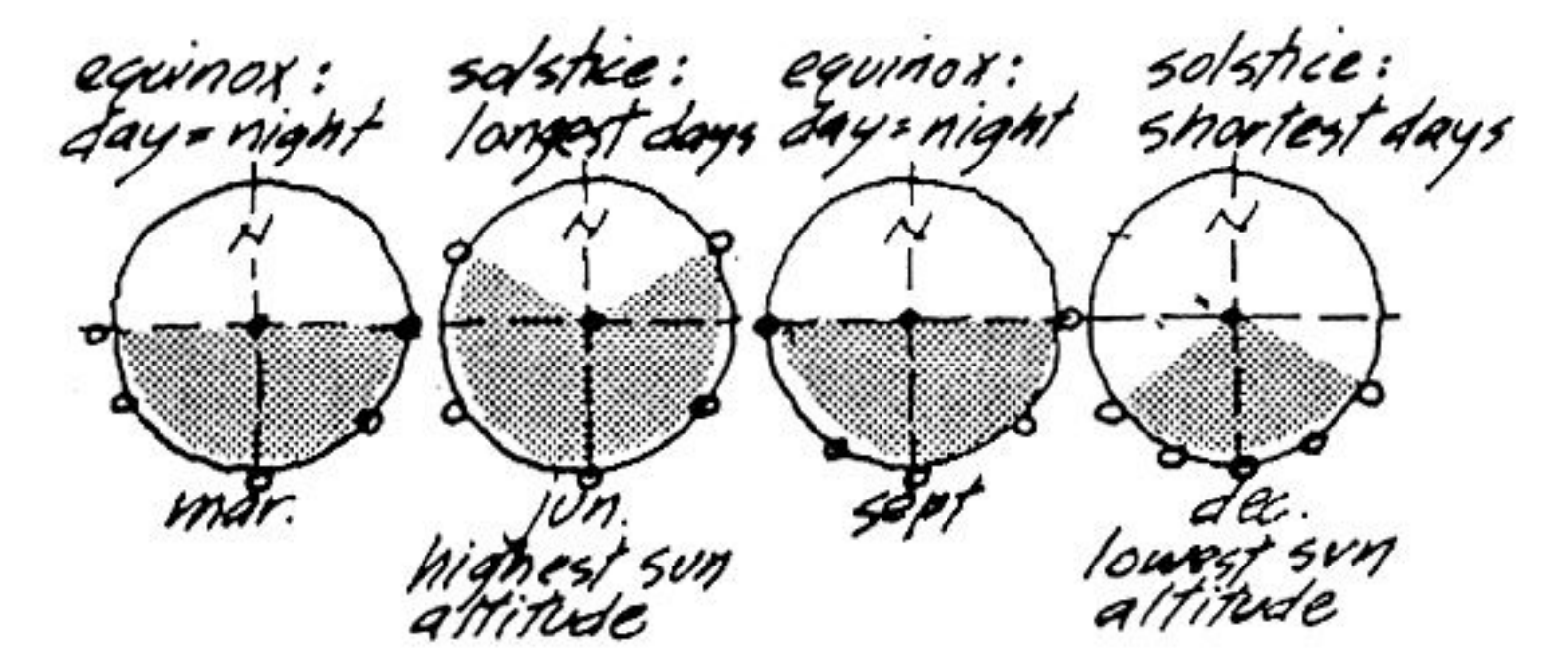
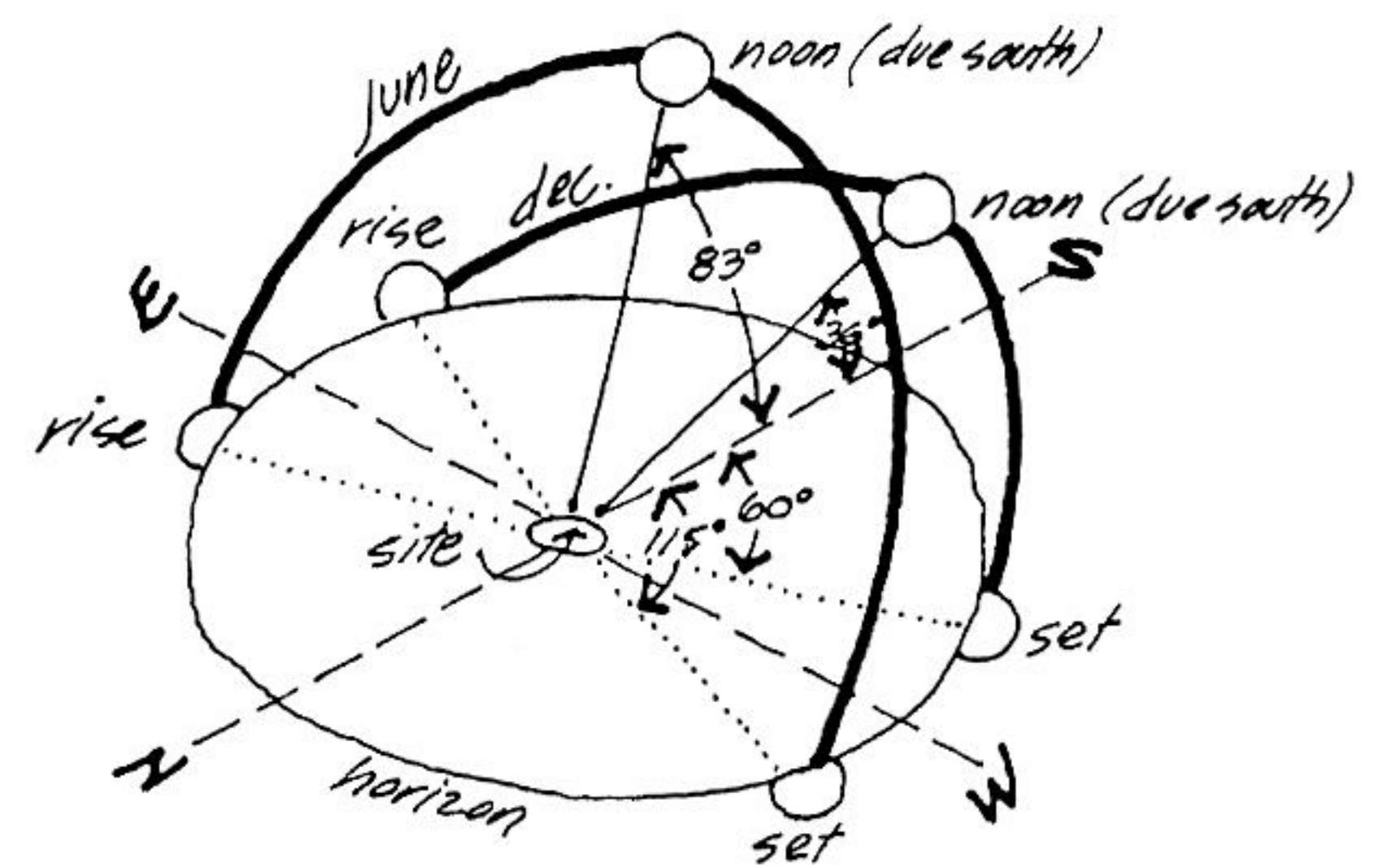
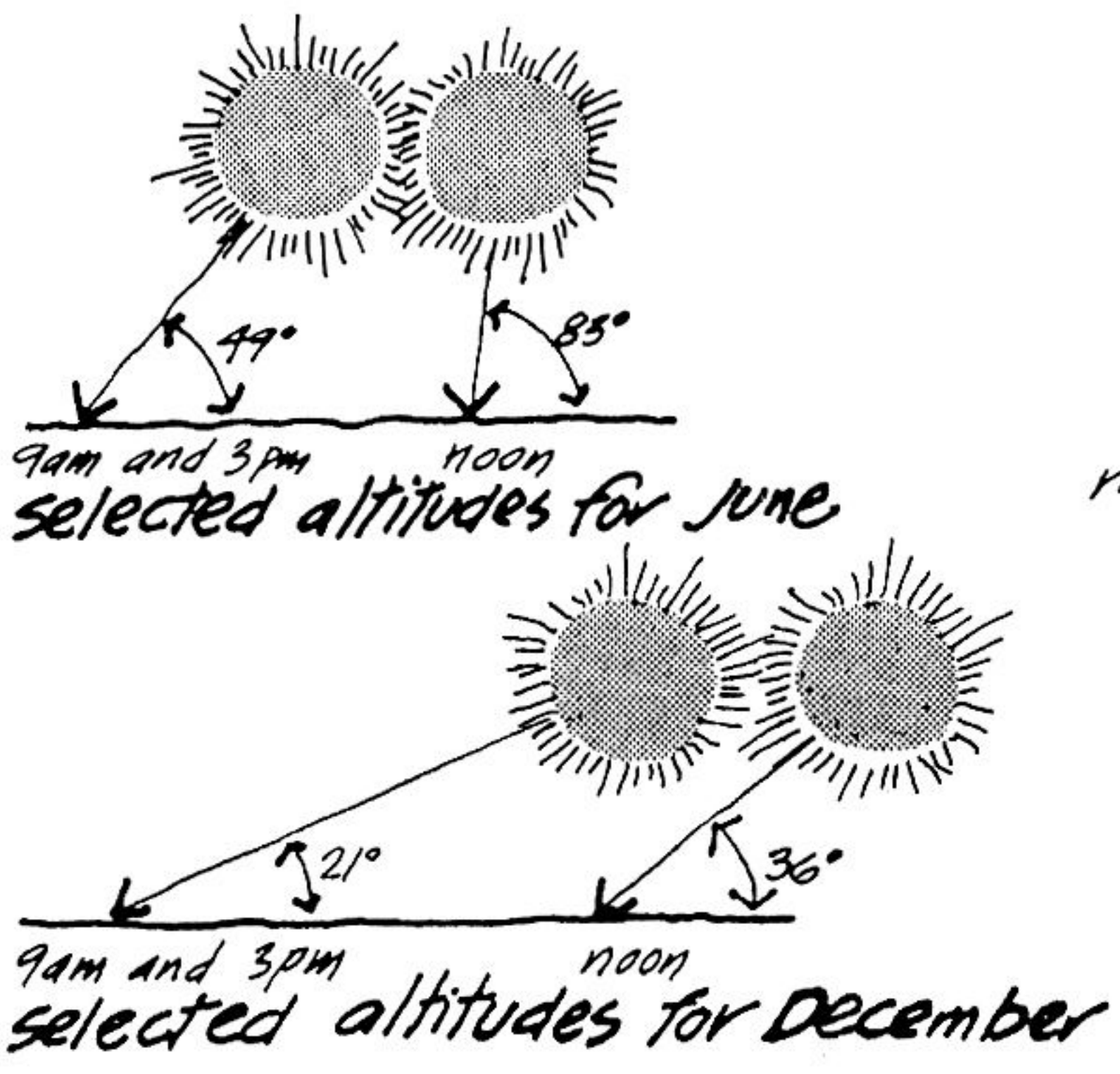
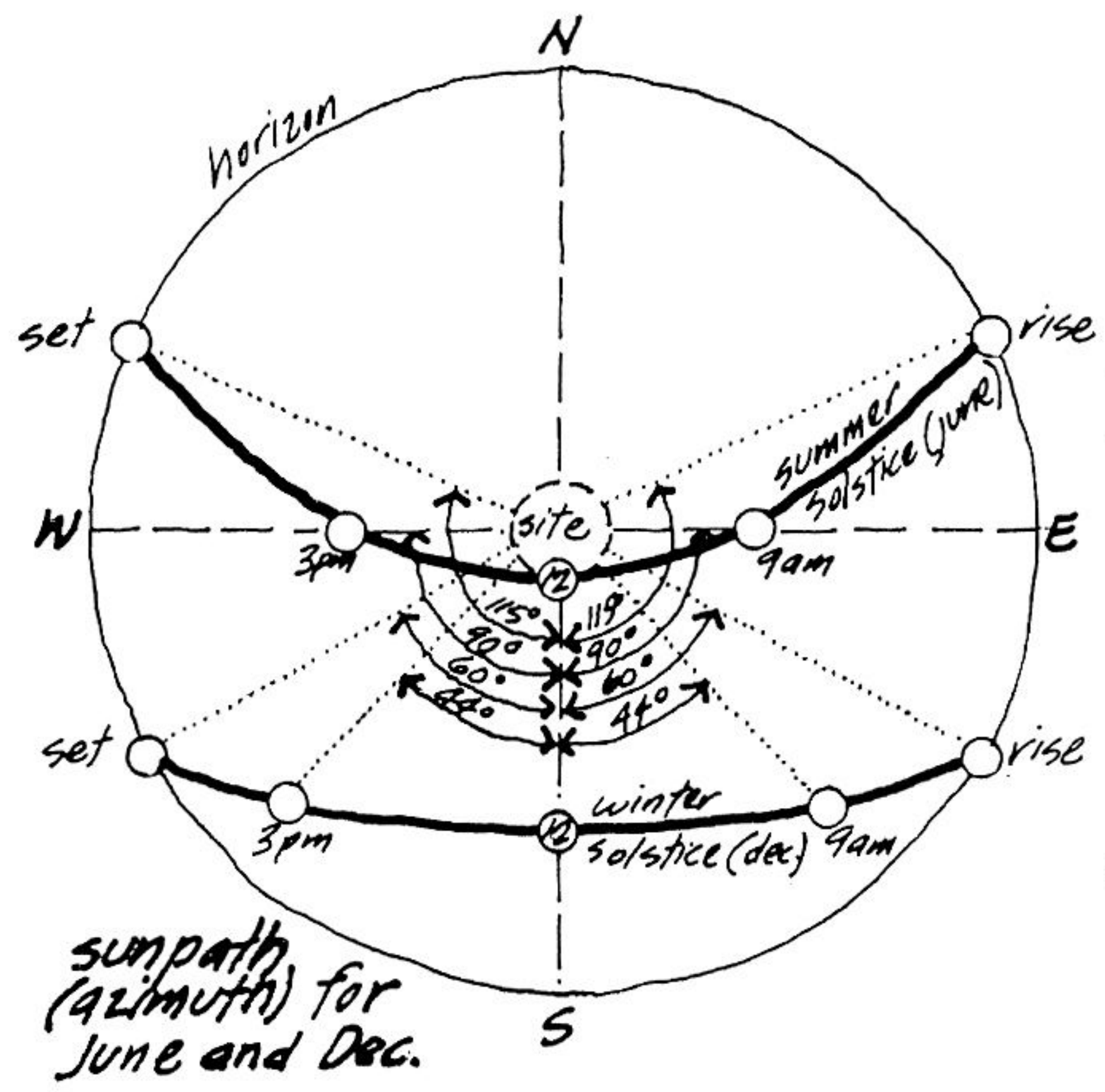
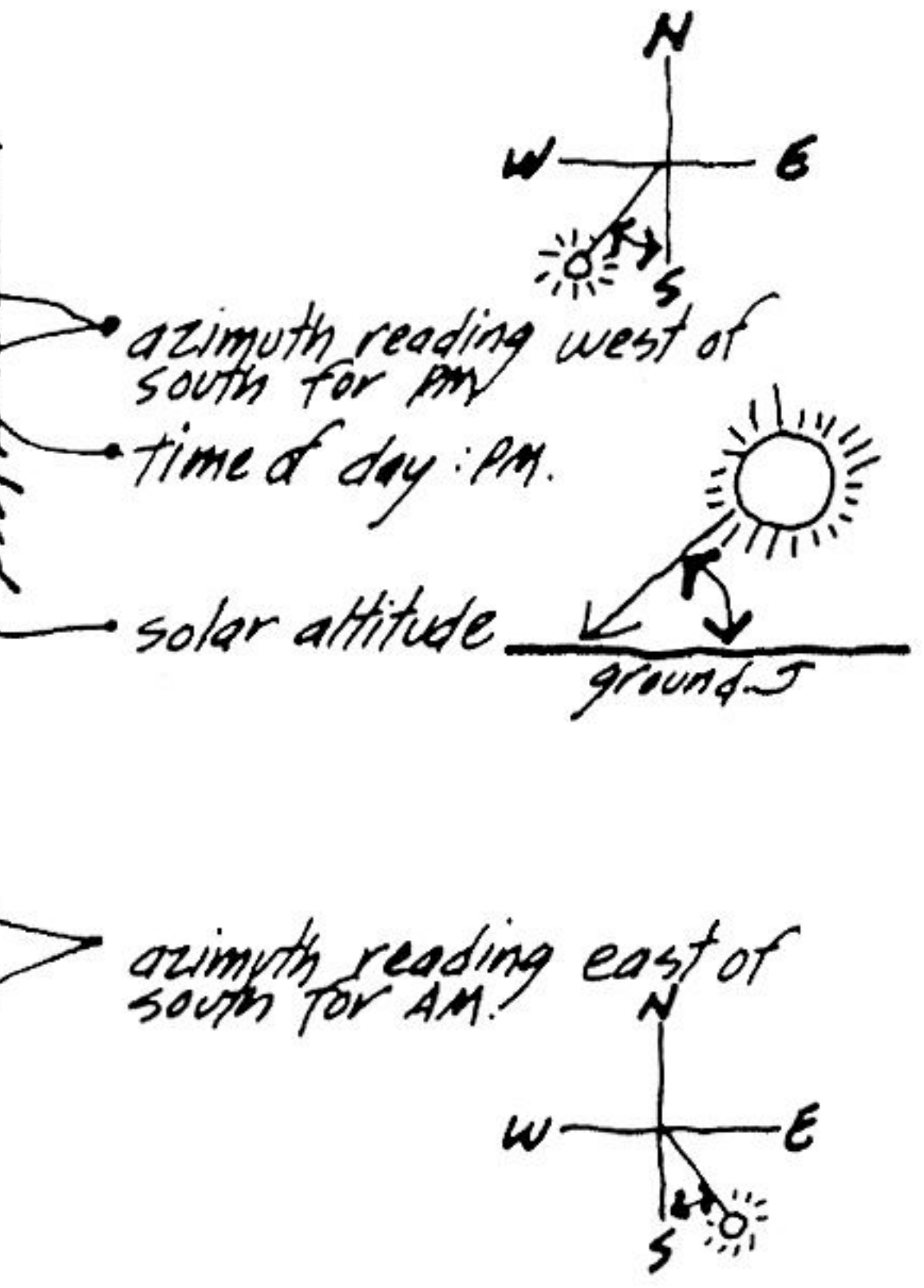

# Weather relationships

charts

MONTH	Temperature °			rain (inches)	humidity%		Wind (open areas)		sky cover (days)			degree days	
	high	low	ave.		AMT	PM	dir.	speed (mph)	100% cloudy	50% cloudy	clear	heat	cool
J	65	40	52	3.5	84	58	N	7.5	15	8	8	400	25
F	68	44	56	4.5	83	54	S	8.2	12	6	10	315	40
M	75	47	62	5.8	86	49	S	8.2	13	9	9	160	45
A	82	50	65	4.3	88	48	S	7.5	9	13	8	30	100
M	87	58	75	4	87	50	E	6.8	10	13	8	0	300
J	90	66	78	6.2	90	55	S	6.4	9	16	5	0	450
J	92	70	80	8.6	92	62	SW	5.6	11	10	4	0	480
A	90	68	80	6.4	90	62	E	5.8	10	18	3	0	500
S	88	60	75	6.2	87	57	ENE	6.4	10	13	7	0	380
O	83	50	67	2.7	86	53	N	6.7	8	9	14	20	160
N	75	40	58	2.6	85	53	N	6.7	7	10	13	200	15
D	65	38	50	4.1	84	57	N	6.8	9	13	9	350	0

juxtaposed graphs

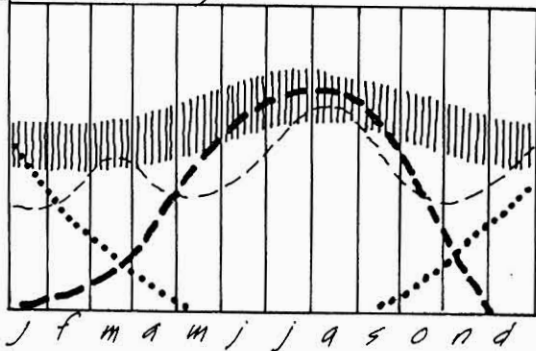

transparent overlays

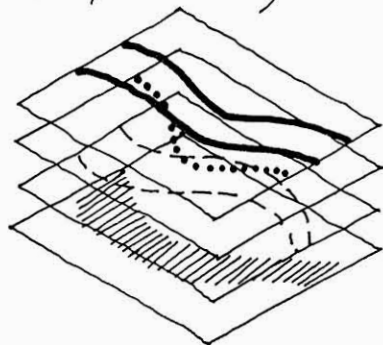

stacked graphs

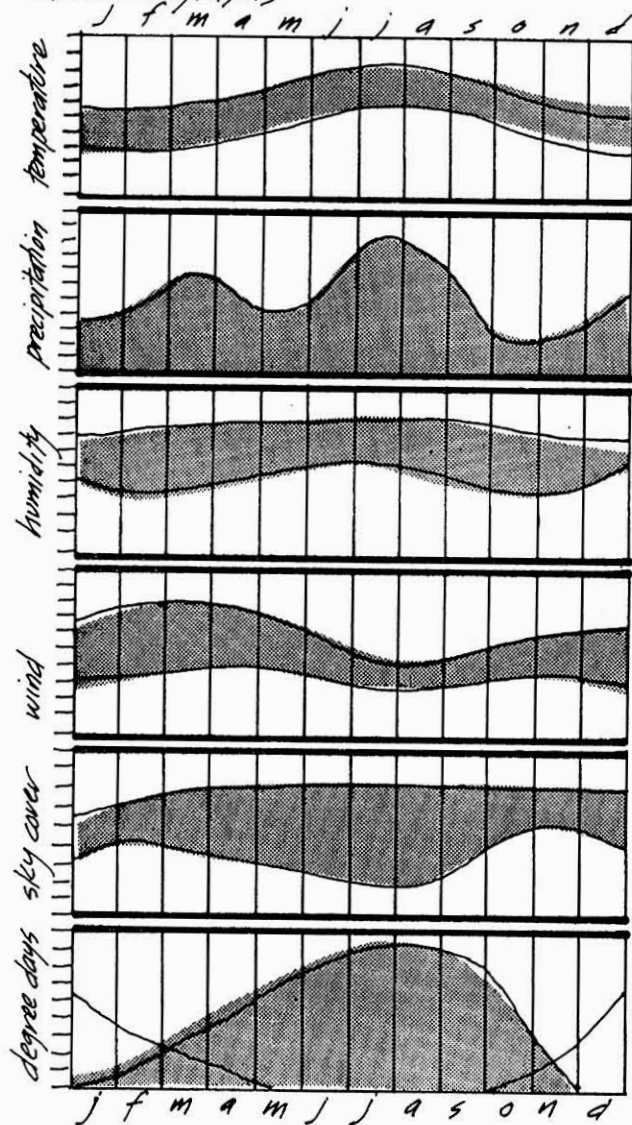



## REFINEMENT AND SIMPLIFICATION

If we are collecting and diagramming the site information for ourselves, we will probably spend very little time refining our initial sketches made at the site over the referent drawings. If the diagrams are to be viewed by others we may spend some time fine tuning our graphics.

When first learning to diagram it is a good idea to refine and simplify all of our work until we develop an ability to diagram with effective, simplified forms in making our initial fact collection sketches.

**Refinement involves making the diagrammatic forms as communicative as possible while simplification is concerned with the process of subtracting any extraneous graphic information from the diagrams.**

Diagrammatic refinement should thoroughly evaluate each visual characteristic of each graphic element in the diagram to determine if it can be improved.

**Improvement is essentially toward strengthening the meaning transfer between what the diagram is saying visually and what the site fact is saying contextually.**

Refinement can also involve the streamlining of the graphics simply for the sake of better graphics.

In this case we attempt to elevate the quality of the graphic images to upgrade the visual competence of the presentation.

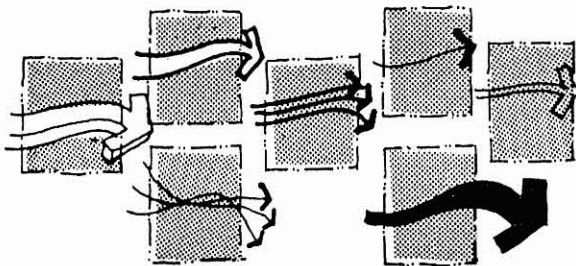
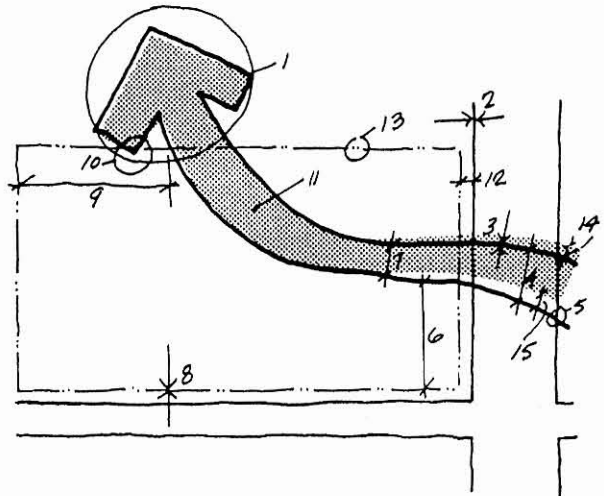
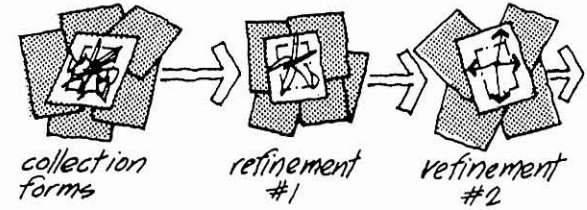

Typical aspects of diagrams that may be targets for refinement are presented on the following pages.



● Accuracy of the forms in terms of placement over the referent drawings

initial diagram

refined diagram

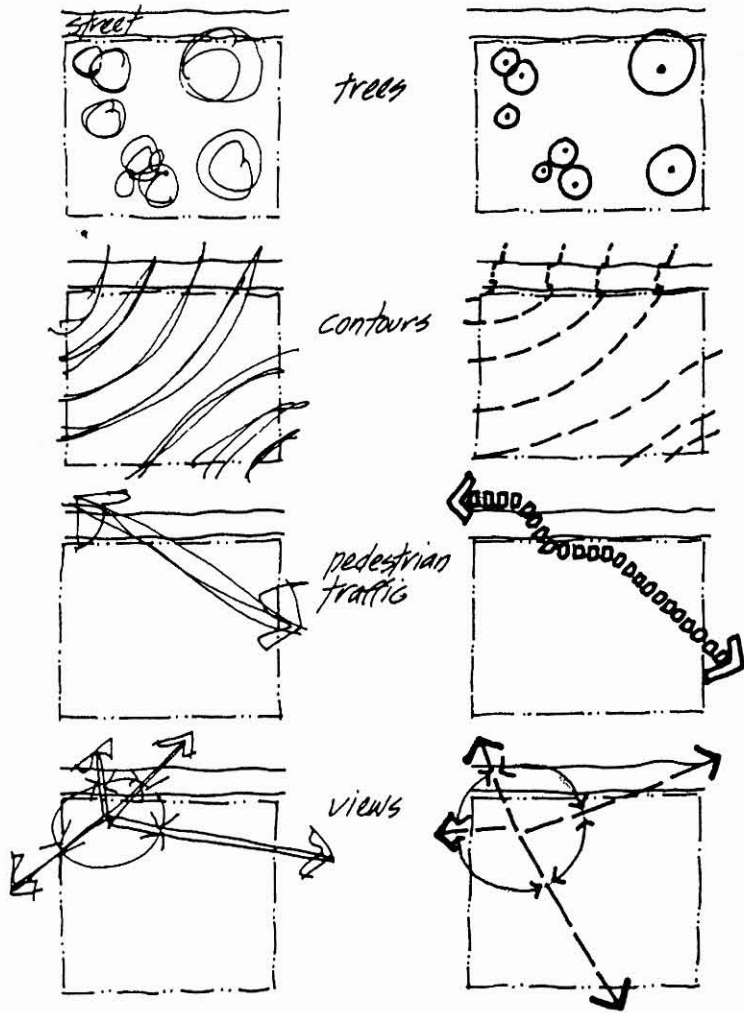

● Diagrammatic shapes

initial diagram

refined diagram

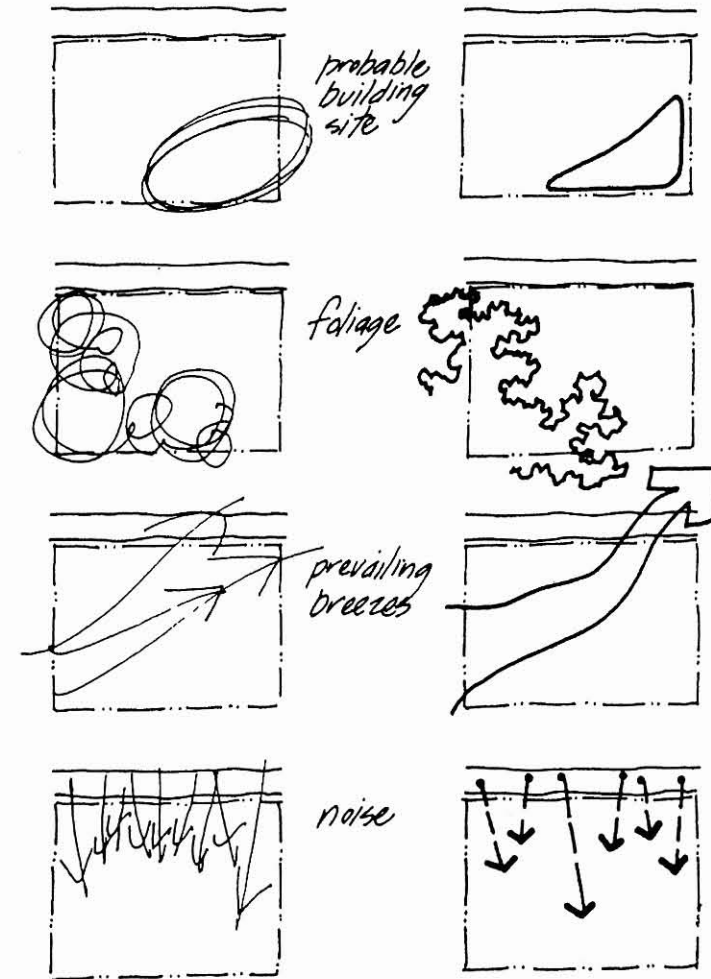

● Paths of linework

initial diagram

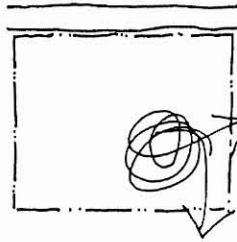

children's play patterns

refined diagram

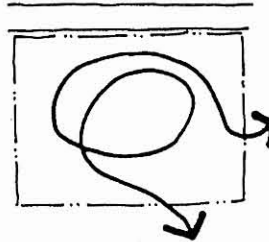

drainage artery

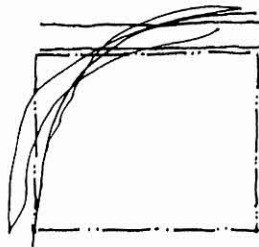
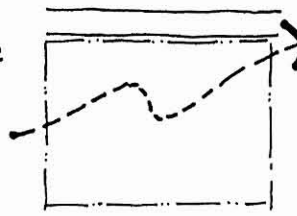

bicycle circulation

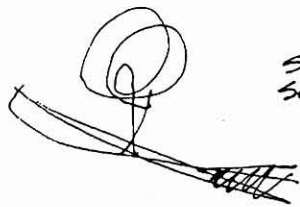
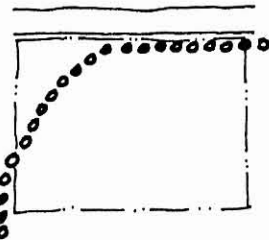

site section

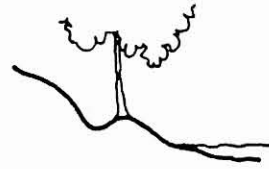

● Quality of linework

initial diagram

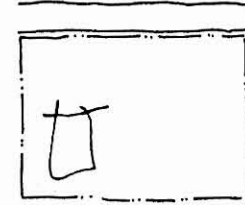

on site structure

refined diagram

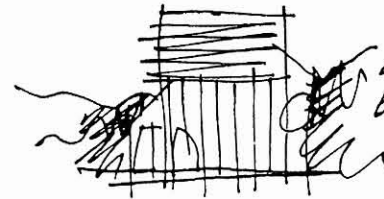
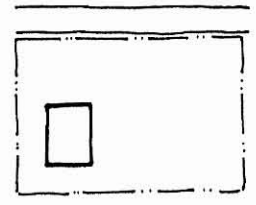

adjacent building

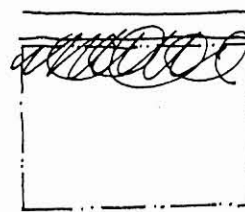
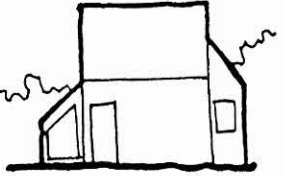

tree lined street

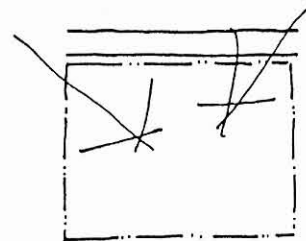
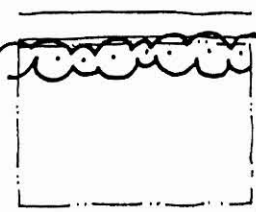

major views into the site

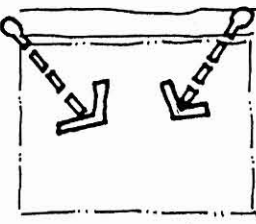

● *Line thickness*

*initial diagram*

*refined diagram*

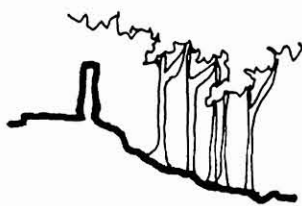
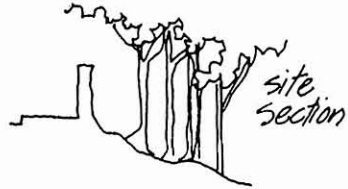
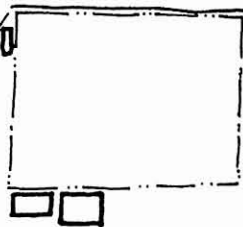
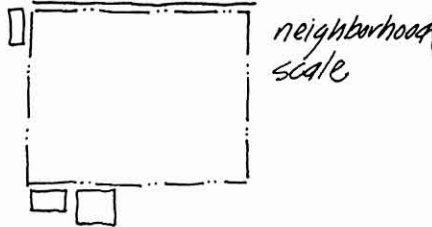
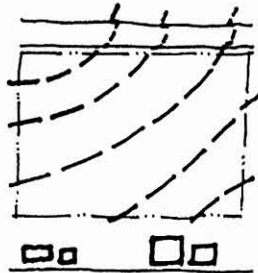
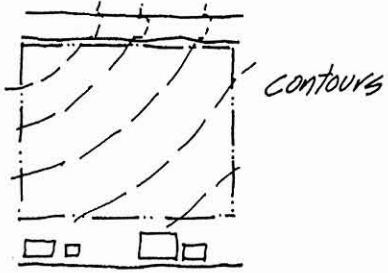
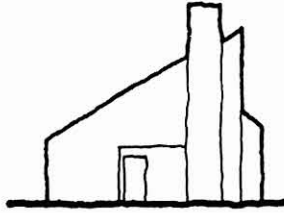

● *Variation in line thickness*

*initial diagram*

*refined diagram*

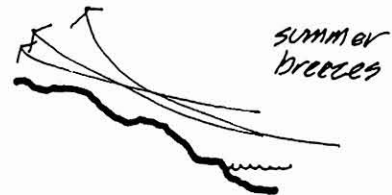
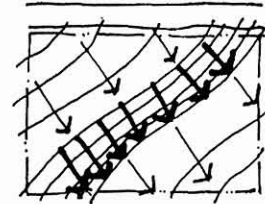
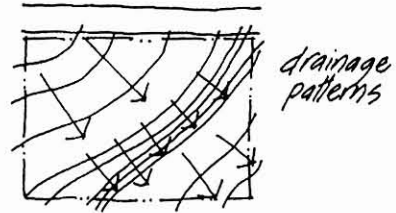
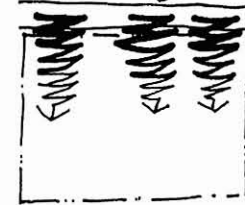
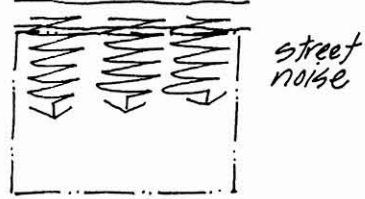
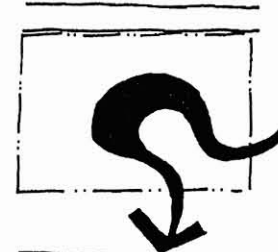
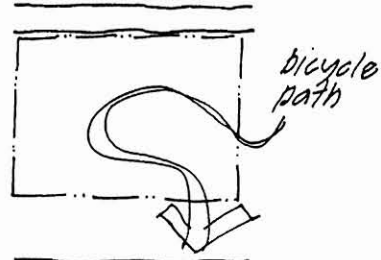

● Choice of tone or color

initial diagram

refined diagram

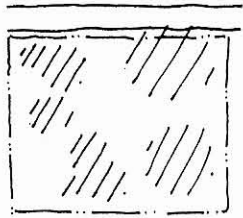

trees

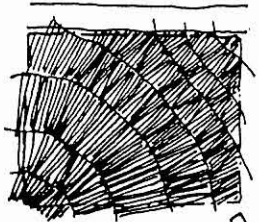
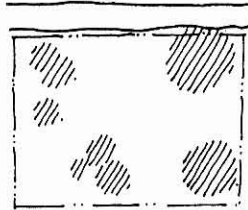

contours

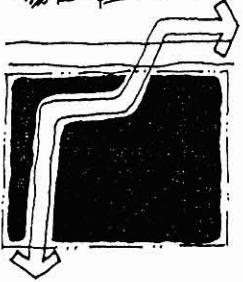
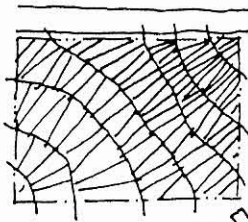

drainage easement

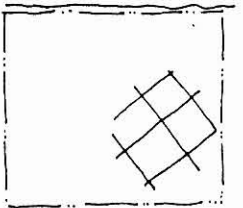
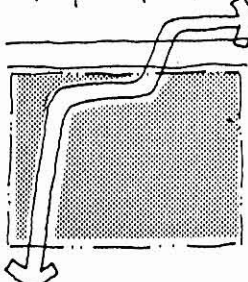

poor soil bearing condition

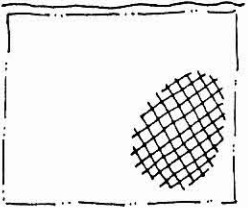

● Number of tones or colors

initial diagram

refined diagram

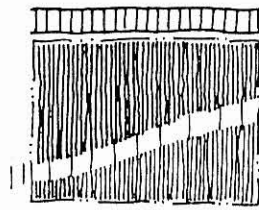

on site creek

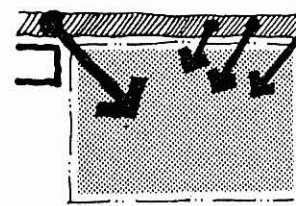
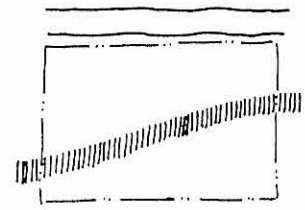

view to site from road

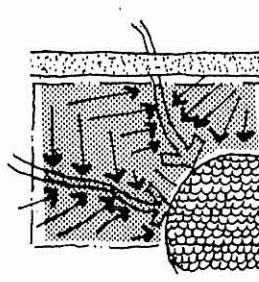
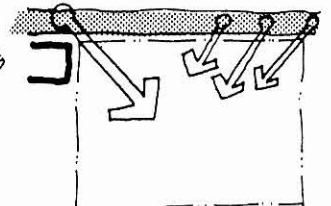

drainage to pond

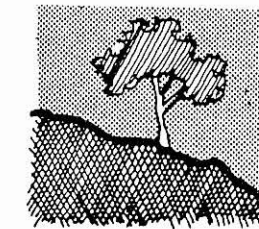
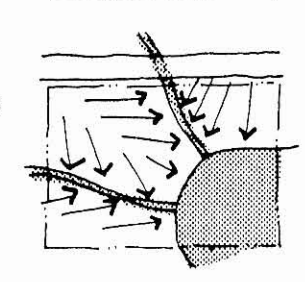

site section

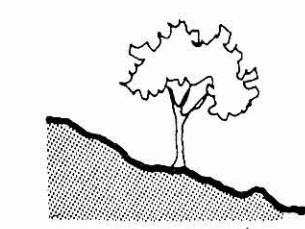

● Diagram size

initial diagram

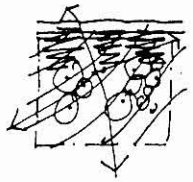

composite diagram

refined diagram

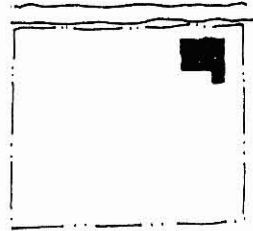
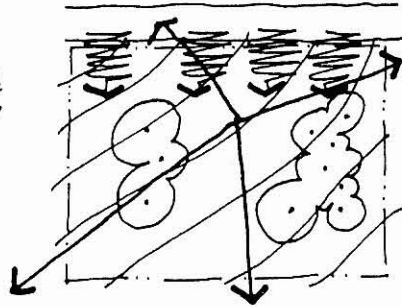

on site structure

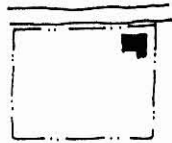

historic structure



street elevation across from site

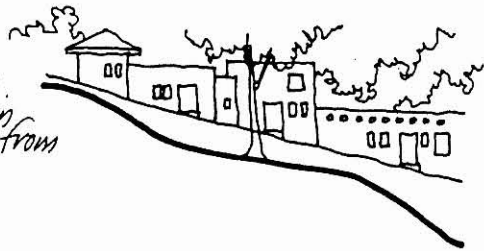

● Placement of tone or color

initial diagram

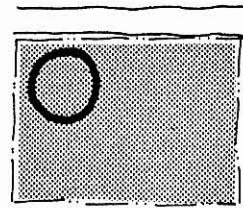

preferable building site

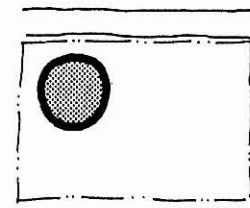

refined diagram

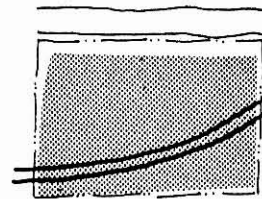

path through sites

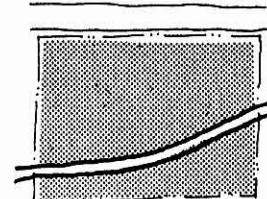

street elevation

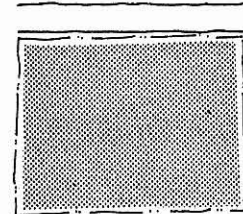
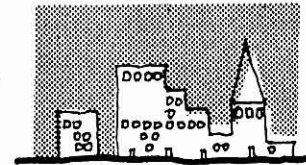

street traffic

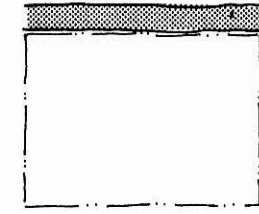

● *Relation between diagrams*



● *Relation between diagram and referent drawing*

*initial diagram*

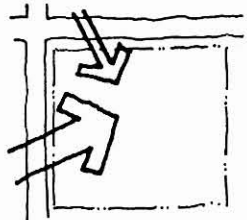

*vehicular access*

*refined diagram*

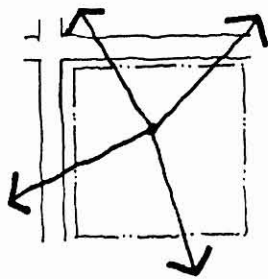
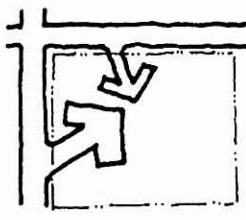

*views from the site*

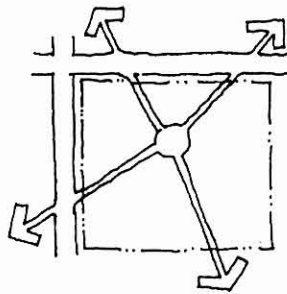

● *Relation between diagram and border*

*initial diagram*

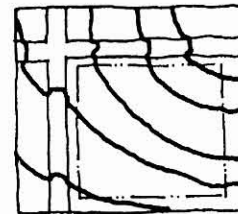

*contours*

*refined diagram*

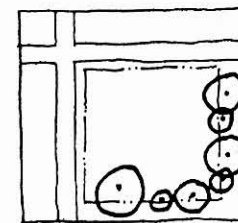
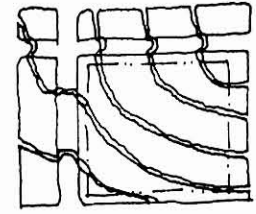

*major trees*

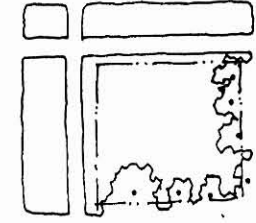

● *Relation of tone to line*

*initial diagram*

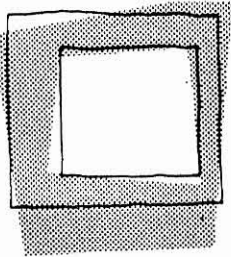
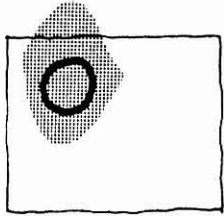
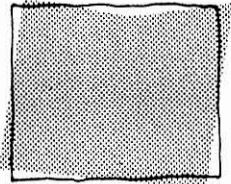
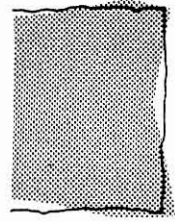

*refined diagram*

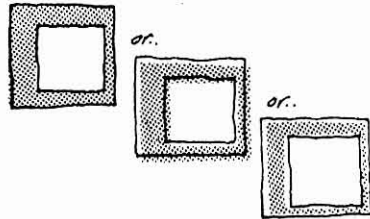
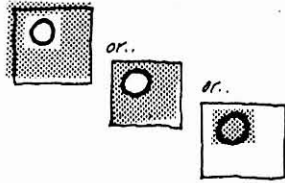
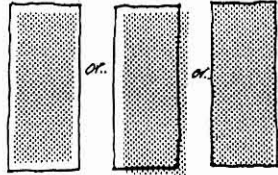
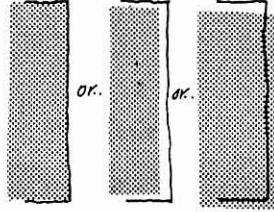

● *Arrowheads*

*initial diagrams*

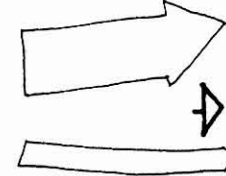
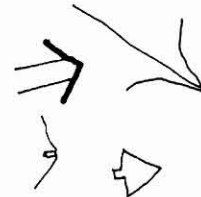
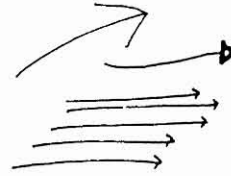

*refined diagrams*

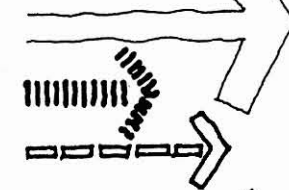
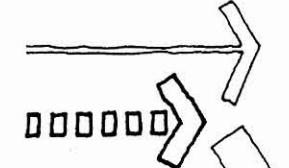
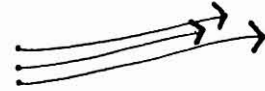
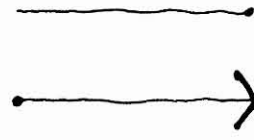

Simplification deals with the same aspects just listed and is an integral component of refinement.

When simplifying a diagram we are interested in subtracting any elements, shapes, wrinkles or relationships that muddle the meaning transfer between

the diagram and the site fact. These extraneous graphics do not contribute to the communication of the site fact and often convey inadvertent messages that are misleading. They cloud over the essence of the message by producing visual noise.

Our goal in simplification is to reduce the diagram to the minimum graphic information that still communicates the message. This reduction helps to ensure that we have a diagram that is more likely to communicate the desired information and less likely to be misinterpreted. Some examples of diagram simplification are presented on the next page.

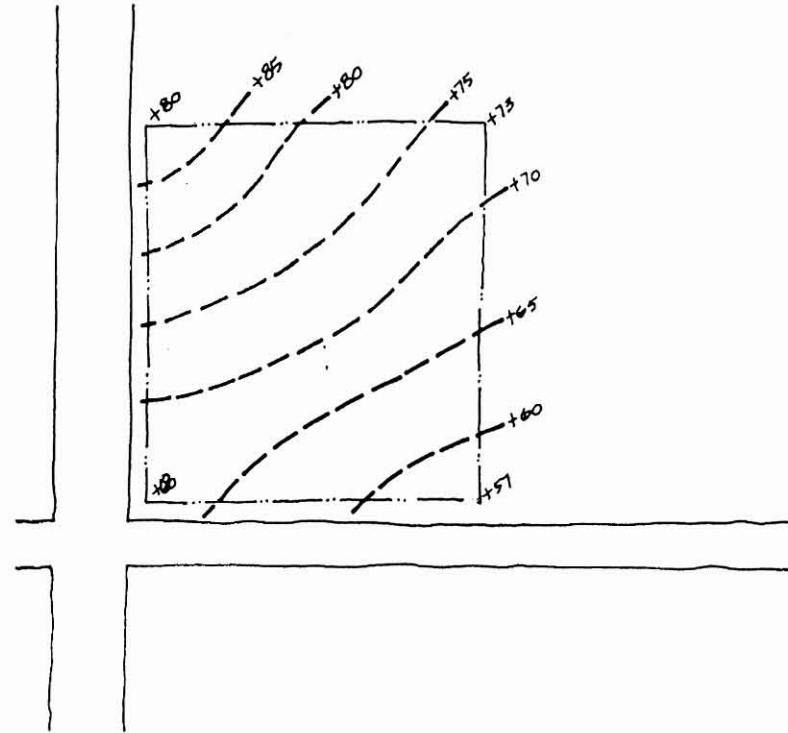
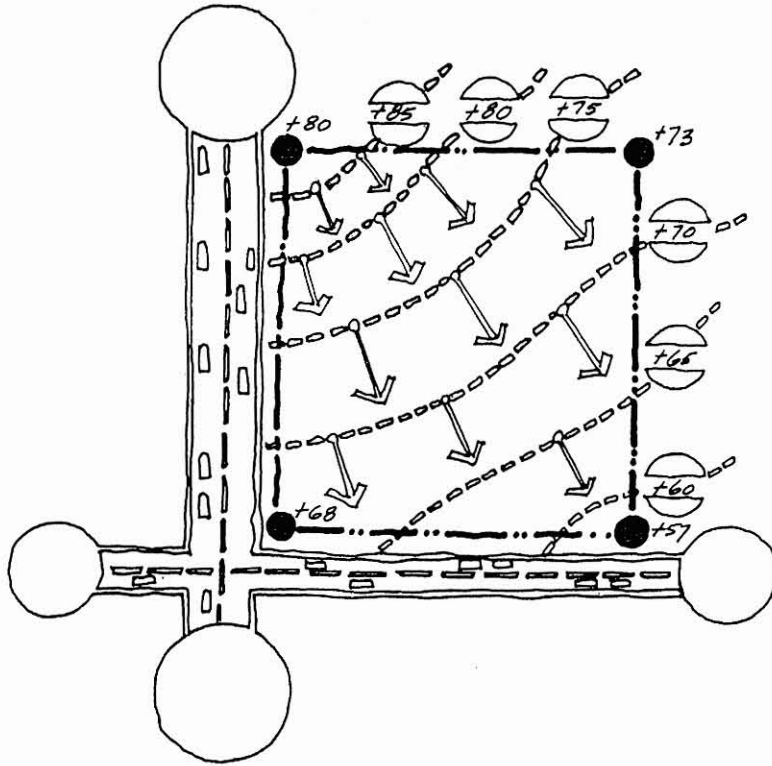



# ● Examples of diagram simplification

initial diagram

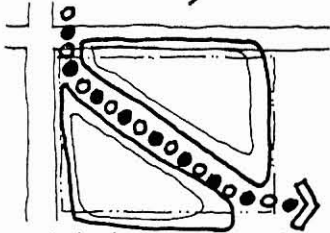

pedestrian traffic through the site

simplified diagram

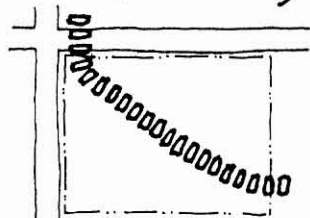

initial diagram

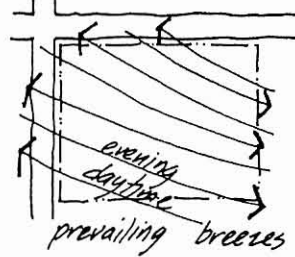

prevailing breezes

simplified diagram

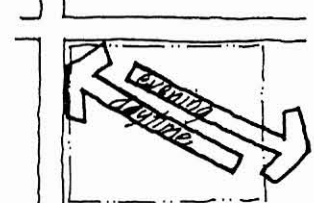

existing trees on the site

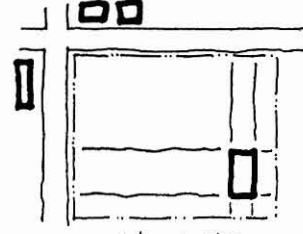
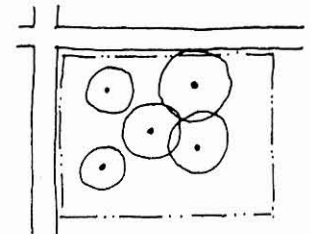

on site buildings

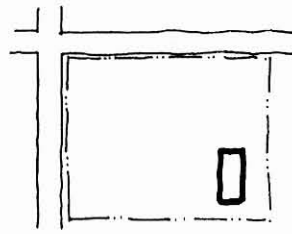

site section

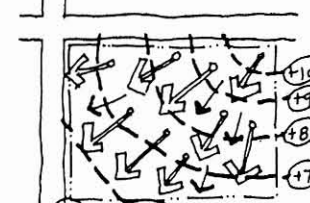
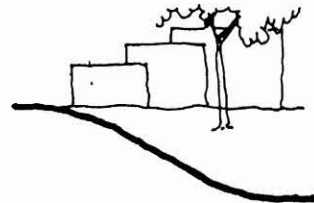

contours and drainage

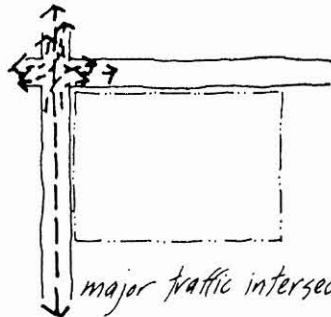
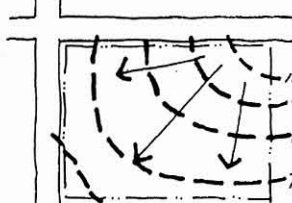

major traffic intersection

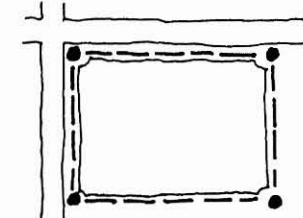
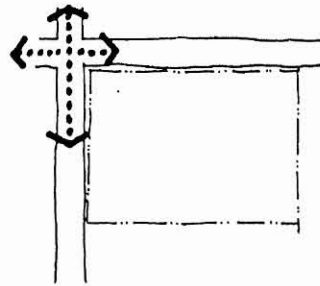

boundaries

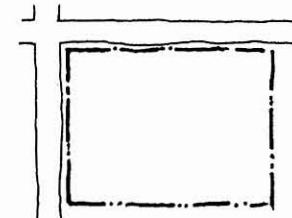

## GRAPHIC EMPHASIS AND CLARITY

Having refined and simplified our diagrams so that their graphic forms reinforce and are congruent with the content we are expressing, we are ready to clarify our diagrams through graphic emphasis.

**Simply put, graphic emphasis involves making sure that the essence of what we are communicating with the diagram receives the strongest expression graphically.**

In contextual analysis, this means that we want the referent drawing to recede into the background graphically and whatever we have diagrammed over the referent (the site issue) to be the boldest visual aspect in the diagram. Normally this is accomplished through lineweight and tone or color.

The referent drawing is usually made with a thin line and no tonework. The site fact diagrammed over the referent is then done with a thicker lineweight or with tone or color.

**It is helpful when reading a series of contextual diagrams if there is a sense of system or pattern in the way the graphic emphasis has been achieved.**

Once we realize that the essence of a site fact or issue is always expressed in tone for each diagram, we can more efficiently understand the entire analysis. If we have chosen to use color, we should use the same color to code the essence of all our diagrams. That color should remain the

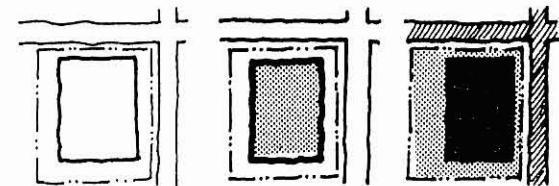
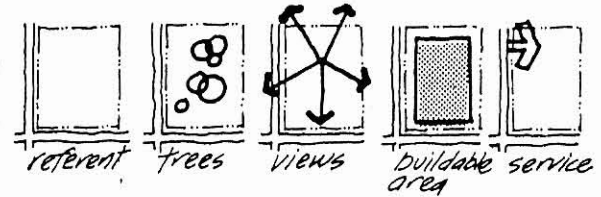
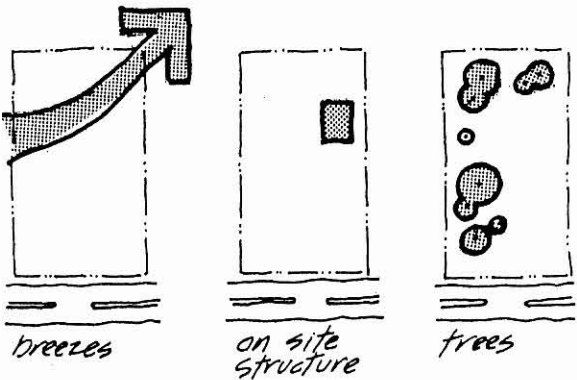
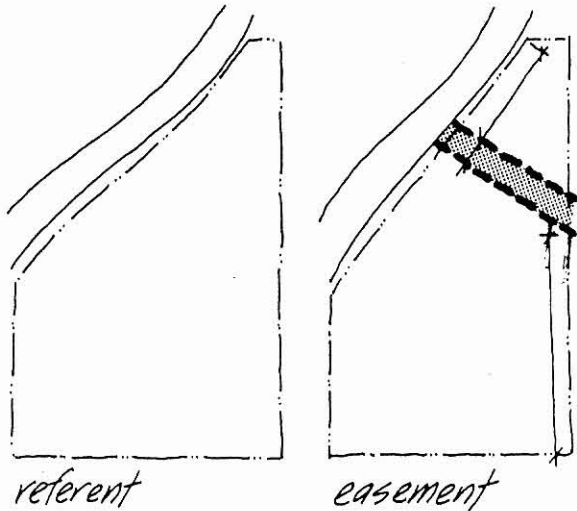

boldest aspect of the diagrams. We may escalate the boldness of our diagrams as much as we want as long as the relative strength of the essence of the diagrams dominates the graphics.

If we have begun to use a particular color to code the key points of our diagrams we should not create confusion by shifting the use of the color around from meaning to meaning.

The essence of pattern is consistency and once we have educated the eye to look for a color or tone to signal the essence of the diagram's meaning, it becomes extremely confusing and annoying to have that pattern change arbitrarily.



It is of value to graphically code the site factors which we feel are of particular importance or which may have significant form giving implications in design. This may be done with dots, frames around important diagrams or other graphic means.

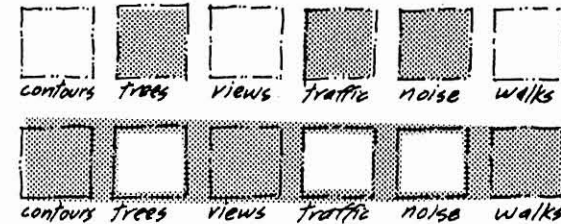

### TITLES, LABELS AND NOTES

Because we are attempting to graphically communicate the contextual issues, we should keep our verbage on the diagrams to a minimum. We do, however, need to write sufficient notes on the diagrams to ensure that the site factors are communicated clearly. This is more critical when the diagrams are not only for ourselves but for someone else as well (another designer, client, etc.).

Even when the diagrams are only for ourselves it is valuable to compose our thoughts about particular site conditions succinctly and clearly. The writing of the notes helps us to clarify our

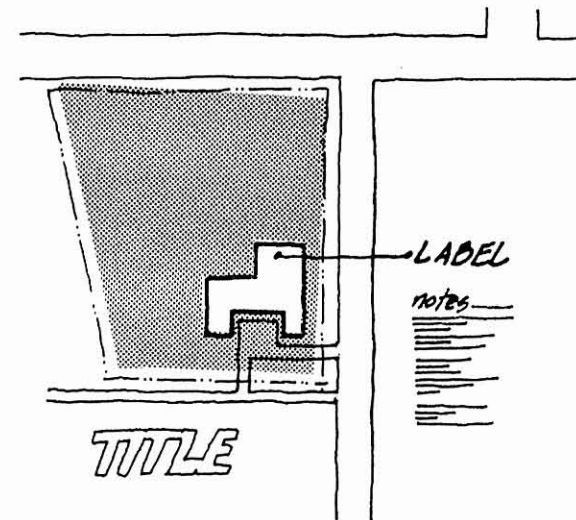

understanding of the site issues, ensures that we engage them mentally and often triggers a range of possible design responses in our mind which can be recorded for later use in conceptualization.

Notes on the diagrams should be related to the graphics as systematically as possible. Because the diagrams are segregated from one another, are relatively simple and usually numerous, the placement of the notes

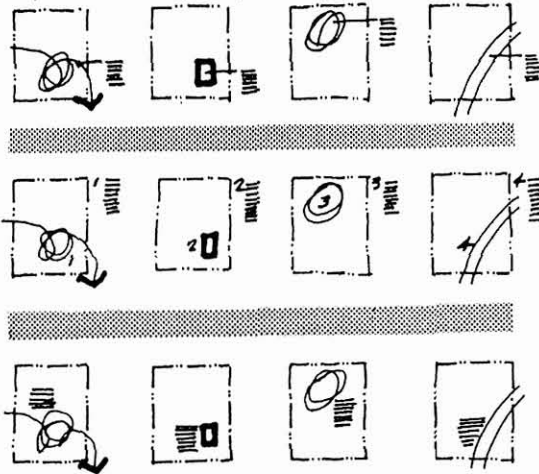

or labels in relation to the diagrams should be as patternized as possible. We want to strive for the same consistency with the notes as we did with the toning or coloring of the graphic essences of the diagrams.

The diagrams need to be titled and labeled. Titles and labels should be consistently located in relation to the diagrams and relate hierarchically to the major titles on the overall analysis sheet page or board. A

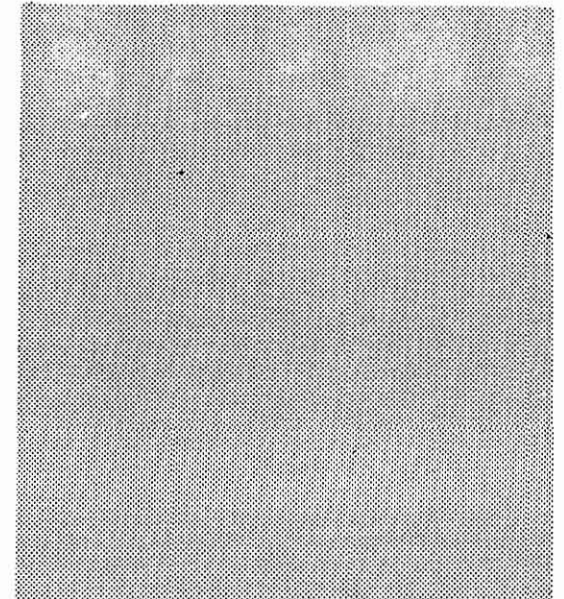
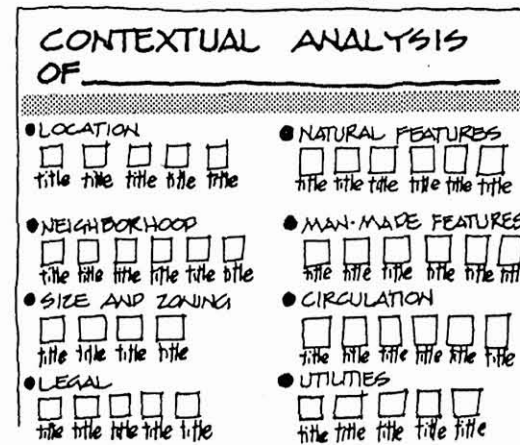

**TITLE OF PROJECT**  
**TITLE OF DIAGRAM FAMILY**  
**TITLE OF DIAGRAM**

Label of Elements in the Diagram  
 notes

title may relate to a single diagram, a family of diagrams and to the entire analysis.

Letter size and style are important considerations in writing notes, labels and titles. There should be some sense of relative importance between title, label and note expressed through letter size, upper and lower case letters and/or lineweight. Usually the order of importance (from greatest to least) runs from titles to labels to notes.

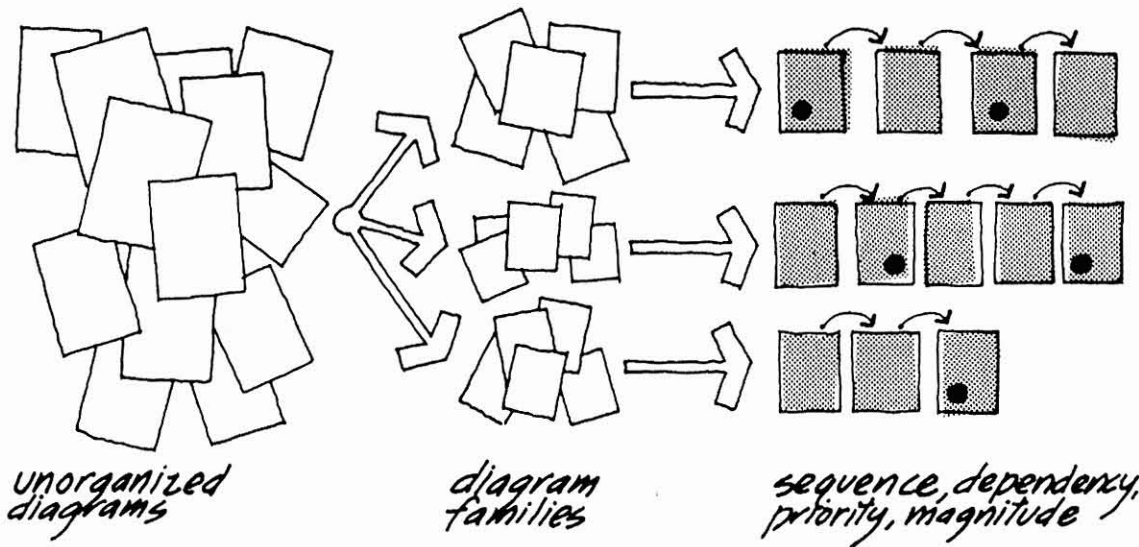

## ORGANIZING THE DIAGRAMS

At this point in our contextual analysis we have several diagrams, complete in themselves but not in any particular order or arrangement. The next step is to put the diagrams into some meaningful order. This is a valuable operation for us as designers because it will give us the opportunity to establish a sense of hierarchy and dependency among the issues we have collected and recorded. It is not only valuable but mandatory that we organize our diagrams if we are to communicate them to someone else.

As in any organizational task our first effort must be to define the ways in which the organization may occur.

There are usually several techniques available in organizing any set of elements and this is true for site data as well.

Typical organizational devices that may be used in ordering contextual information are:

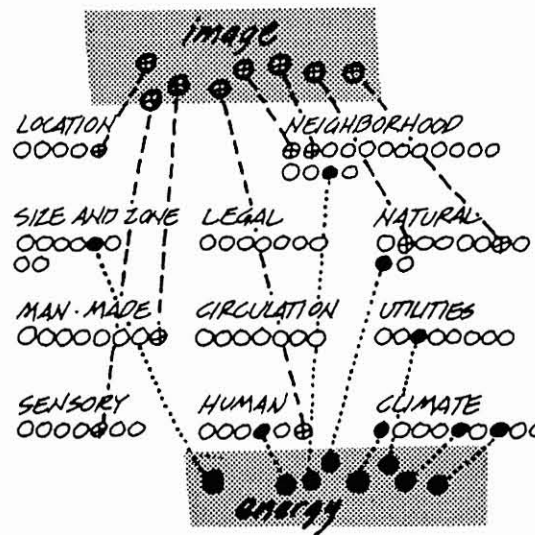
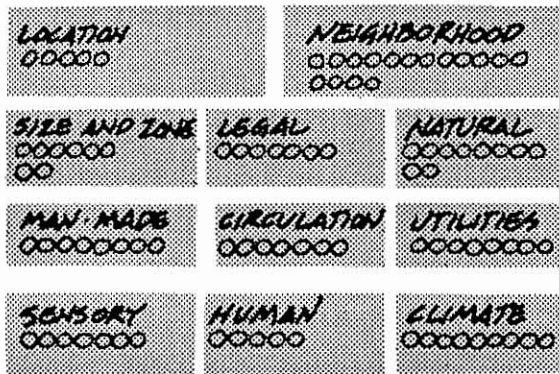

**SUBJECT CATEGORY** We began our analysis using the information labels of Location, Neighborhood Context, Size and Zoning, Legal, Natural Physical Features, Man-made Features, Circulation, Utilities, Sensory, Human and Cultural and Climate. Once we have our data, we need to decide whether these labels still represent the most meaningful and appropriate headings for our information. Sometimes there are ties and affinities between site diagrams that cause them to cluster differently, thus prompting the need for new informational

headings. Redefinition of our informational labels can often be a rich source of new perceptions about the site issues and about how best to respond to them in design.

**QUANTITATIVE-QUALITATIVE** Frequently, as designers, we may want to separate the site information into "hard data" and "soft data." This provides us with a sense of those aspects of the site that are not negotiable, that cannot be compromised and that must absolutely be addressed early in design. These are the "givens" in the project from the site point of view and are not open to interpretation or conjecture. This method of organization also identifies the soft data that is not quantitative and that is available for interpretation by us as designers. "Hard" and "soft" in this instance do not separate the data into facts and non-facts but rather into ranges of mandatory attention by the designer in conceptualization.

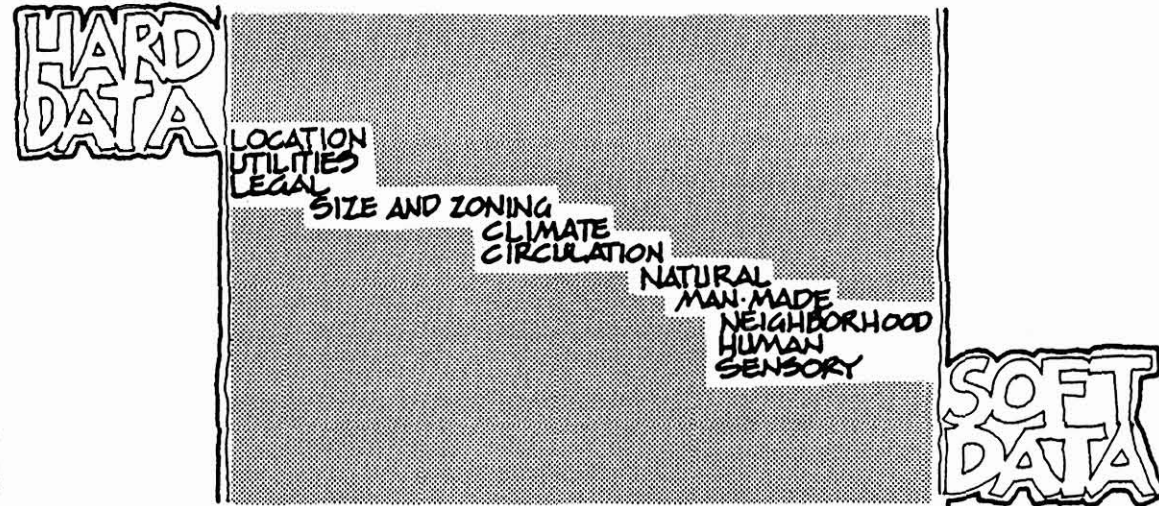

**GENERAL-PARTICULAR** In this organizational approach, we begin with site information that provides understanding on an overview level and proceed to an elaboration of that information on a more detailed level. The advantage here is that the more detailed level is provided an informational context by the general level.

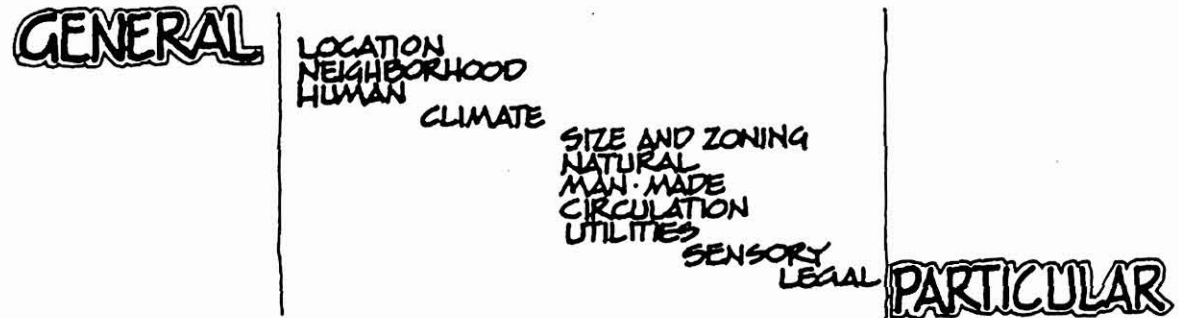

**RELATIVE IMPORTANCE** After finishing our diagrams and knowing the nature of the project to occupy the site, we should have some feel for which contextual factors are likely to be the major influences on the design. These influences can be on many levels and apply to several design issues such as optimum placement of functions

on the site, internal building organization in response to site factors, extent and location of building transparency in relation to climate and energy, form, image and materials in response to existing surrounding buildings and so on. Our knowledge of the site and this simulation of potential influences may prompt us to organize the contextual data in an hierarchical manner.

**SEQUENCE OF USE** This rationale for ordering our diagrams relates to the previous one. Here we anticipate the sequence in which we are likely to need the data in design. This can never be established on an individual diagram basis but may be attempted on a diagram grouping level.

**INTERDEPENDENCY** The individual facts about our site are usually dependent upon one another in varying ways. Site drainage patterns are governed by or dependent upon the site contours as are views from the site when the site has significant high points. This method of arranging our diagrams requires that we first study the dependencies between the various site characteristics and then arrange them from most governing to most governed. This organizing approach achieves a sense of logical site data sequence by always presenting information within which or out of which other information emerges or finds validity. The earlier information provides a framework for discussing the later information. We find in this technique that some site information happens in tandem in a series of related and interdependent diagrams while other site information has no obvious relationships and may be presented independently.

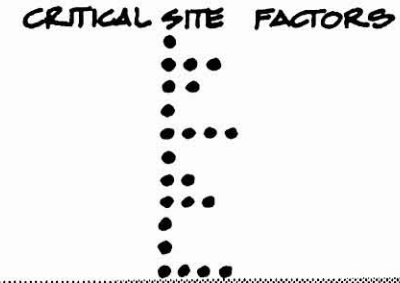
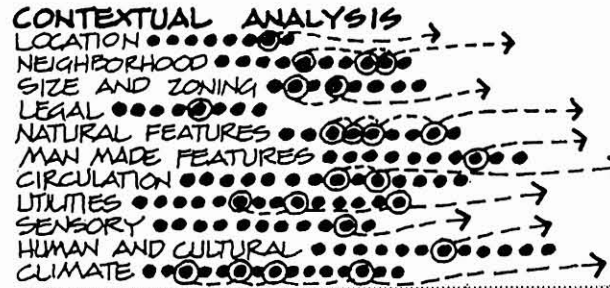

ADDRESSED 1 <sup>ST</sup>	ADDRESSED 2 <sup>ND</sup>	ADDRESSED 3 <sup>RD</sup>
LOCATION LEGAL CIRCULATION SENSORY CLIMATE	NATURAL LOCATION UTILITIES SIZE AND ZONING NEIGHBORHOOD	SIZE AND ZONING CIRCULATION LEGAL NEIGHBORHOOD

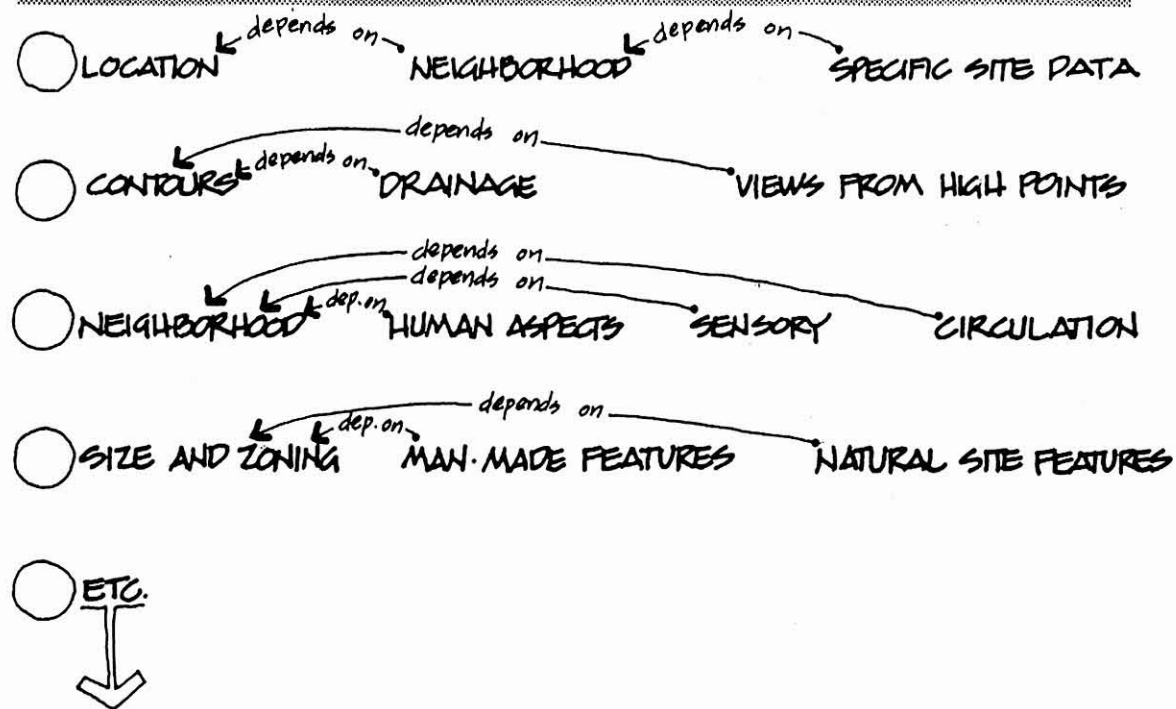

We might find it beneficial to quickly try each of these organizational approaches to see which seems to fit our project situation best. We may discover significant overlap and similarity in the site fact displays that the various approaches show us. It could prove advantageous to adopt a hybrid of these ordering techniques.

**Each of the ways of organizing site information provides us with different labeling systems which in turn influence our view of the site and contextual issues. We very much predispose ourselves to certain attitudes, expectations and vocabularies of design responses by the way we organize our site information.**

It may be difficult to sense the influence of fact labels on eventual design solutions but this connection is definitely present in any project. Our interpretation of the diagrams is structured by the way we have organized the information. As we will see in "Interpreting the Diagrams," the first level of interpretation happens not in terms of individual site facts but in terms of patterns and densities of information occurring as a result of our chosen labeling system.

The formats for actually packaging and delivering the site diagrams (where this must be done) may range from slides, booklets, scrolls, boards and individual cards to models and movies. We should study the presentation situation in terms of our content, audience, purpose, location and timing to determine the most appropriate delivery form for the information. The most

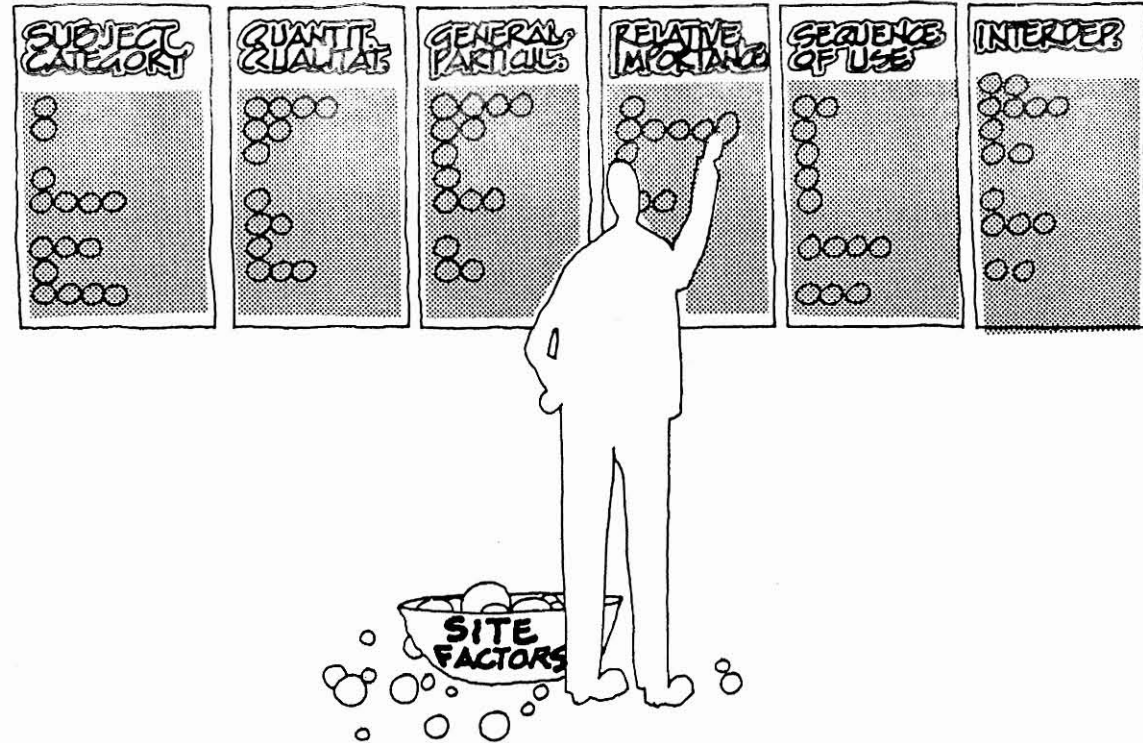

common methods for packaging the diagrams are on a single board or sheet or on cards (3×5 or 5×8). Being able to see all the diagrams together provides us with some interpretive clues when we are ready

to assess what the site data may mean in terms of potential design responses.

The following page illustrates some sample layout approaches for board or sheet presentations.



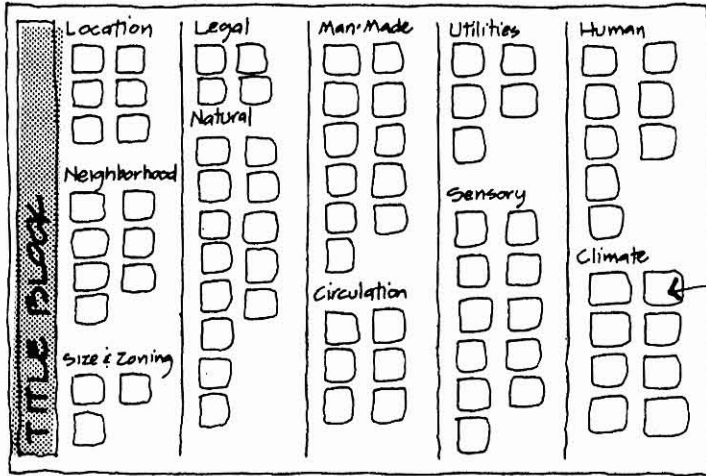

site factor diagram

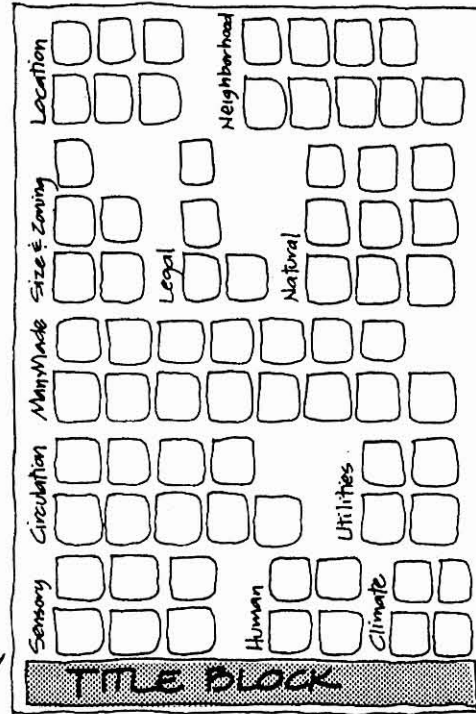

the diagrams may be framed

the diagrams may suggest frames

the frames may participate in the diagrams

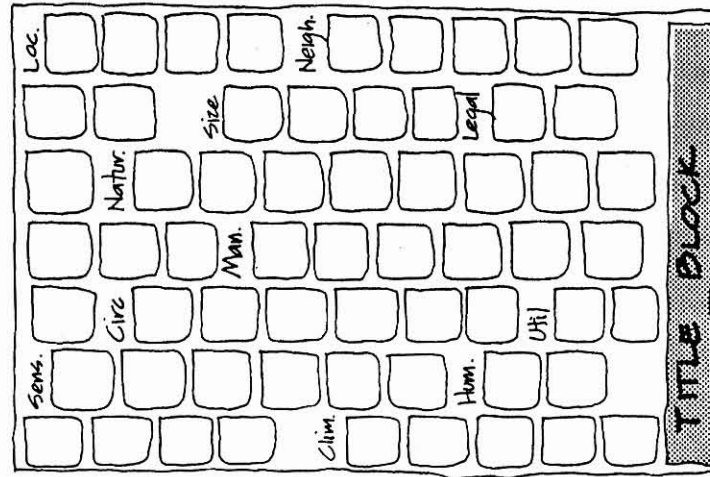
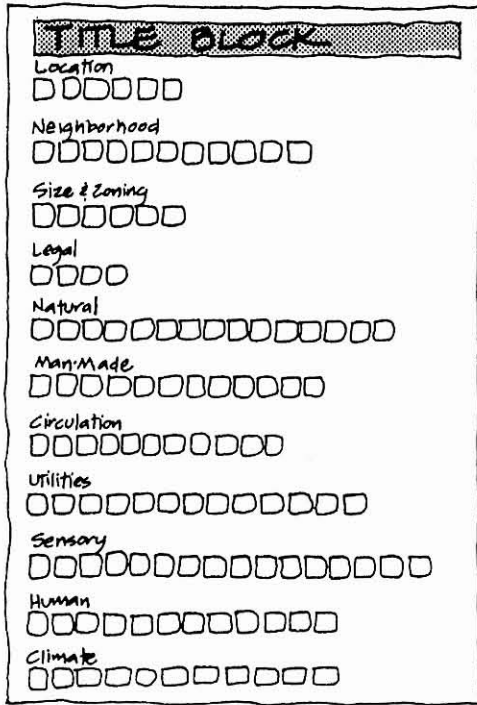

## INTERPRETING THE DIAGRAMS

There are at least three levels at which interpretation of the diagrams may occur. The first is the overall pattern and density of the diagrams as we perceive them as a total on the sheet. The second is the potential meaning of sets of diagrams that deal with a particular issue category (Sensory, Neighborhood) or that comprise a network of issues that transcend issue categories (tree patterns in relation to the framing of views into the site). The third is the interpretation of each individual diagram or site fact.

**Interpretation of the diagrams is our attempt to assign meaning to what we have found out about our site. We are trying to convert data into information.**

As we were gathering the data and diagramming it, we probably thought of possible design concepts for dealing with the various site conditions.

**Interpretation is where we read the diagrams and let them impart to us something about what we may anticipate when we actually embark on design conceptualization. This anticipation is very much a design act since it results in a set of attitudes or postures about dealing with the site and helps us to formulate our strategy for coping with the site conditions in design.**

We can interpret several things from the patterns of the diagrams on our sheet. At this level of interpretation each diagram acts as a vote. By the sheer number of

# INTERPRETATION OF THE DIAGRAMS

## READING POTENTIAL MEANING FOR DESIGN

LEVEL 1

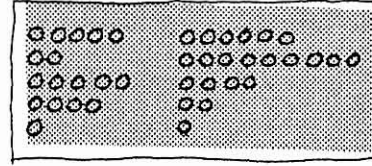

pattern and density on the overall sheet

LEVEL 2

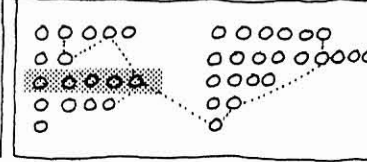
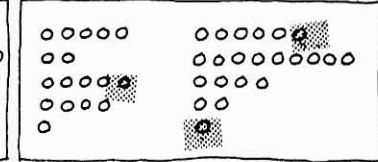

diagram sets or networks

LEVEL 3



individual diagrams

## CONTEXTUAL ANALYSIS

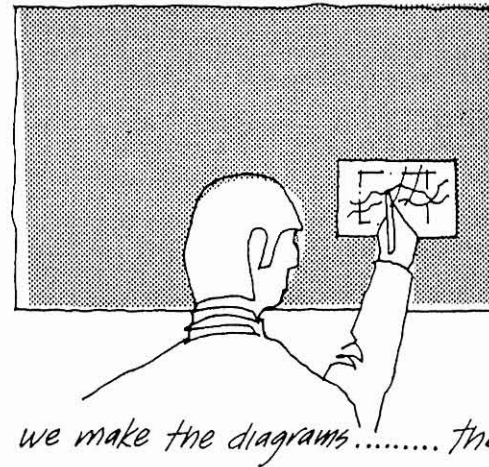

*we make the diagrams..... then..... let them speak to us*

## INTERPRETATION

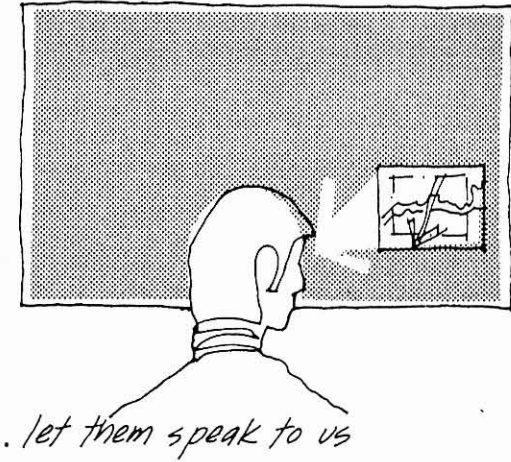

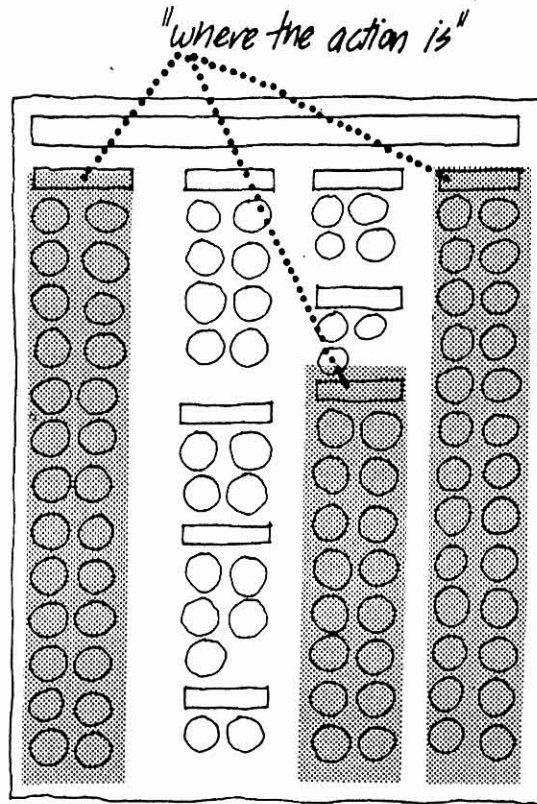

diagrams we have placed under the various information labels (Location, Neighborhood Context, etc.) we are inclined to consider the most voluminous ones as potentially the most important. In a sense, the density of the diagrams provides a preliminary indication of "where the action is" on the site. The density probably represents our depth of involvement in the issues and our sense of the relative importance of the site facts. We tend to spend more time elaborating on rich and potentially important site information and not too much time on issues that we do not feel hold much promise as major form givers. At this level of interpretation we must be alert to the fact that some site information areas simply have more subheadings even though they may be relatively unimportant as influences on form.

**A very fruitful exercise, once the diagrams are complete and organized, is to look for new networks or sets of site issues that may create meaningful clusters of site information. By creatively reassembling site issues we provide ourselves the potential for creative responses and solutions to those clusters.**

This process involves checking each site diagram against each of the others to see if there is some possible meaningful relationship between the two that we did not perceive before. If, for example, we relate the fact that we have a potentially negative neighboring site use with seasonal temperature variation, annual rainfall, site contours and drainage patterns, we may want

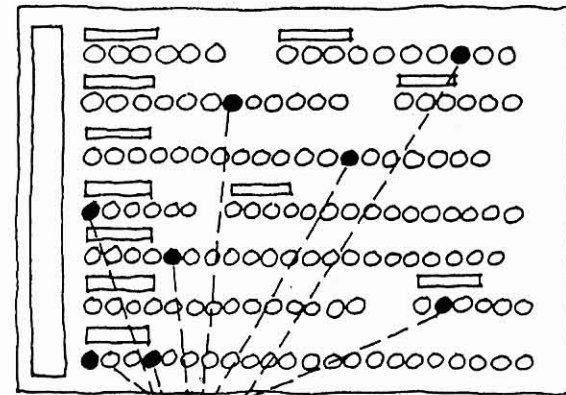

*new site issue cluster*

*new concept in response to the cluster*

to tentatively explore the potential of creating a catch basin to buffer against the adjacent property, control drainage, provide an amenity for our own site functions and establish a beneficial microclimate to conserve energy in our building. This interpretation does not give us the specific solution to that situation but it does give us a situational target to strive for in our design decision making. If our interpretation of the diagram networks can help us establish those beacons toward which to work our concepts, it will have served as a key point in our progress toward the eventual design.

The most common level of interpretation in which we engage is that of the individual site fact and diagram sets within an issue category (Climate, Legal, etc.). By distilling meaning from and/or assigning meaning to each site diagram we are able to predict and anticipate certain things about our eventual design tasks. Some examples of these are presented on the following pages.

1. An overview of the site information together with our perceptions of the actual site tell us whether the site is a demanding one or not. If there are several site issues that constitute a challenge in terms of their size, intensity, value or other quality, we are alerted to that fact in interpreting them and can anticipate those design vocabularies and conceptual families that may be needed to cope with those site conditions. There are some sites which are relatively featureless and which provide little stimulation for us as designers. Where we have one of these we know that the principal form giving issues will have to come from something in the project situation other than site. Other sites may provide single or multiple aspects, intensely positive or negative influences, which can give us a place to start in our thinking about placement of functions on the site.

*clusters of site facts and issues*

*appropriate design responses to site facts and issues*

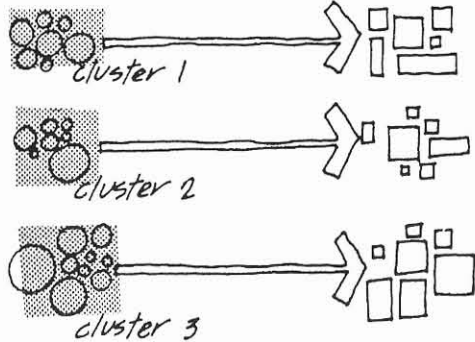

2. Site size in relation to the functional spaces to be placed on the property tells us whether we are working with a tight or loose building to site situation. Tight situations imply stacking of functions (multi-story building and parking) and the need to orchestrate the residual site space to maximum advantage. There can be little wasted site space in this instance and our design routines for handling "tight situations" will be particularly appropriate.

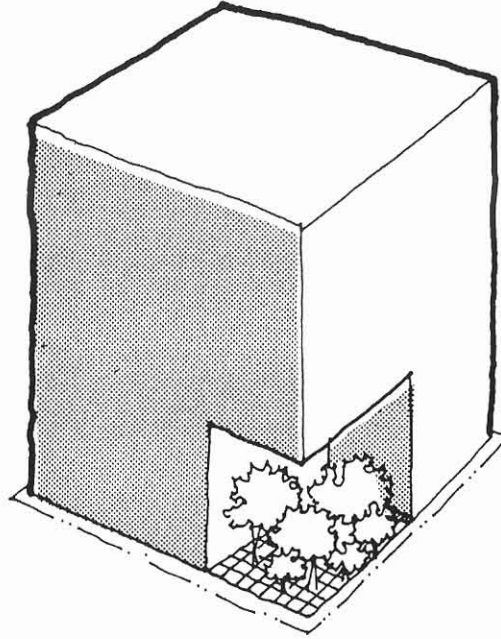

3. There may be a strong mandate from the building forms that surround our property for a particular range of stylistic architectural responses in our project. Where there is a coherent ambience to respect (scale, materials, landscaping, land use density, use of open space, fenestration, roof forms, porch forms, details, accessories, etc.), we must decide our posture with regard to that ambience (contrast or conformance) and focus upon those conceptual approaches that may prove successful in that situation.

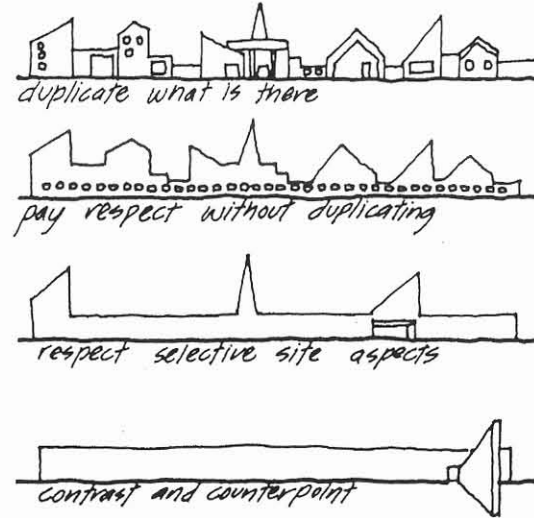

4. Site contours may be very pronounced prompting the anticipation of a stilt building or a significant degree of earth sculpting to integrate the building and exterior functions with the land. Sometimes contours and other surface features (trees, rocks, other buildings, etc.) dictate where certain functions must be placed on the site (playfield on largest, flattest area; parking on low end to avoid drainage problems with building; building on high land to avoid drainage problems and allow slope required to connect building with sewer utility).

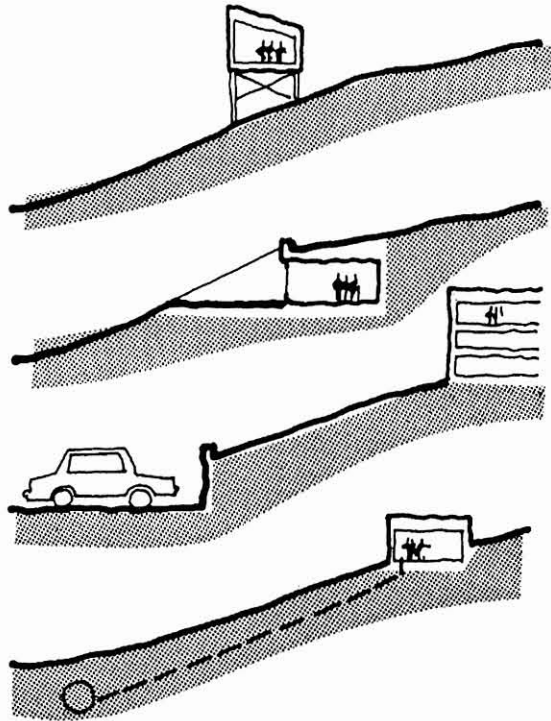

5. Adjacent street and vehicular traffic patterns usually dictate where we can best bring vehicles onto our property. Typical responses here include avoiding access-egress to and from major streets, using minor streets for a safer, decelerated access and egress and placement of the entry-exit as far from street intersections as possible. We may utilize alley ways as vehicular distribution edges when possible. To avoid extensive on site paving of distribution roads, the vehicular entry-exit point normally dictates the general location of parking.

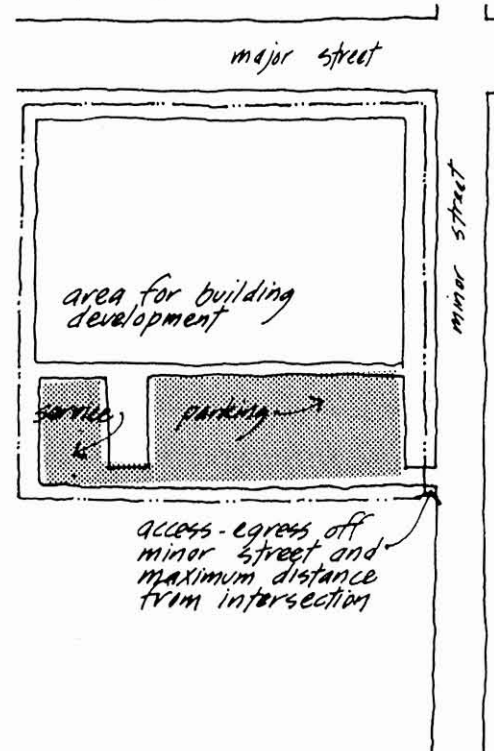

6. Adjacent roads or neighboring functions may be such negative influences on our project that we may want to use parking and other non-people areas as buffer zones between the negative influences and our project.

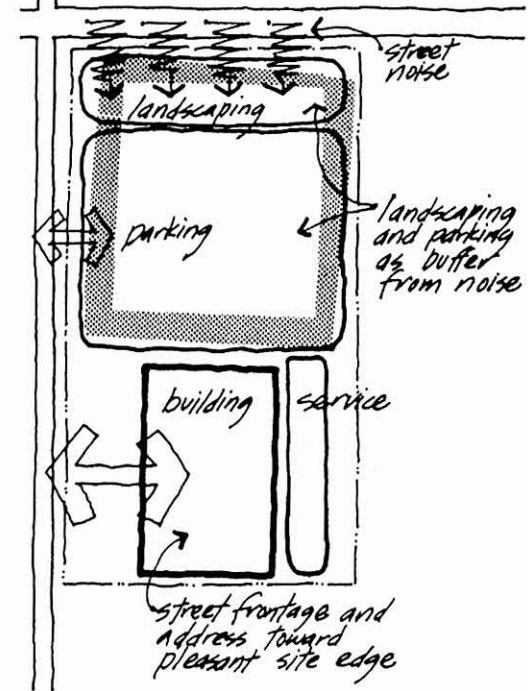

7. The yearly weather conditions may be such that they prompt some form giving concepts. Good weather may suggest an open, vulnerable, porous building and minimal mechanical mediation between human comfort and climate. Severe heat or cold might suggest a more defensive posture such as burying the building, aiming its most vulnerable facade at the least problematic orientation, berming, placing the building on the side of the slope that provides the most protection, or using a roof form that can shed great amounts of water in a short time. Large amounts of rainfall suggest the design of a total water handling network to systematically get the water off the roof and stored or off the site with minimal potential damage to our site and neighboring property.

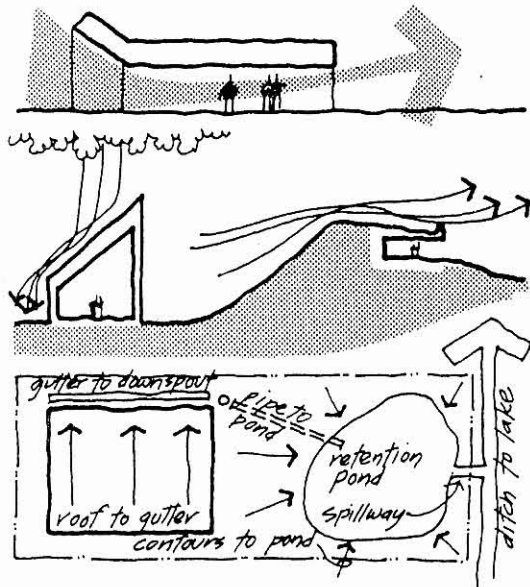

8. Because the area cannot be used for our building, large setback dimensions may often be used for outdoor activity areas and parking.

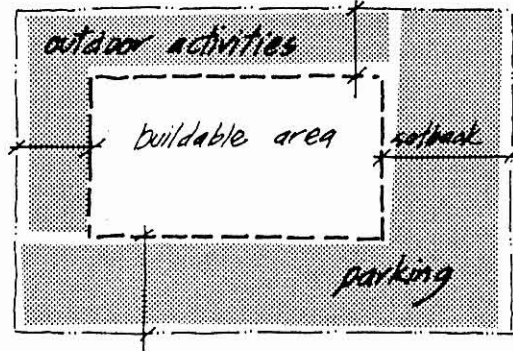

9. Building height limitations and other restrictions resulting from codes and deeds will establish overall massing constraints and oftentimes image vocabularies for our building.

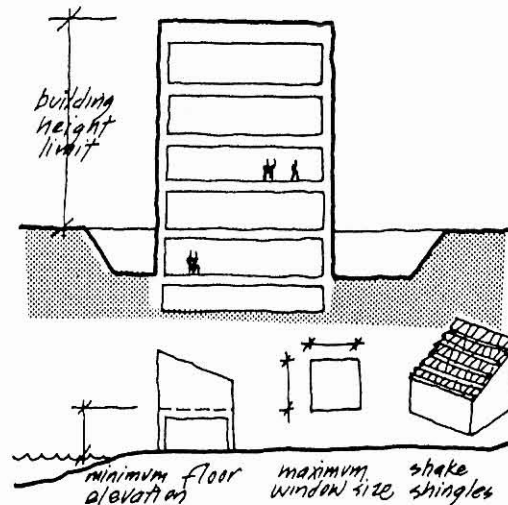

10. In the interest of economy, we may want to place our building near the edge of the site where utilities are available to avoid costly on site utility runs.

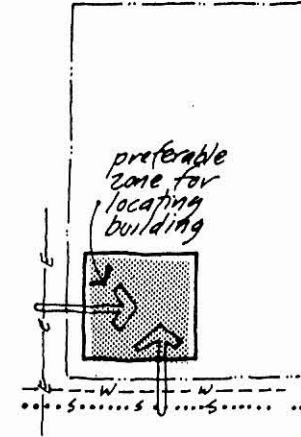

We can see from these examples that interpreting the diagrams in our site analysis is essentially a process of using the site information to stimulate design thinking and to permit the tentative exploration of conceptual responses to that information.

Using the partial analysis of a site and the task of designing a new nursery school, the next few pages illustrate how site design vignettes can be stimulated in response to individual site factors and conditions. These site design vignettes can then serve to evoke concepts for arranging all the client's activities and spaces on the property.

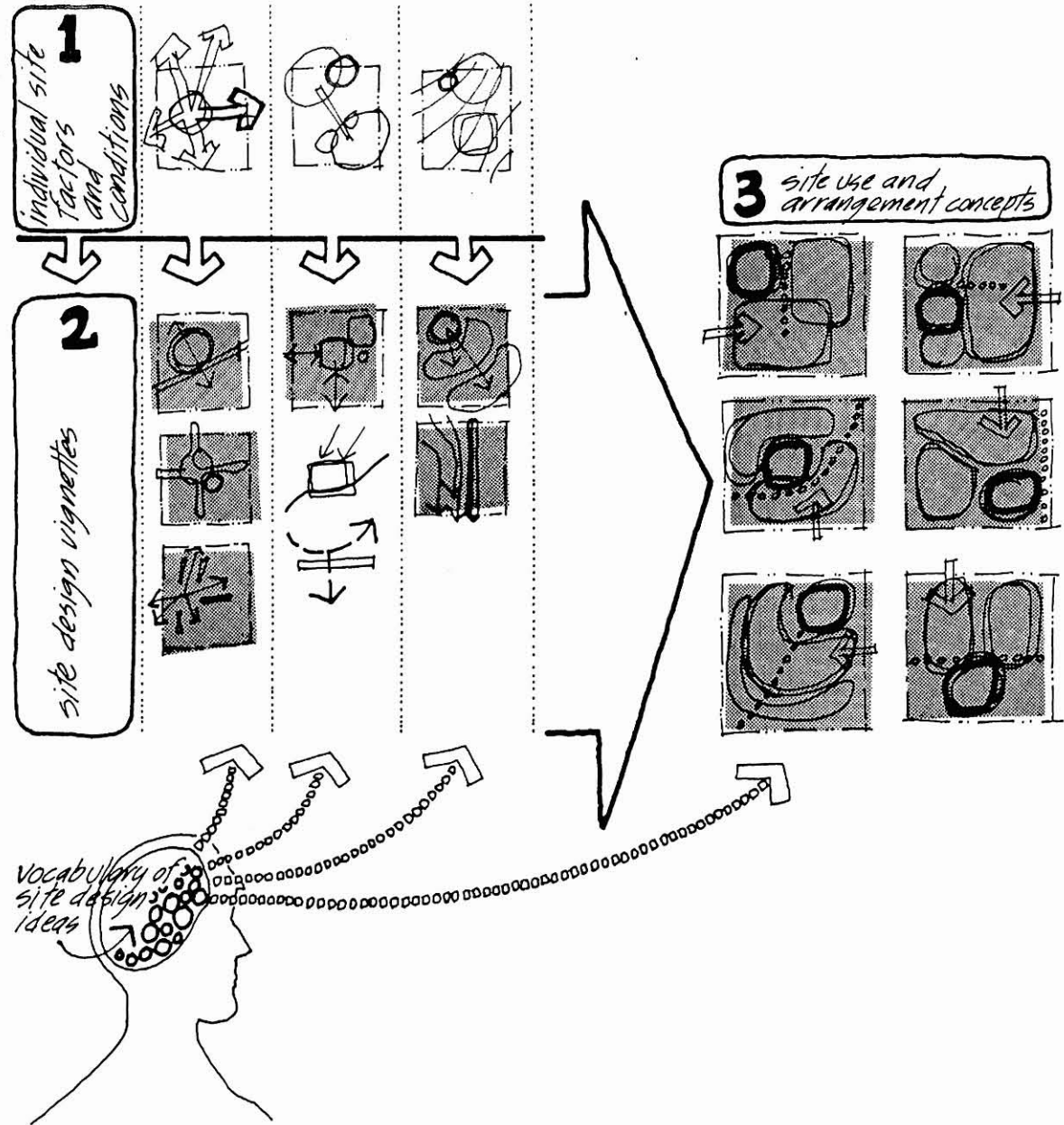

Both the individual site design vignettes and comprehensive site arrangement concepts are drawn from our past experience as designers and our vocabulary of site design ideas that we carry with us from project to project. These ideas are "called up" or triggered from memory by analyzing the various site conditions through diagramming. The more extensive the vocabulary of candidate design ideas we have to draw upon for appropriately responding to site conditions, the more likely we are to produce a successful site plan and building design.



Site Conditions

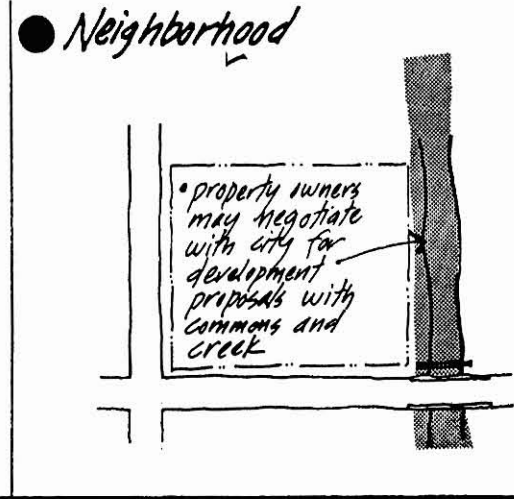
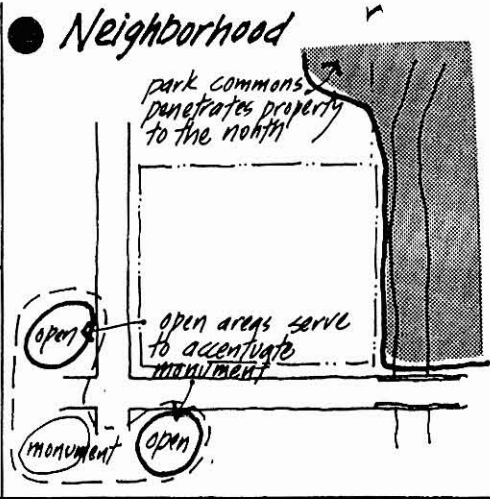
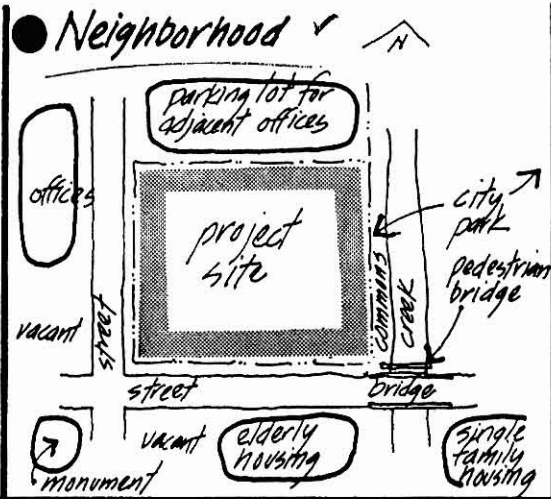

Design Response Vignettes

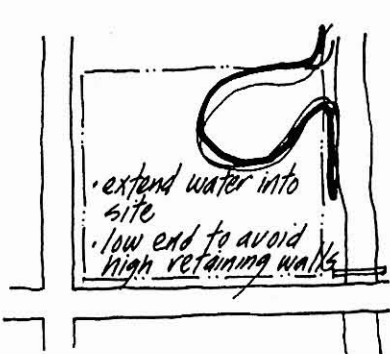
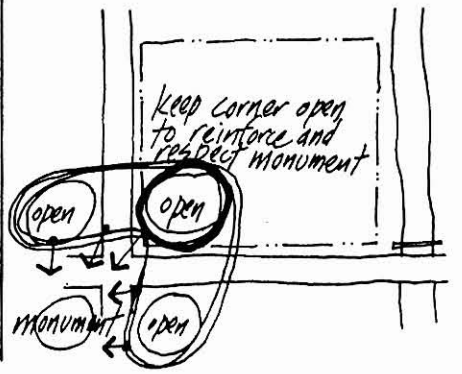
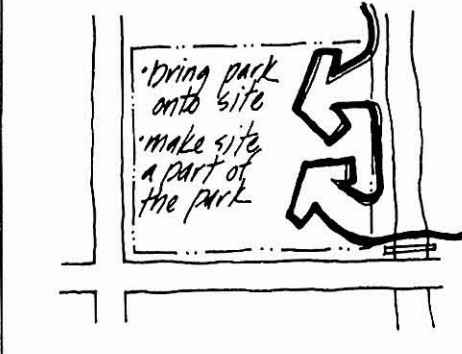
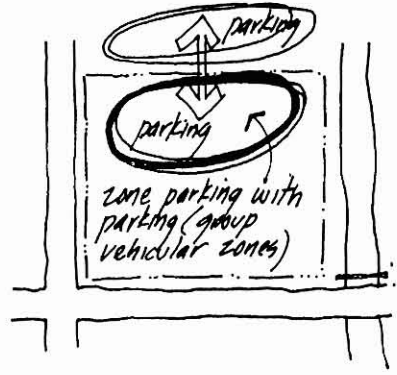
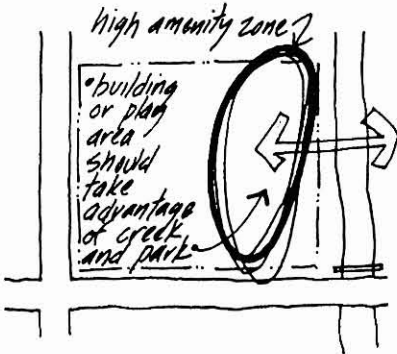

Site Conditions

● Size/Area

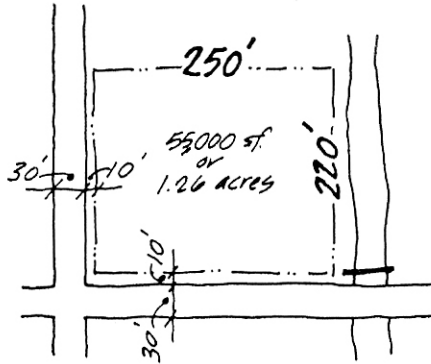

● Setbacks/Easements

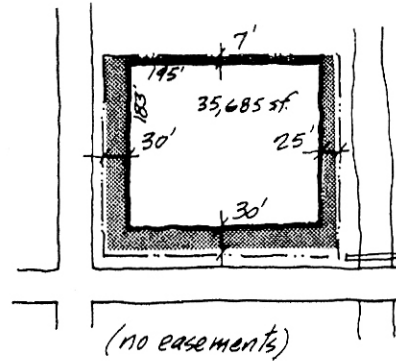

● Contours

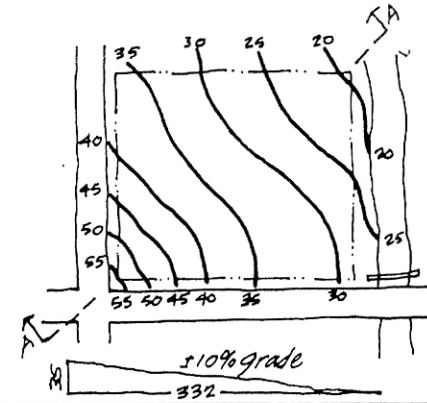

Design Response Vignettes

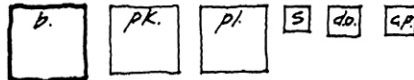

- b. building footprint = 5928 sq ft
- pk. parking (15 cars @ 350 sq ft) = 5250 sq ft
- pl. play area = 5000 sq ft
- S. service area = 600 sq ft
- do. drop off-pick up area = 1300 sq ft (320 sq ft covered)
- cp. covered play area = 1000 sq ft

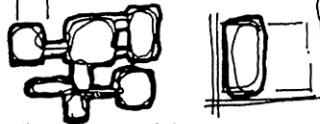
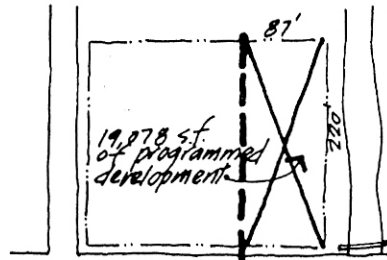

"loose" site situation means building can ramble and there must be concepts for use of "left over" land.

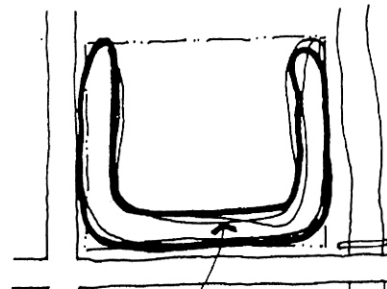

area within setback zone may be used for:

- parking
- play yard
- extension of city park onto site
- extending creek into site
- landscaped buffer

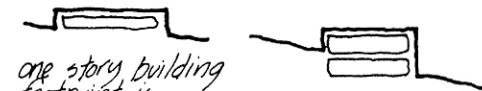

one story building footprint is probable because... internal functions don't lend themselves to a two story solution

building low uses rest of site as background in view from park

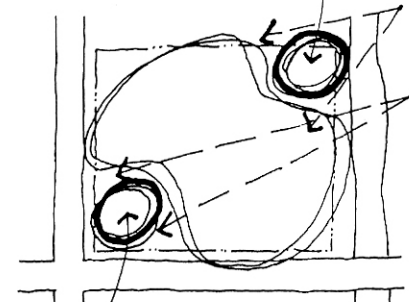

building high uses rest of site as foreground in view from park.

Site Conditions

● Drainage

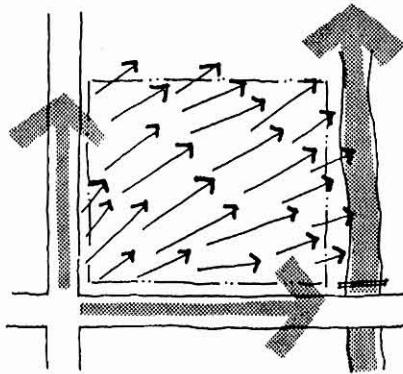

● Trees

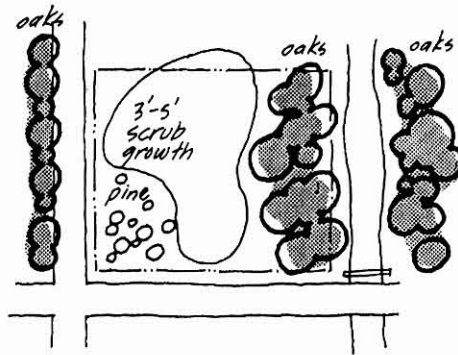

● Man-made features

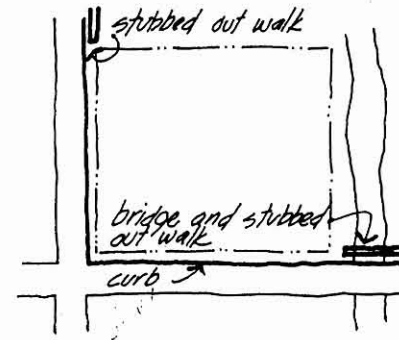

Design Response Vignettes

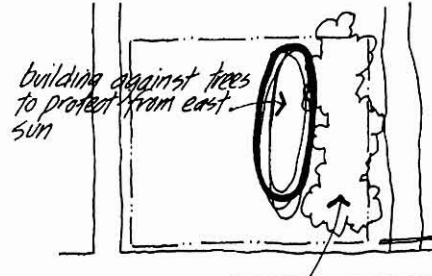
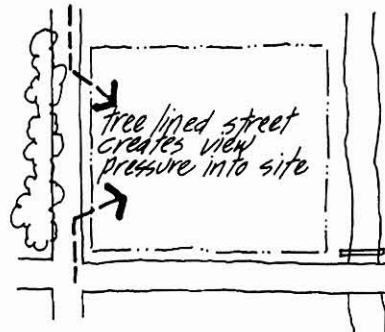
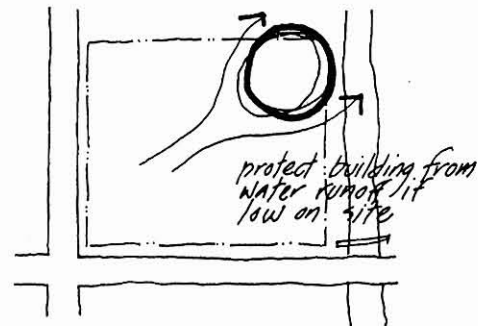
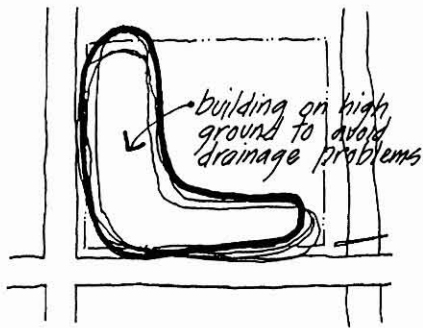

zone tree area as play yard or as extension of park to avoid need for tree removal.

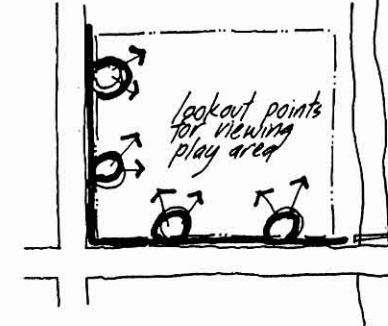
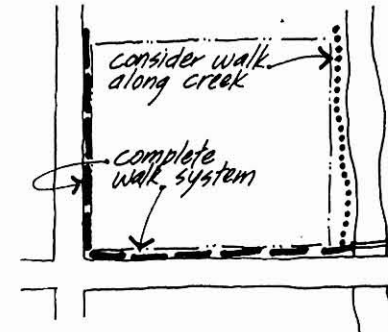

Site Conditions

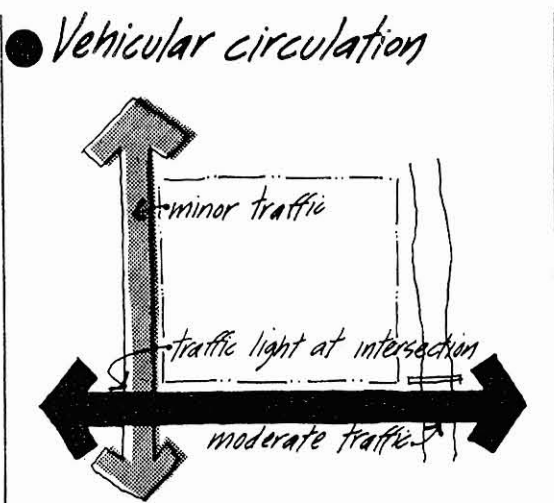
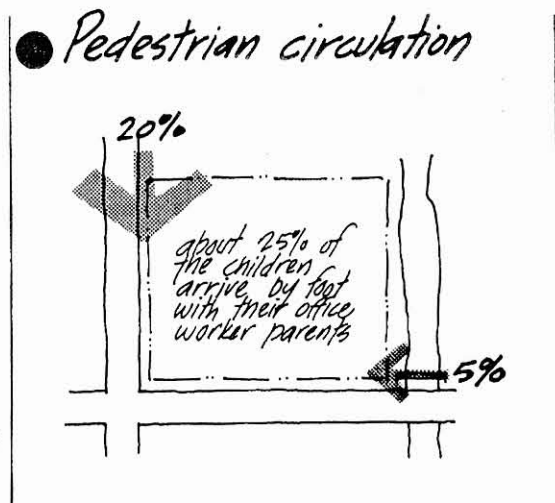
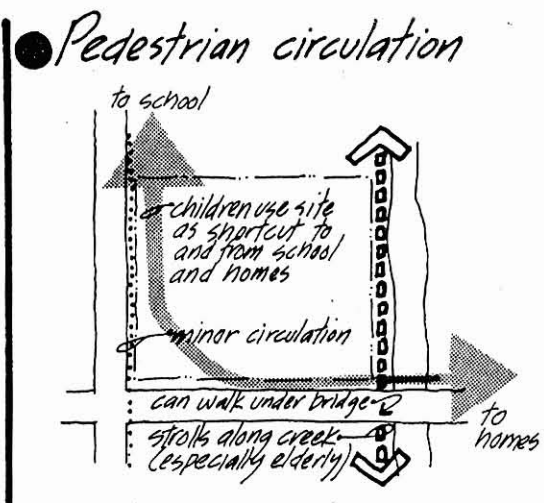

Design Response Vignettes

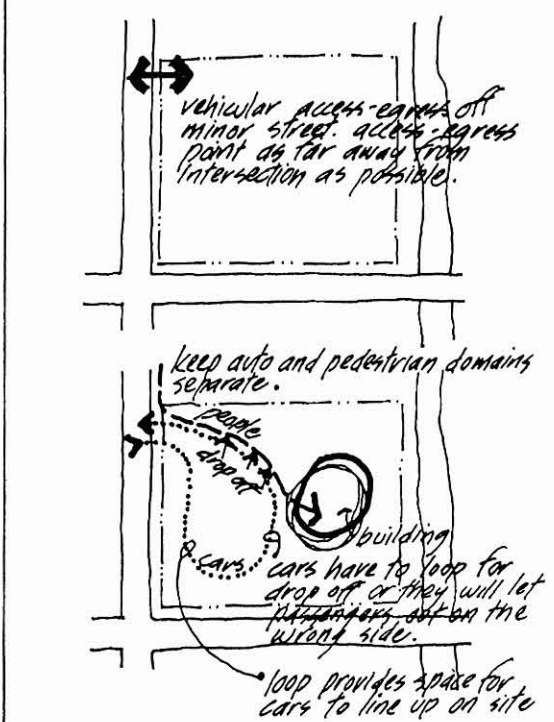
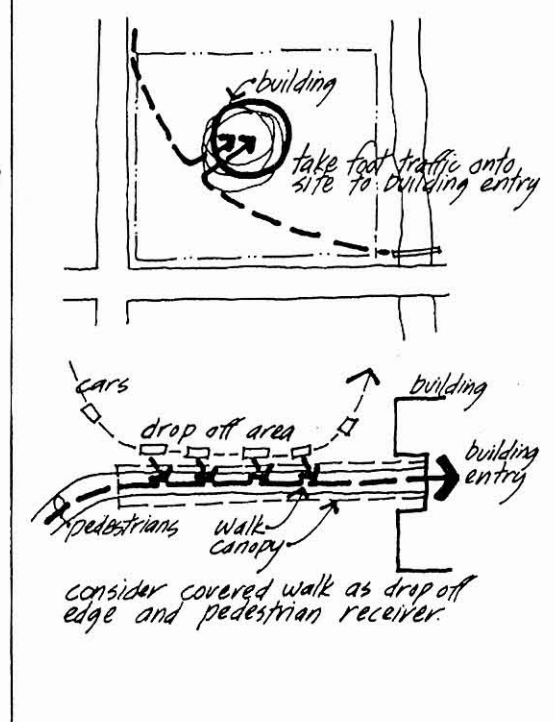
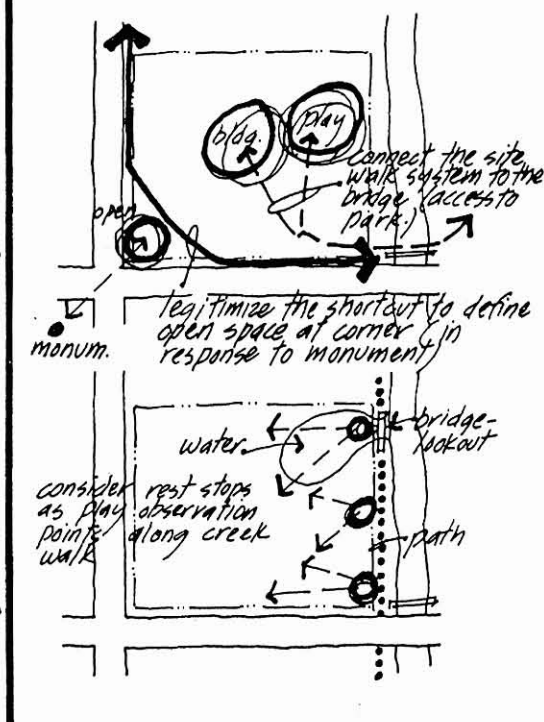

Site Conditions

● Views from site

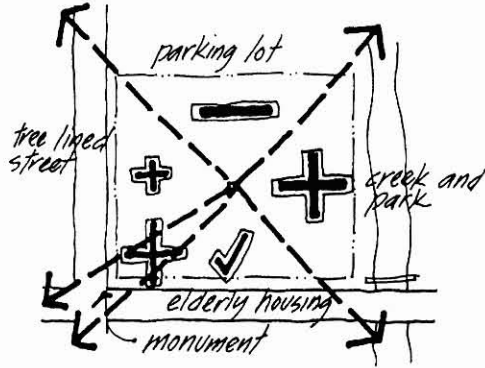

● Views to site

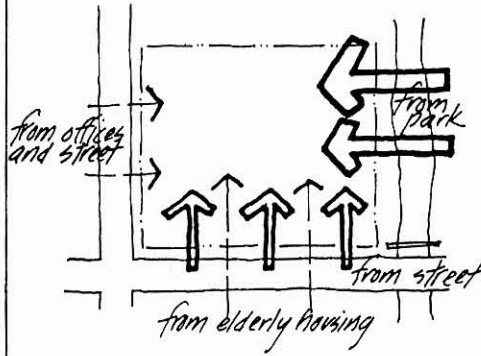

● Views through site

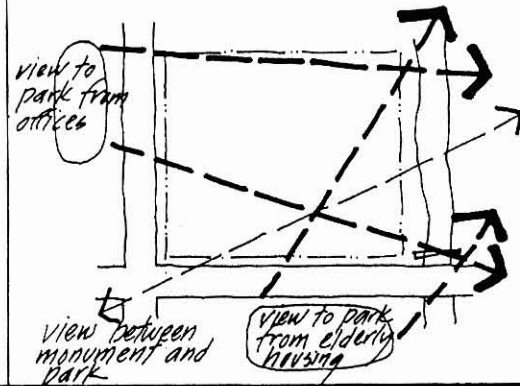

Design Response Vignettes

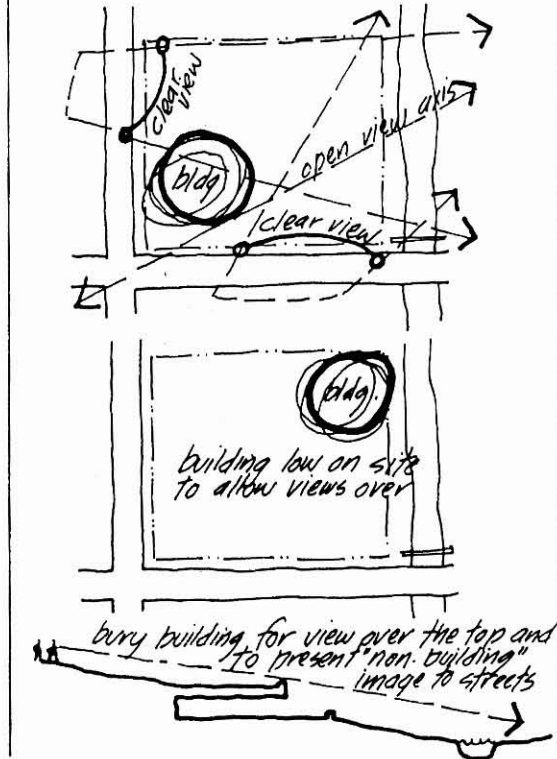
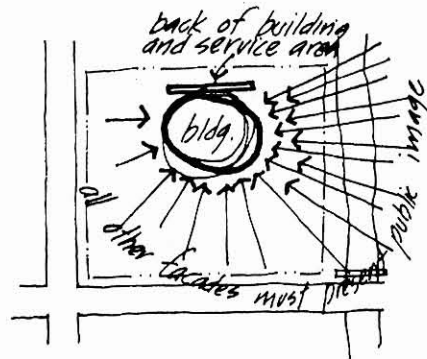
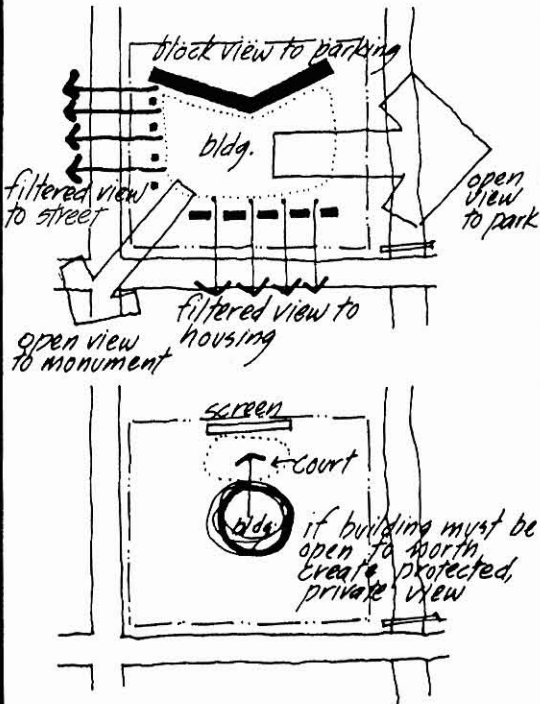

Site Conditions

● Noise

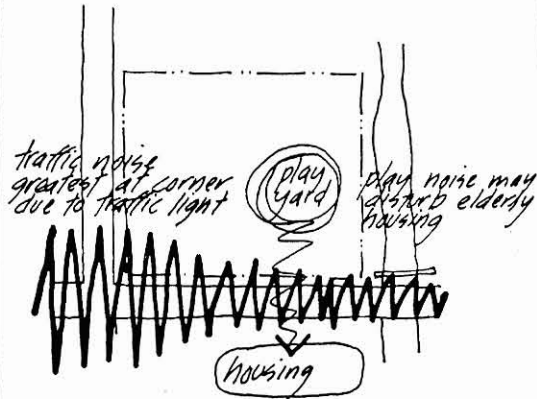

● Human-cultural

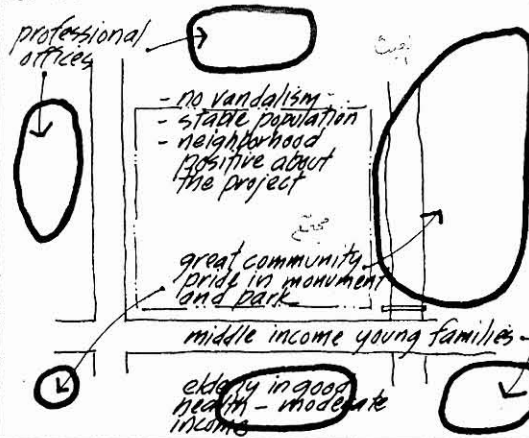

● Utilities

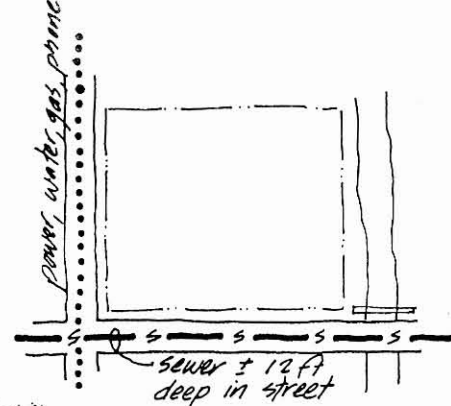

Design Response Vignettes

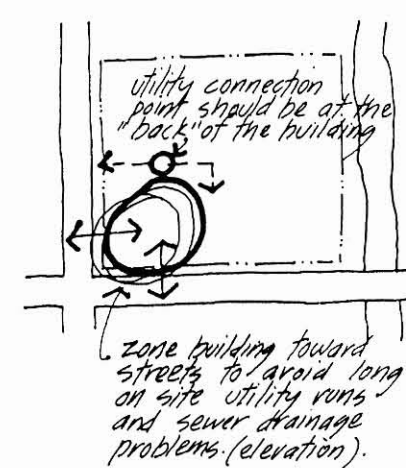
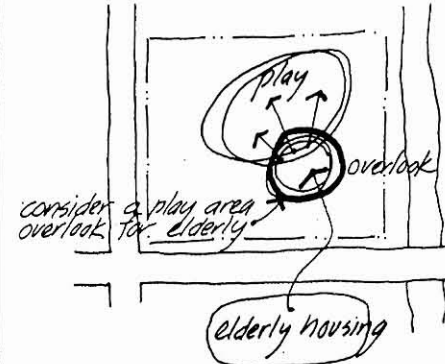
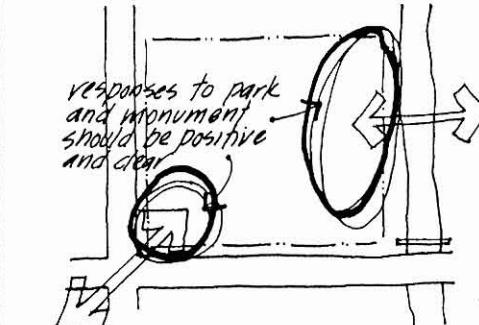
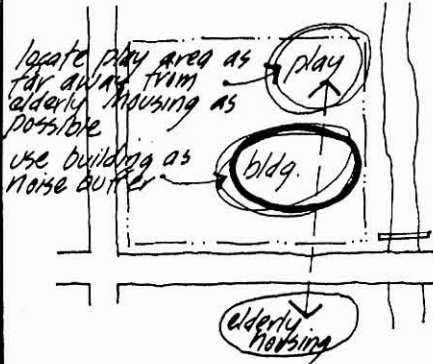
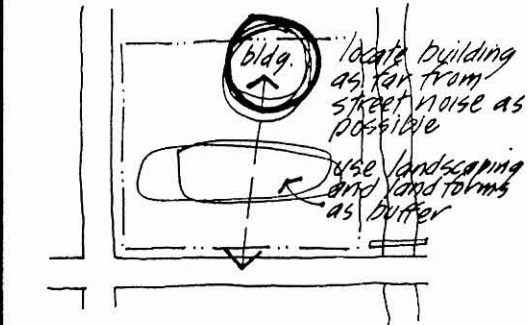

Site Conditions

Wind

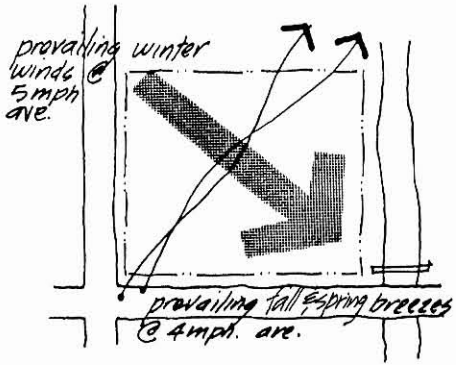

Rainfall

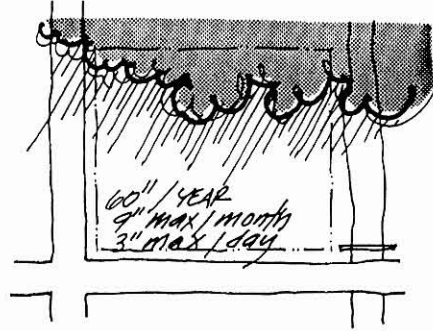

Sunpath

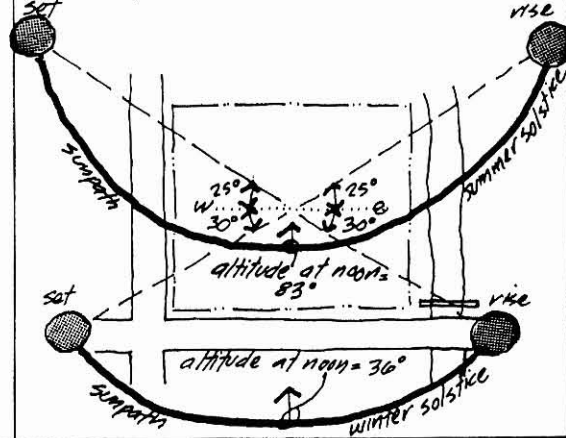

Design Response Vignettes

turn buildings back to cold winter winds

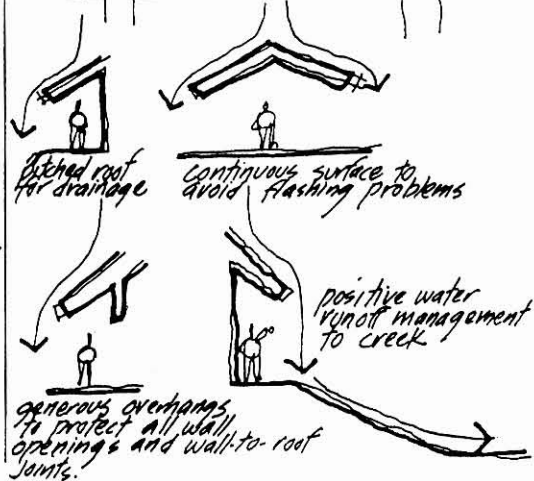
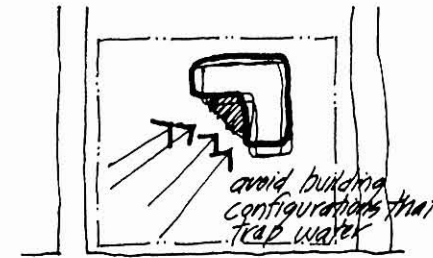
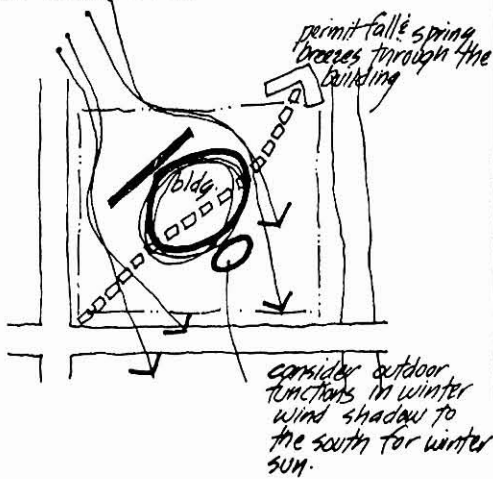

minimal openings to the north to reduce heat loss in winter

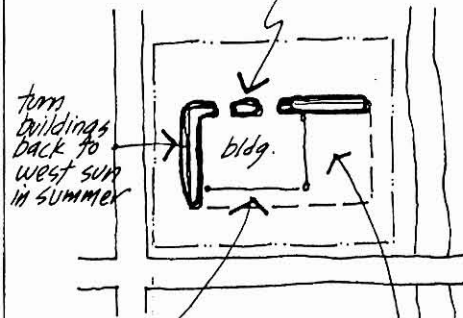

glass to south with shallow overhang to protect from high summer sun and permit penetration of low winter sun.

glass to east with deep overhang and wall to north to protect from rising summer sun and permit penetration of low winter sun.

Site Use Components

- access to parking
- building entry
- [B] building
- [PL] outdoor play
- [PK] parking
- (S) service yard
- (CP) covered play
- (o.d.) overlook-play observation
- [shaded area] major exterior walk system
- [dotted area] minor exterior walk system
- [wavy line] water

Geometries

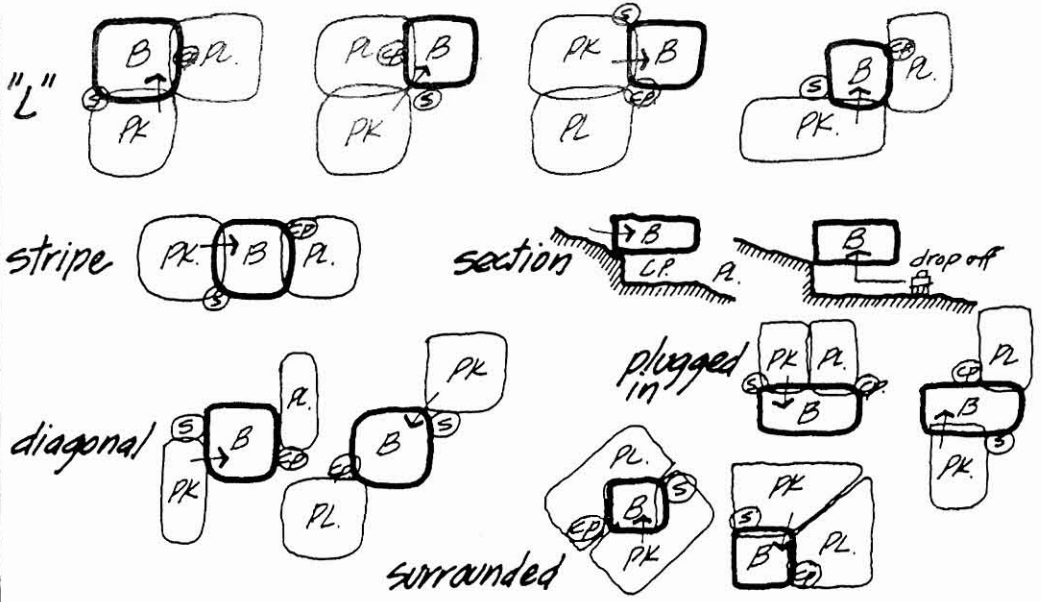

Site Use Alternatives

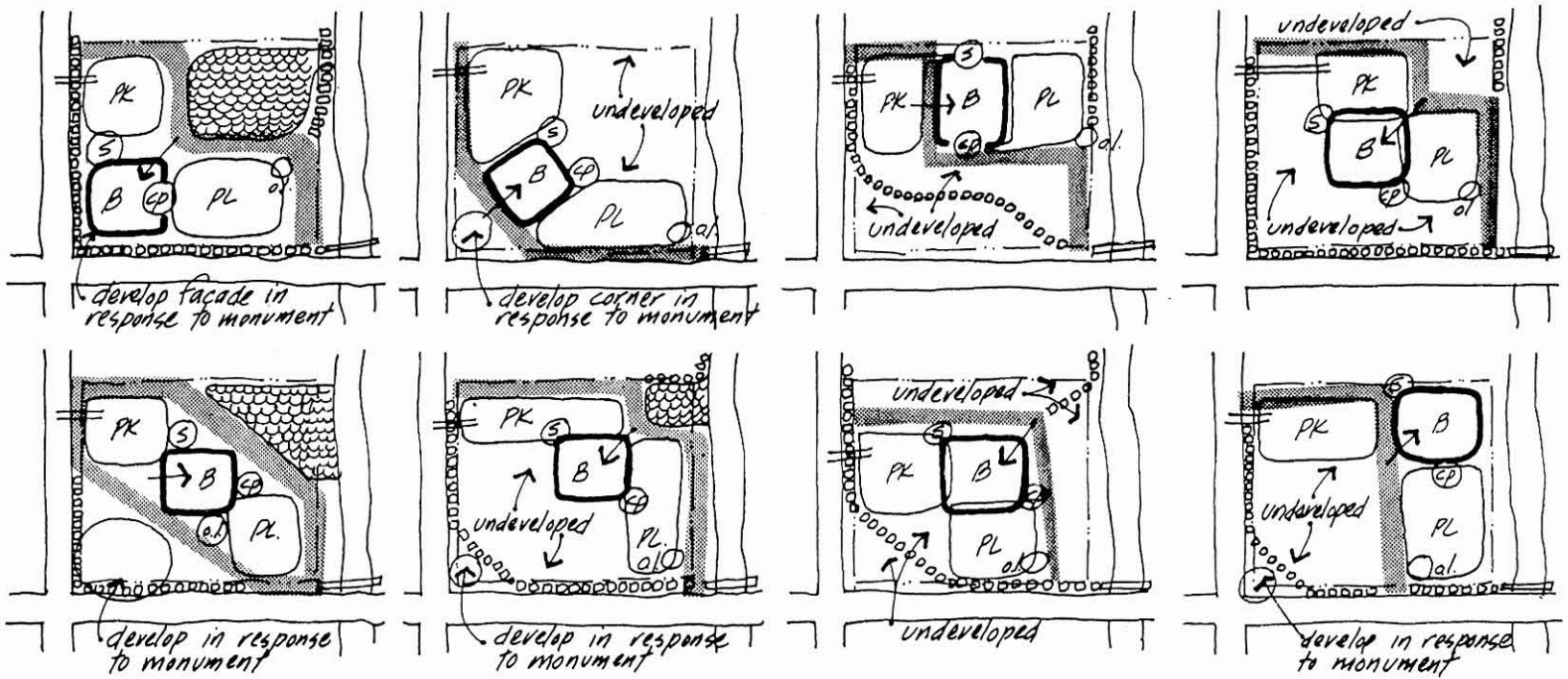



## WHEN TO USE CONTEXTUAL ANALYSIS

Because all buildings have sites, contextual analysis should be part of the programmatic research of any project. The amount of time we devote to the analysis is, of course, dependent upon the time available as determined by office budget and due dates.

**Under the pressure of time we should always choose thoroughness over presentation if something must be sacrificed.**

It is more important to give ourselves a complete understanding of the site situation than to produce finished diagrams of high graphic quality.

The relative formality of our diagrams and presentations is determined by the users of the information. If we are doing the contextual analysis for ourselves it can be very informal and unpolished. Our diagrams can be quick and need not be refined beyond the first efforts which initially record the information. If the site is to be a particularly complex, political, difficult or public issue we may want to document our analysis in a more formal, organized and finished manner because of the relatively demanding communication situation.

It is particularly useful to analyze our site just prior to embarking on the generation of site zoning concepts. Then we are able to take immediate advantage of the catalytic role of the analysis process in triggering design ideas. An intense engagement of site

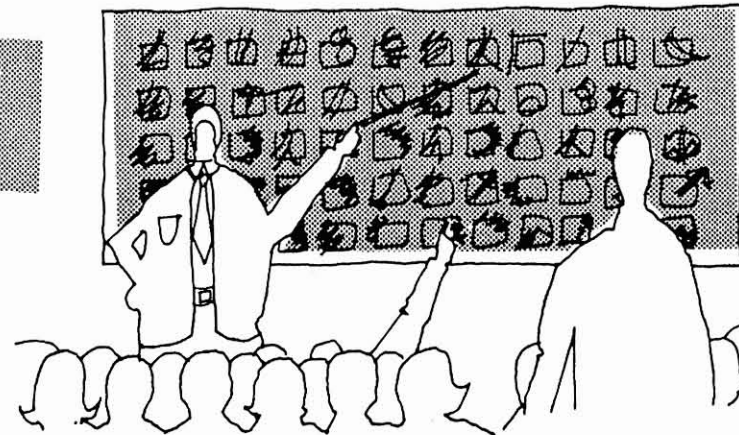
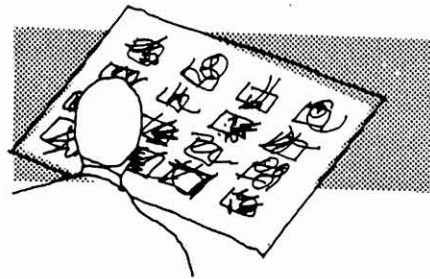
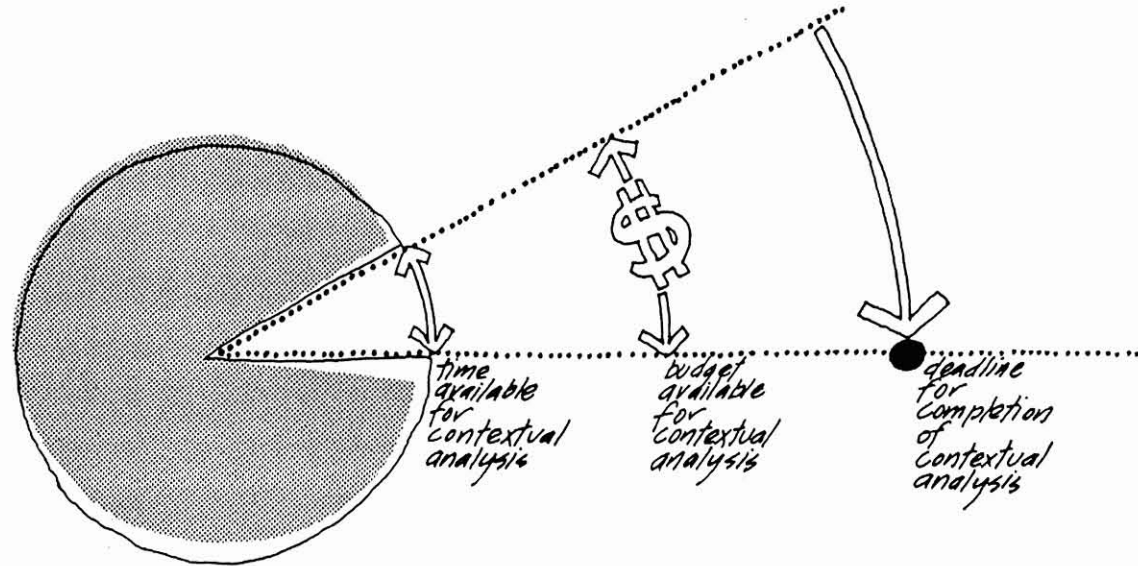

concerns through contextual analysis can stimulate ideas about the optimum placement of major site elements (building, parking, etc.) as well as concepts for migrating

individual building spaces to their most advantageous positions on the site (receiving off service alley, lobby off major sidewalk, etc.).

## OTHER CONTEXTUAL ANALYSIS FORMS

There are several other methods for portraying the information learned through contextual analysis. The analytical technique in these situations does not change from that already discussed. It is the method of presenting or packaging the data that is different.

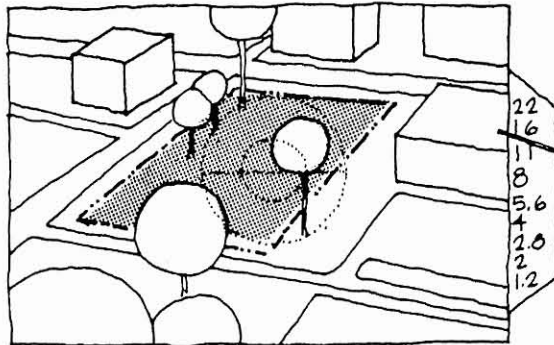

### PHOTOGRAPHS

Photographs can be very effective in presenting information about our site. In addition to the photographic essay which captures the essential ambience on and around our site, photographs can also be used to record all the factual data discussed earlier in this chapter. Aerial photos can be used together with notes and superimposed graphics to call attention to particular site aspects. This can be done using the composite approach (synthesis of information over one large photograph) or the segregated approach (use of several smaller photographs over which to record separate items of information).

**In both these approaches the photographs serve as graphic referents, and as such should be graphically subordinated to the diagrams made over them.**

This can be accomplished by screening the photographs down to a light gray value range through offset printing or by using especially strong and contrasting diagrammatic techniques over undoctored photographs. Where views from the site are

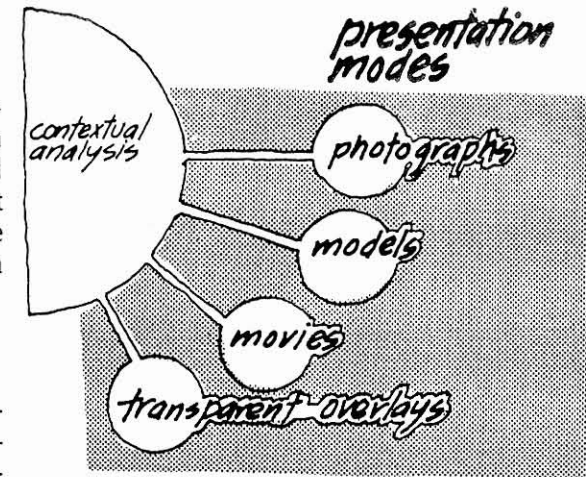

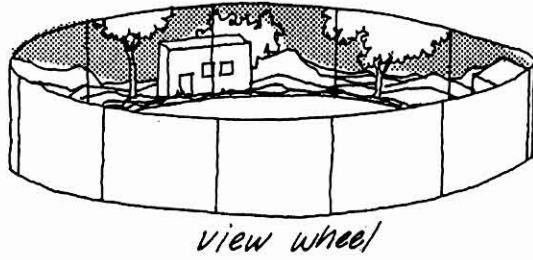

important it is often of value to construct a three hundred and sixty degree view wheel by patching photographs together until the entire circle of views is complete. Photographs are effective in presenting views to our site from various approach directions and for recording significant existing building forms and details in the neighborhood. Where a lengthy street elevation of a series of buildings is important we may patch several photographs together to record the entire elevation as a whole (similar to the approach used for the view wheel).

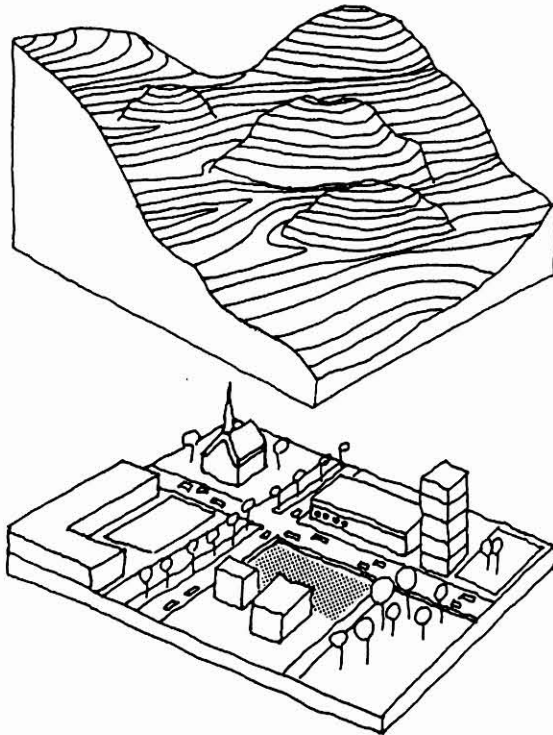
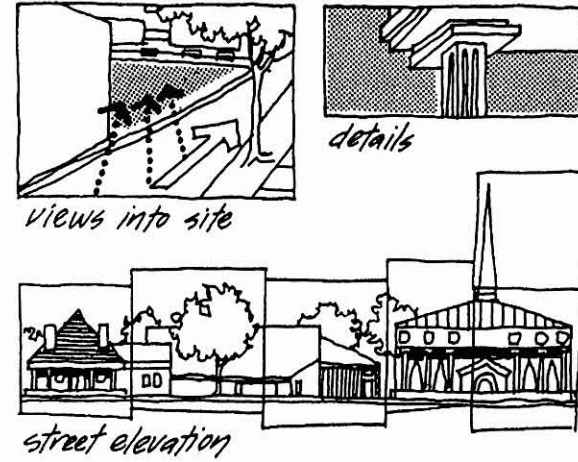

### MODELS

Contextual models are three-dimensional presentation techniques which normally use the composite approach of superimposing all the site information over one referent base model. This method is particularly effective where there are important three-dimensional situations on or around the site that would be difficult to present or understand two-dimensionally. Pronounced land contours, unusual drainage patterns, rock outcroppings and important existing architectural forms are all candidates for presentation by contextual model. Actually, much of the information about the site may still be presented two-dimensionally in the form of diagrams applied to or floating slightly above the contour model. Issues such as boundaries, setbacks, traffic noise and wind can be portrayed diagrammatically directly on the surface of the contour model or on cardboard cutouts applied to the model. Anything having three dimensional characteristics should be presented this way to

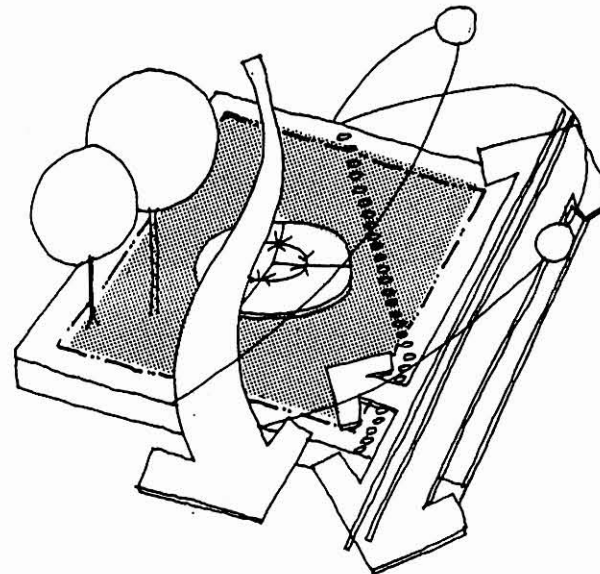

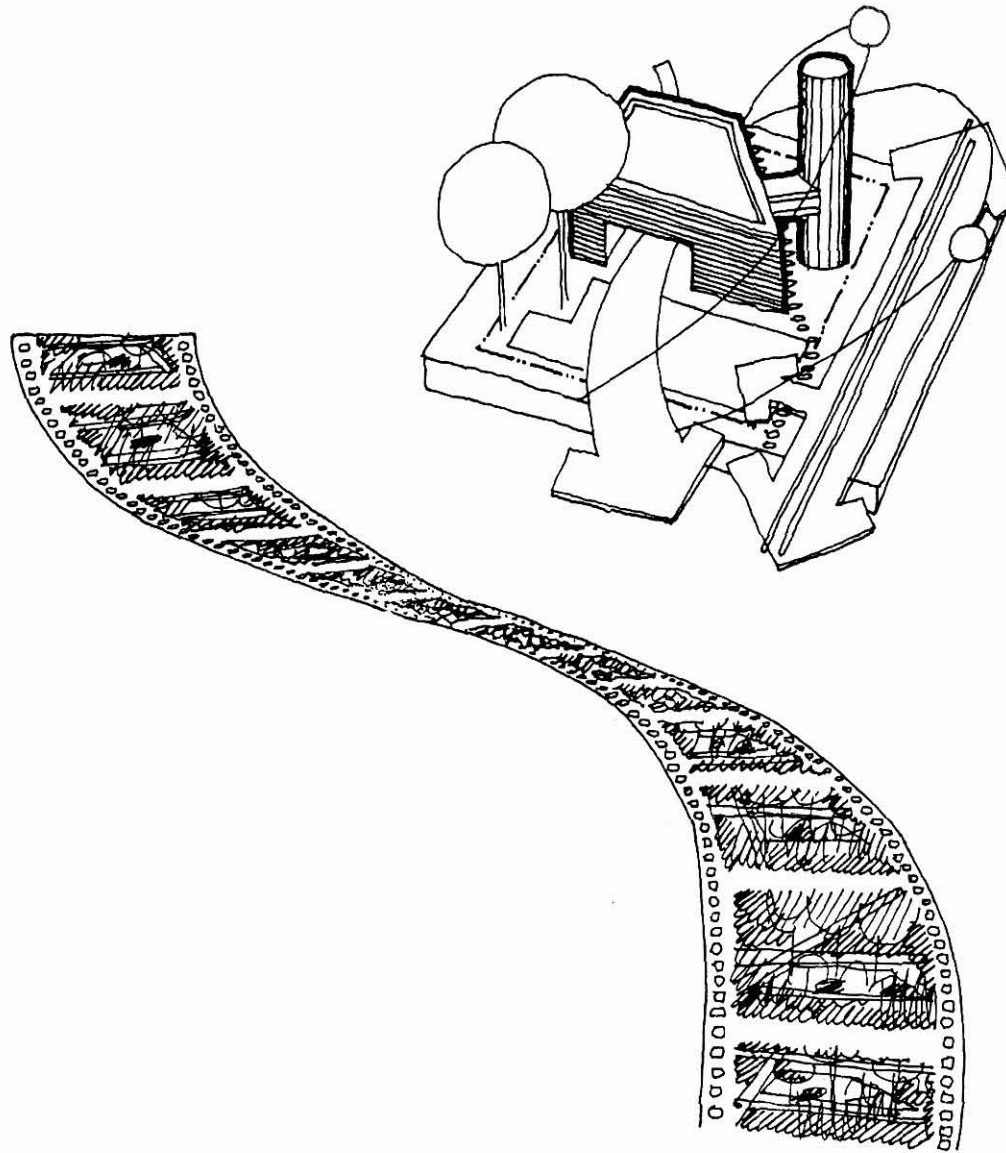

take maximum advantage of this approach. Trees, rocks, man-made objects, structures and sun angles can all be depicted in model form.

**A significant advantage of using the contextual model is that it may be used as a base model for studying and presenting our site concept and building design.**

If this is our plan we should be sure to photograph the contextual model before removing any diagrammatic information and be sure to have made the model at the appropriate scale. It may be of value in later explaining the reasons for our design to leave the diagrammatic site information on the base model together with our design model. This is a very effective way of illustrating why our building design is the way it is and why we feel it is an appropriate response to existing site conditions.

## MOVIES

The movie is sometimes a tempting contextual analysis technique although for many of us not a very accessible one.

**Movies are especially appropriate for presenting kinesthetic aspects of our site.**

Movement to, through, from and past the site, view panoramas, traffic patterns, shadow patterns and sun angles are all appropriately presented through movies. Movies are adaptable to portray evolving or moving diagrammatic information which may be juxtaposed over a base

model. One disadvantage of movies is that they do not package the site information in a very handy desk reference form for design. They are, however, an extremely effective way of presenting contextual analyses to clients or large groups.

### TRANSPARENT OVERLAYS

Transparent overlays offer the advantages of the composite framework approach with the separation and clarity of the segregated diagram approach.

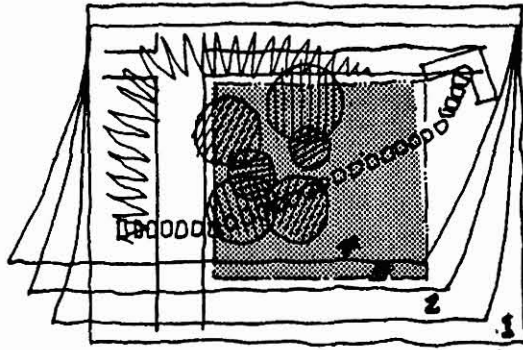

### INTERIOR SPACE ANALYSIS

Another important contextual analysis form which deals with content rather than presentation mode is the interior space analysis.

**This is where we deal with interior space as our project site instead of a piece of land. The major fact categories that we used earlier to organize the individual site data are also useful here although their meaning obviously changes when we move our site indoors.**

The interior contextual analysis is concerned with space, materials, walls, structure, windows, circulation and utilities in an existing building. Listed below are the site information categories that seem to have meaning for an interior analysis and the types of information that may fall under each of the headings. A hypothetical space has been used to illustrate the information. The space is to be converted from a teaching auditorium to open office landscaping.

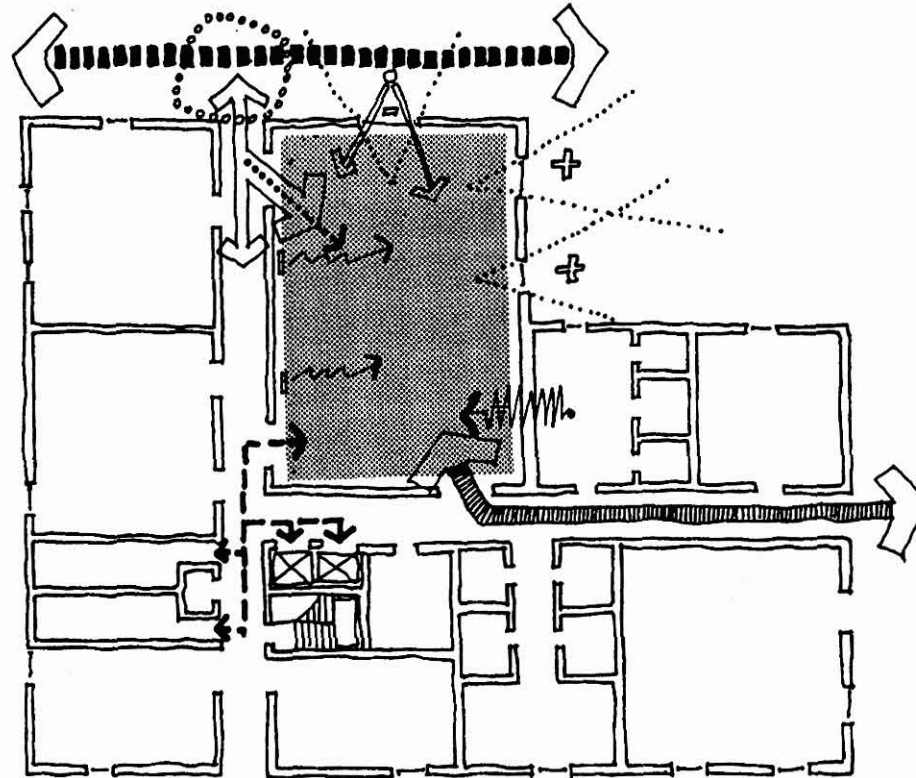

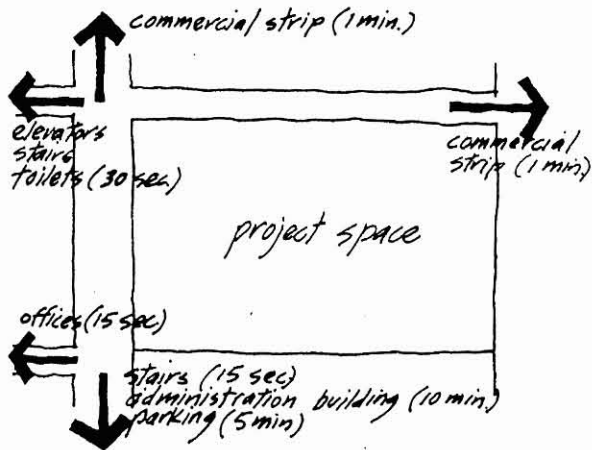
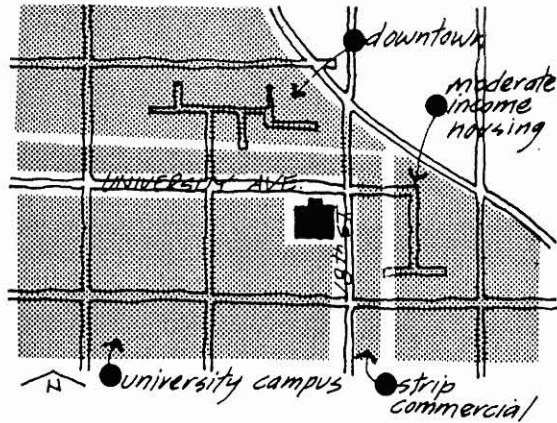

1. Location

a. Location of the building in the city or neighborhood.

b. Position of the space in the building.

c. Distances and walking times to other related spaces inside or outside the building.

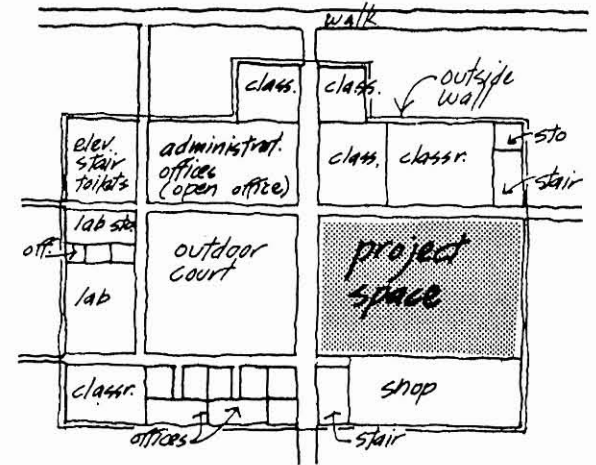

2. Neighboring Context

a. Plan of the space in relation to other adjacent and vicinity spaces including those above and below our space.

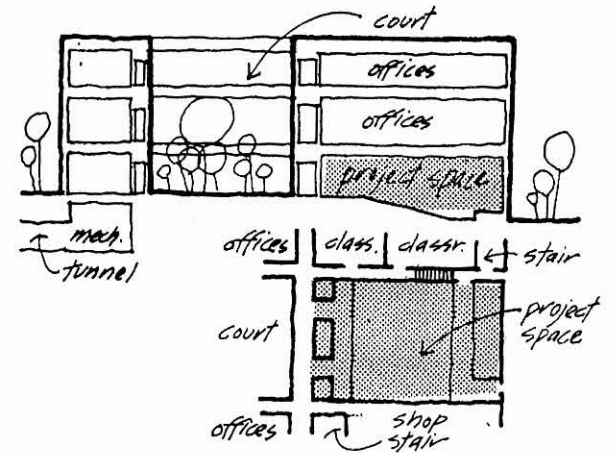

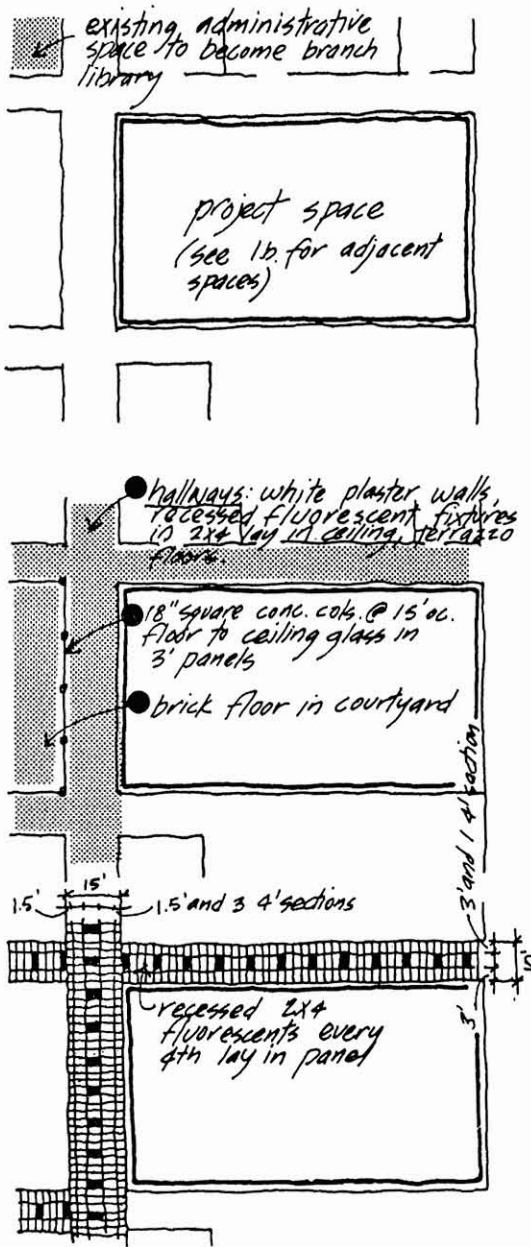

b. Existing or projected uses in the neighboring spaces.

c. Age and condition of the neighboring spaces.

d. Significant architectural patterns or characteristics of neighboring spaces (scale, materials, color, lighting, fenestration, etc.).

e. Special restrictions on the design of space due to interior design restrictions (historic building, etc.).

f. Circulation lighting patterns.

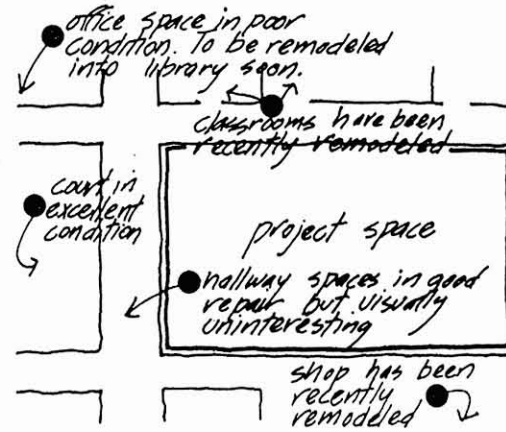

*no special restrictions*

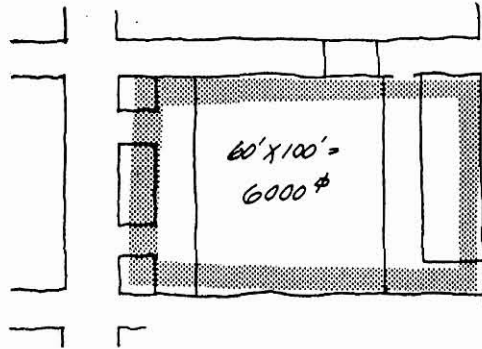
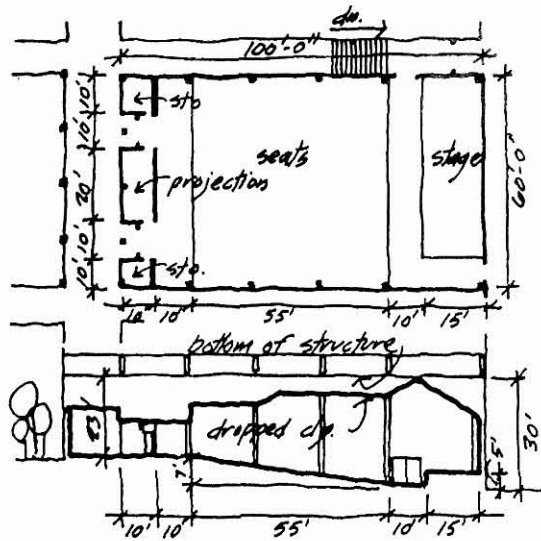

3. Size

a. Dimensions of the boundaries of our space (in plan and section).

b. Dimensions of any permanent easements (door swings, circulation ways that must remain due to access to other spaces, etc.).

c. Area in square feet available for our project in the space after all unusable space has been subtracted.

d. Any potential dimensional changes in the space due to projects other than our own.

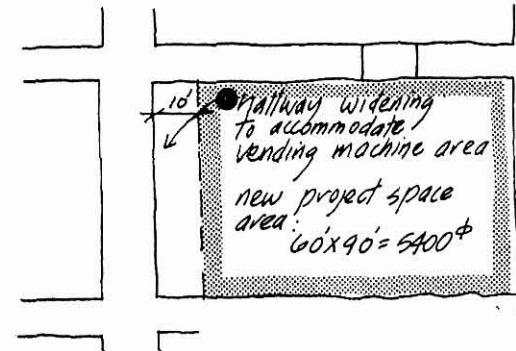
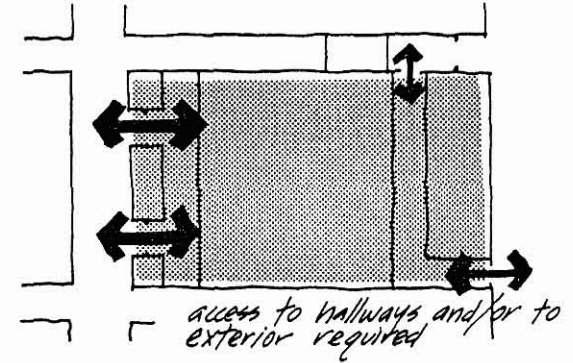



GOVERNED BY UNIFORM BUILDING CODE

1. Activity - Offices/Clerical (Within classroom building.)
2. Occupancy - Group F Projected occupancy in the space is 40 people
3. Exits - Minimum is 2 required exits for occupancy over 30 people. Maximum distance to exit is 150 ft. Maximum length of dead end corridor is 20 ft. Maximum riser height is 7 1/2 in. Minimum tread is 10 in.
4. Ventilation - Windows and skylights must amount to 1/8 of the total floor area, 1/2 of which must be operable. (1/8 of 5400 sf. = 675 sf.)  
or... use artificial light and mechanical ventilation system. (2 changes of air per hour.)
5. Fire rating: 1 Hour rating required for exterior walls.
6. Maximum occupancy - 5400 sf / 100 sf. per person = 54 people.
7. Toilets - Requirements met by existing toilets in the building.

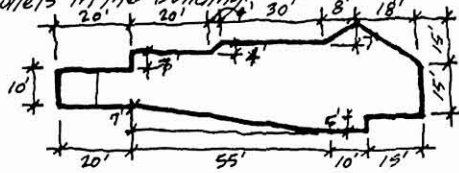

NONE

4. Legal
  - a. Exits, ventilation, fire protection, occupancy limits, toilet facilities, and other restrictions dictated by codes or regulatory agencies.

- b. Handicapped requirements.

1. Wheelchair dimensions - 3'-0" h. x 2'-1" w x 5'-8" l.
2. Circulation space - 4'-8" minimum width.
3. Ramps - 1 in 12 maximum slope.

5. Significant Physical Features in the Space
  - a. Steps or slopes in the floor and ceiling.

- b. Columns.

- c. Floor drains.

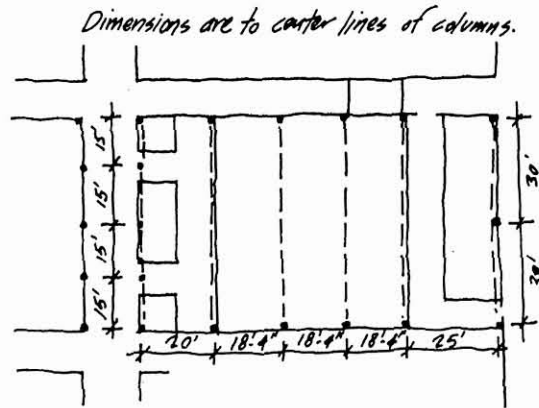

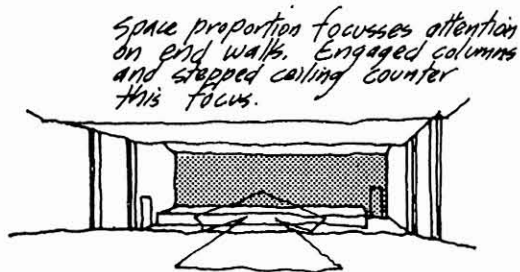
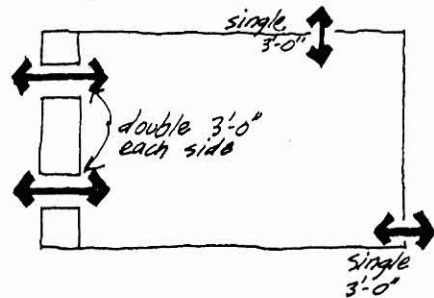
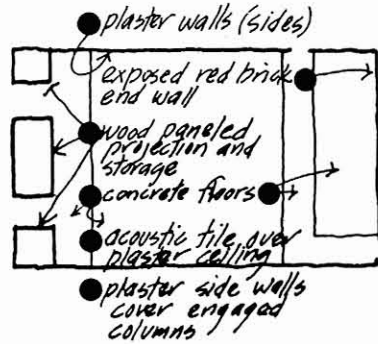

d. Existing materials (floor, walls, and ceiling).

e. Lighting (type, control and placement).

f. Doors into and out of the space.

g. Windows and skylights.

h. Surface patterns, geometries, axes, etc.

S<sub>1</sub> Controls cans directed at stage  
 S Lighting controls at entries and lectern  
 R Rheostat controls at entries and lectern  
 □ Indicates fixtures on rheostatic controls  
 All lights in auditorium are recessed incandescent.

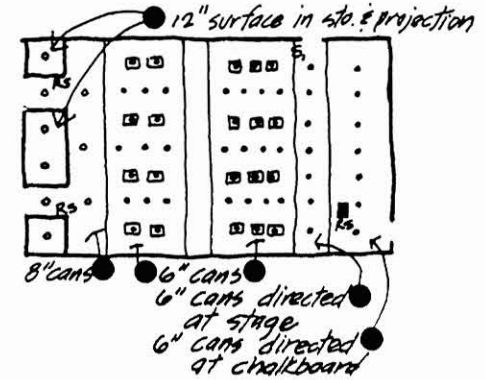

NONE

NONE

- i. Furniture or equipment that must remain in the space (fixed and movable).

- j. Color.

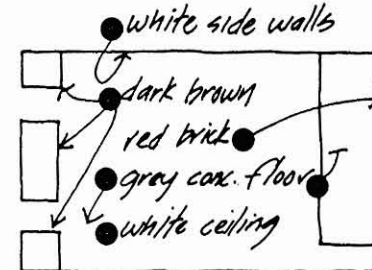

6. Circulation

- a. Major and minor pedestrian movement patterns in the vicinity of and adjacent to our project space (inside and outside).

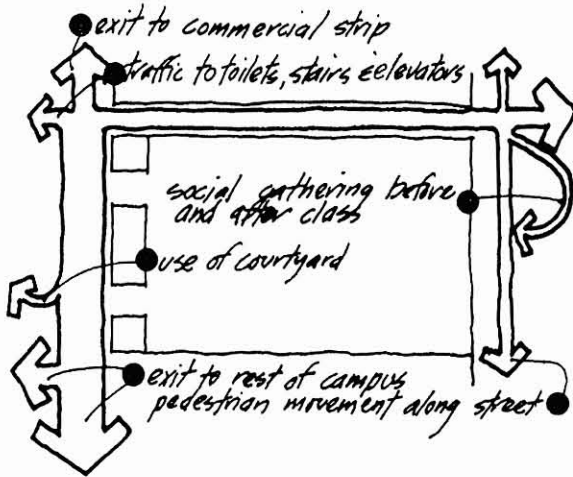

- b. Major and minor movement patterns within our space that may remain.

**NO THROUGH SPACE CIRCULATION TO BE MAINTAINED.**

- c. Routes to fire stairs and emergency escape routes.

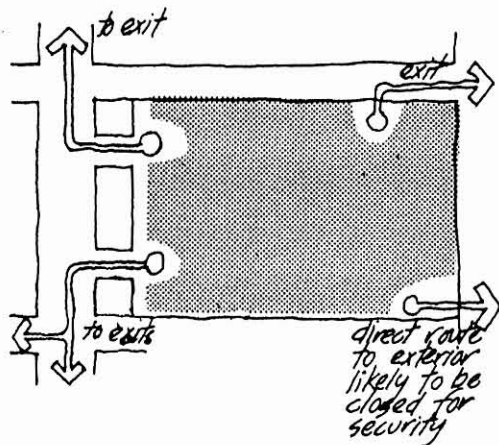

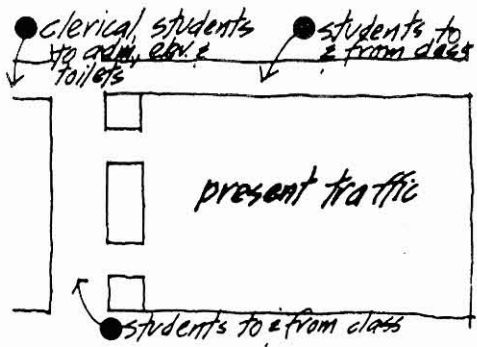

- traffic pulse in hallways primarily weekdays on the hour due to class schedule. (year round)
- up to 350 students moving through halls in a 10 min. period at class changes
- with elimination of auditorium function the traffic volume will drop to maximum of about 75 students.
- trickle of student and clerical movement between classes and on weekend.

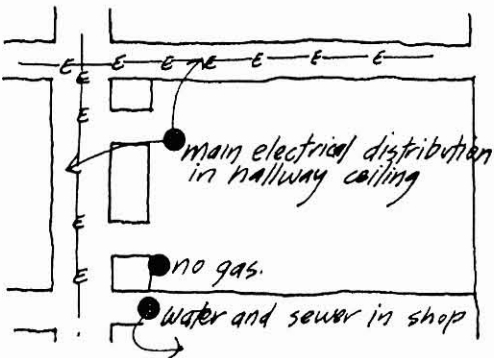

d. Types of traffic using the circulation routes (types of people, carts, etc.).

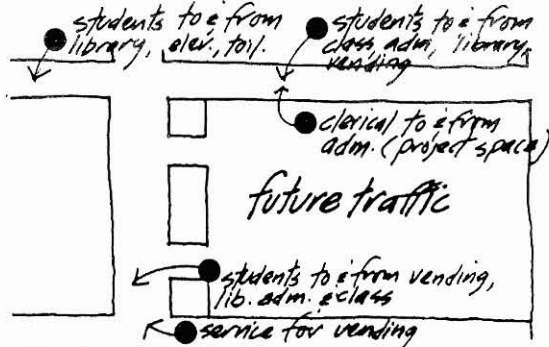

e. Access and egress points in our space in relation to circulation.

f. Schedule, intensity and duration of surrounding traffic.

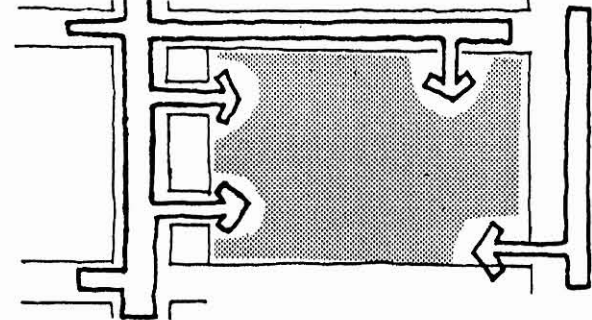

7. Technical and Utilities

a. Location and capacity of electrical, telephone, sewer, gas and water.

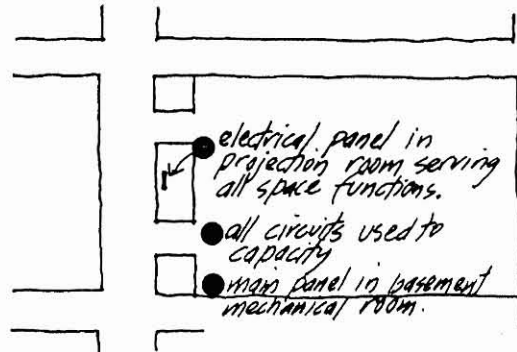

b. Routes of the various utility systems within the building and within and adjacent to our space.

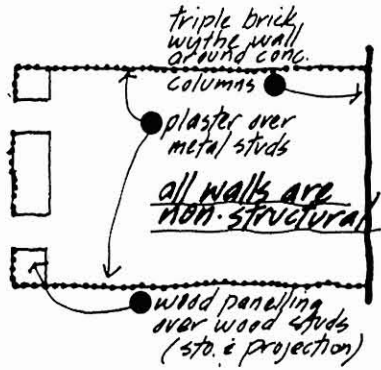

c. Permanent walls and removable walls.

d. Structural capacity of the floor. **NOT AN ISSUE / FLOOR ON GRADE**

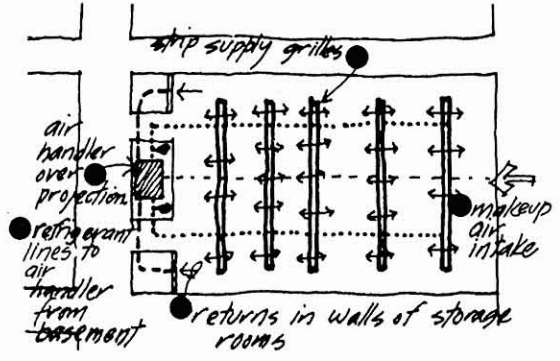

e. Routes of all ductwork and location of all supply and return grills.

f. Utility situation above any dropped ceilings in our space. **NOTHING BUT DUCTWORK**

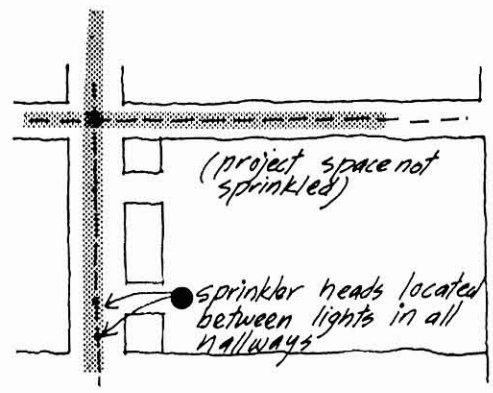

g. Fire sprinkler system routes and head locations. Fire, heat and smoke alarms.

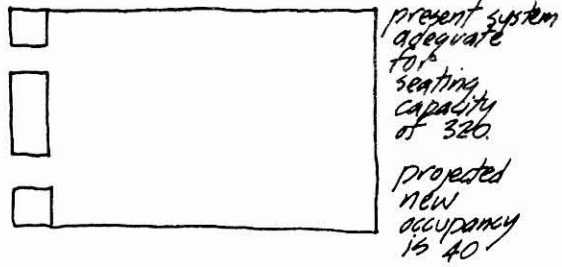

- h. Capacity of the ventilation and heating and cooling system to deliver what is required for the new space use.

8. Sensory

- a. Interior and exterior views from the space.

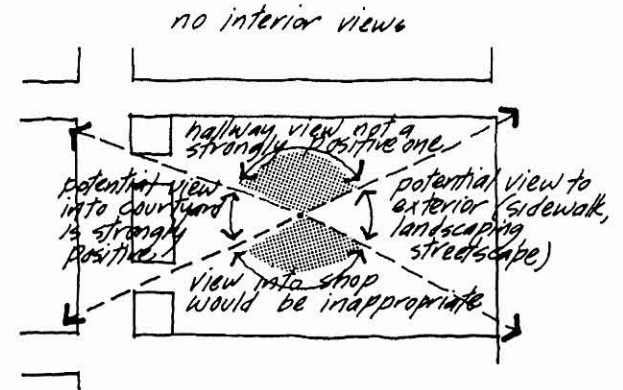

- b. Views from neighboring spaces through our space.

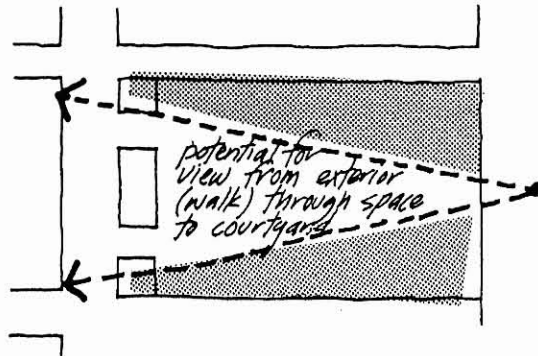

- c. Views into our space from adjacent spaces, circulation or outside the building.

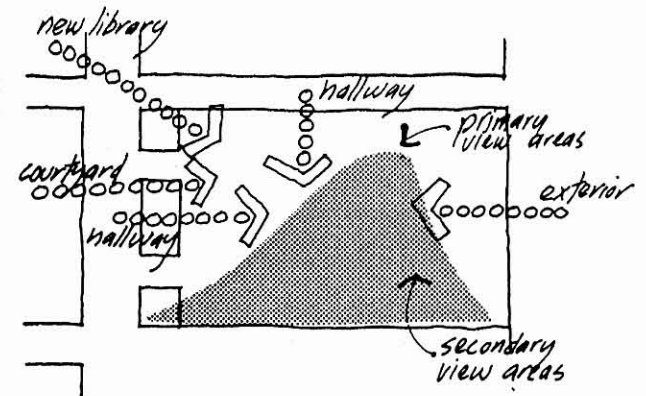

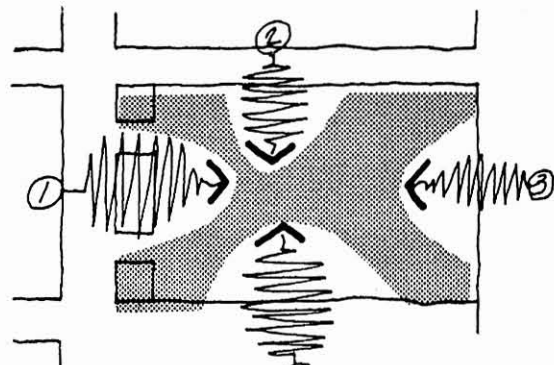
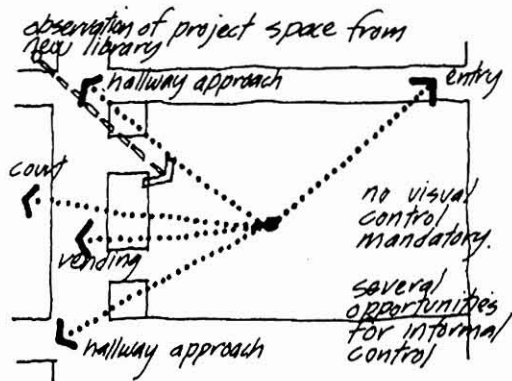

- ① loud conversation at class changes
- ② on the hour 8 AM - 5 PM M-F.  
60-70 dB. (at source)  
noise from vending machines when they are installed from ①
- ③ street noise constant at 60-70 dB (at source)
- ④ noise from shop machinery intermittent 70-80 dB (at source)

d. Required visual control into our space from adjacent spaces or from our space to other spaces.

e. Extent to which various views into or out of our space are assets or liabilities (bad views, privacy problems, etc.).

f. Locations, generators, schedules and intensities of any significant noises in the vicinity of our space (interior or exterior sounds).

g. Locations, generators, schedules and intensities of any odor problems in the vicinity of our space (interior or exterior sources).

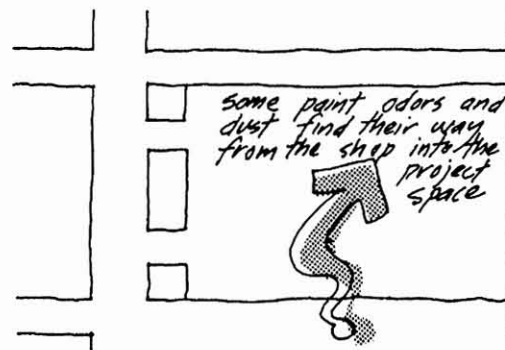
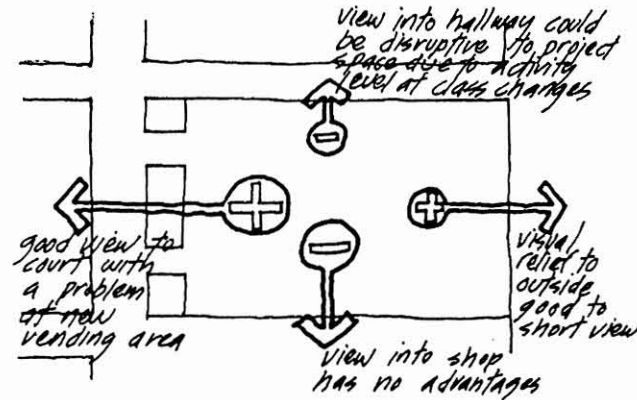

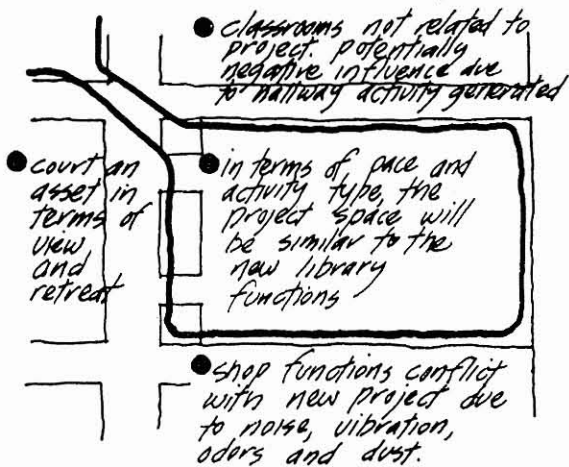
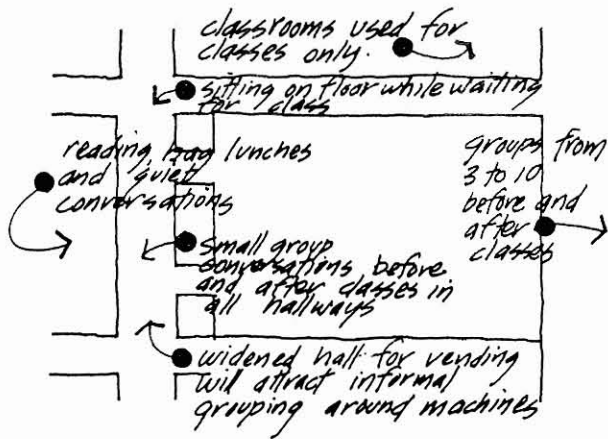

9. Human

- a. Existing behavioral and sociological aspects of surrounding spatial uses including circulation.

- b. Characteristics of the principal users of surrounding spaces such as population, density, schedule, age, ethnic patterns and expectations.

- c. Existing activities that will remain in our space, or in adjacent spaces that could be beneficial or detrimental to the functions which will be housed in our space or that we might contribute to or jeopardize.

- d. Potential problems in the building such as vandalism and criminal activities.

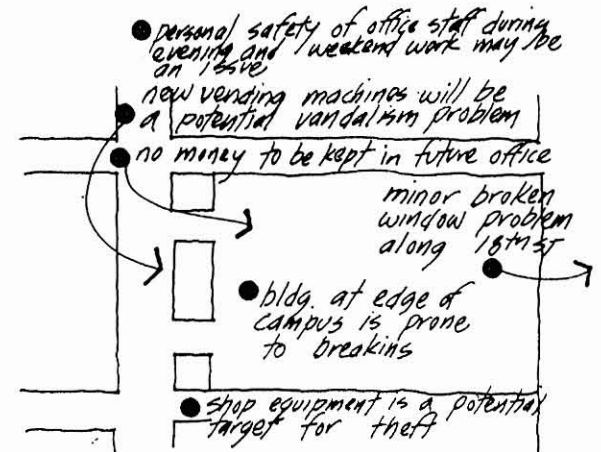
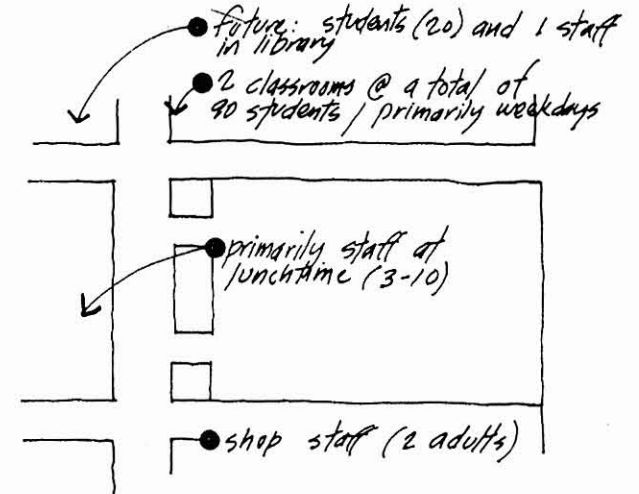



- University administration sets thermostats at 68°F in the winter and 80°F in summer. Normally, no deviation from these standards is permitted.
- Heating season is Oct-Mar. Cooling season is Mar-Sept.
- Building is opened on a 24-hour basis with security patrols at regular intervals in the evening and on weekends (year round).
- Campus lighting standards: 15fc in hallways and non-occupied spaces. 30fc general illumination in occupied spaces with provision for additional task lighting.
- no user manipulation of thermostats allowed by the university administration

- e. Posture and policy of the management of the building with respect to energy consumption, security and hours of operation.

## 10. Climate

- a. Placement of thermostats in the space in relation to zones of heating and cooling.

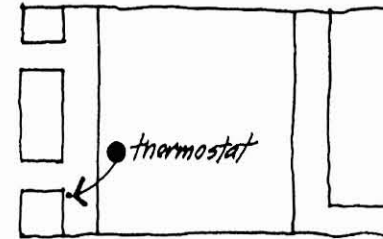

- b. Extent to which occupants of our space can set their own thermostats or whether this is done for the whole building by the management.

- c. If temperature is set by management, document the heating and cooling settings.

68°F winter  
80°F summer

- d. Yearly climatic variation for the exterior in terms of temperature, rainfall, snowfall, humidity, wind and sun path. See page 103.

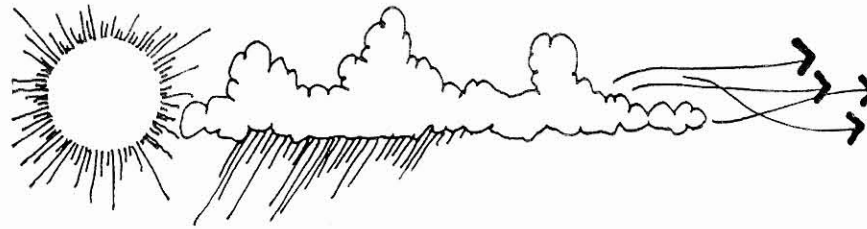

- e. Extent of direct sun penetration into our space through windows and skylights.

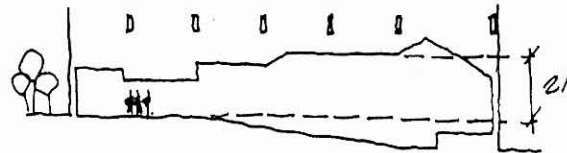
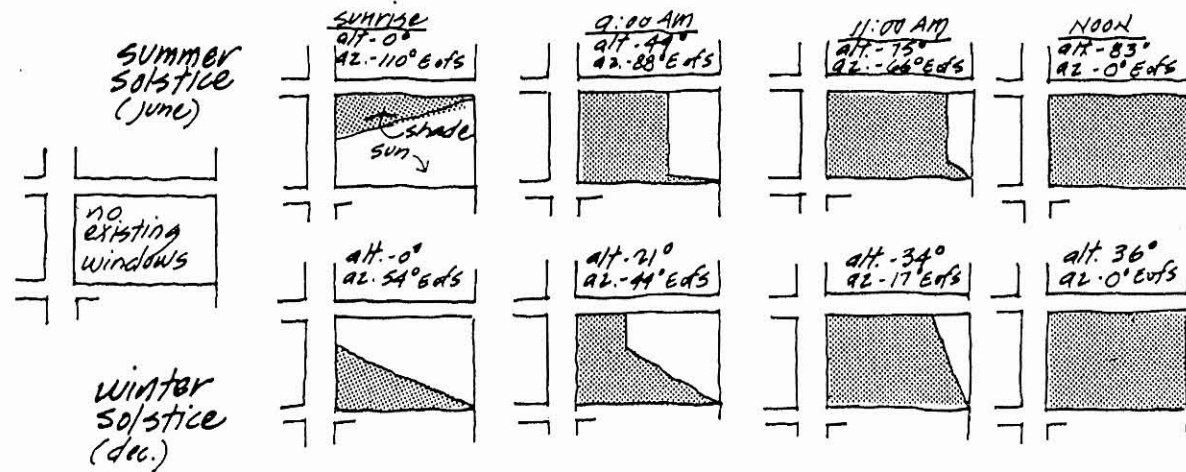

sun/shadow patterns are based on assumption of 21' high opening across entire width of the space

As in the contextual analysis of an exterior site, the checklist should be considered a starting point. Depending on the particular project, some of the issues will drop out as irrelevant and others, that do not appear here, will be added.

We will need to decide which of the issues are vital form givers to our eventual layout of the interior space and be sure to analyze those concerns in depth. The discussion earlier regarding the making of the diagrams applies to an interior analysis as well.

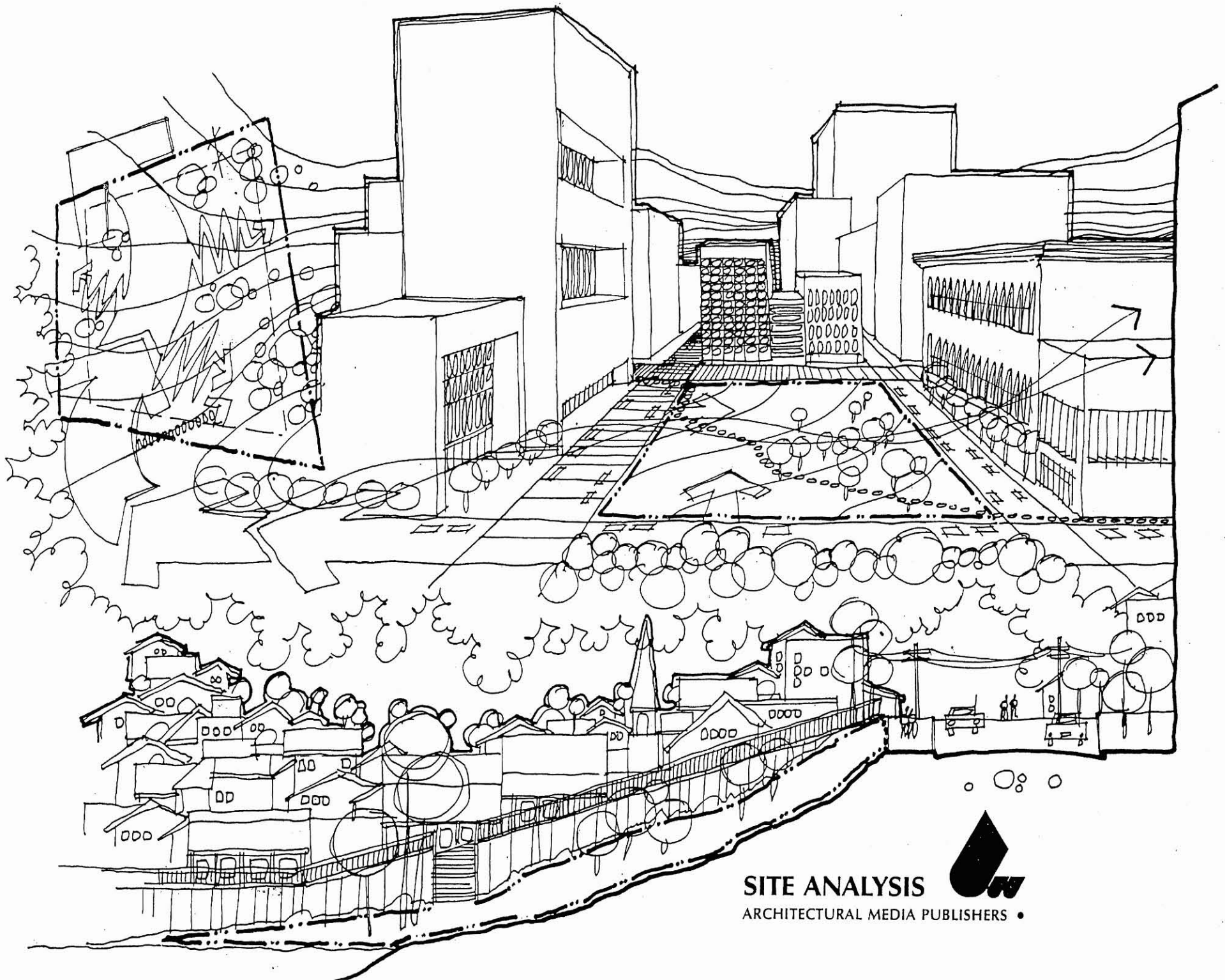

**SITE ANALYSIS**

ARCHITECTURAL MEDIA PUBLISHERS •

